

Notes: -

1. The legend is from the Transport Heavy alphabet at the 'x'-heights shown.
2. The outlines of the tiles do not form part of the sign.
3. The colours are as follows: -  
 Border, panel dividers, legend, arrows and central reserve symbol ——— Black  
 Blocks (shaded) ——— Red  
 Background ——— Yellow
4. Details of the width restriction roundel are given on P 629.
5. The illumination of the sign must accord with the requirements of the current 'Traffic Signs Regulations and General Directions'.
6. The order of languages may be reversed if required.
7. All dimensions are given in millimetres.
8. Any of the elements shown in diagrams 7280 to 7288 inclusive may be used in the main centre panel. Design spaces for those elements and other design rules relating to the layout of blocks and arrows are given in chapter 7 of the Traffic Signs Manual.

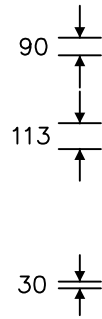

**STAY IN LANE**  
**CADWCH**  
**AT EICH LÔN**

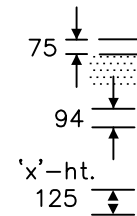
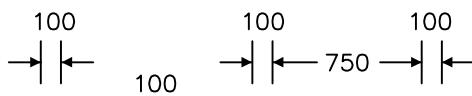
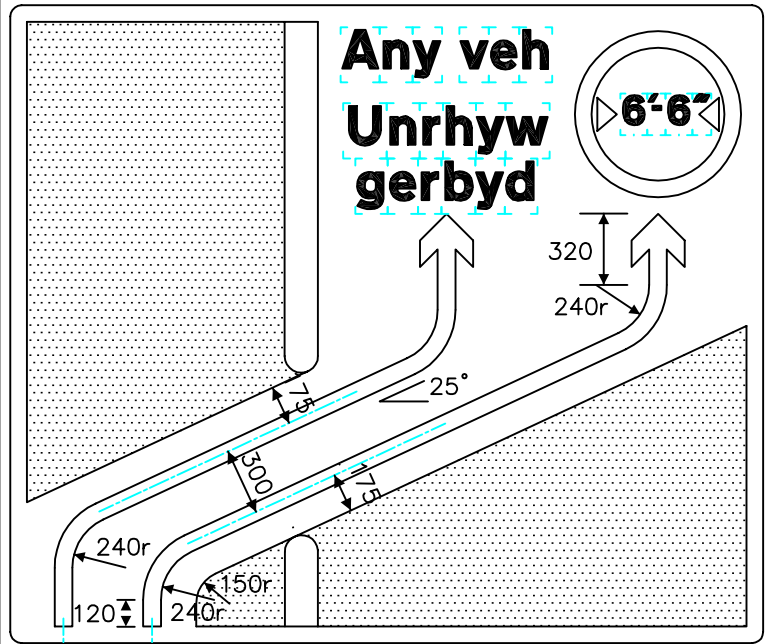
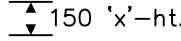

**Any veh**  
**Unrhyw**  
**gerbyd**

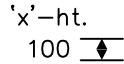
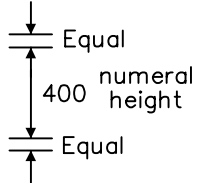
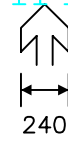

**Max speed**  
**Cyflymder uchaf** **30**

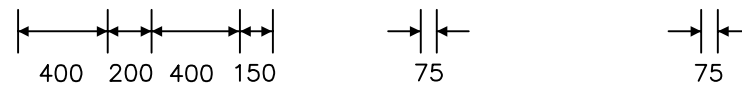

REVISIONS	
1.	Redrawn & notes amended 28.9.00
2.	Bottom panel legend amended 23.4.03
3.	Notes amended 20.12.06
Before using this drawing, confirm with RNM3 Division that it has not been superseded.	
Drn. A.T.I.	Appd.
Chkd.	Appl. date 29.11.96
Issue: 20.12.06	
Scale: Photo-reduced	
Title Temporary Sign	
LANE CHANGES ACROSS CENTRAL RESERVE (with HGV's prohibited in right hand lane)	
WELSH ASSEMBLY GOVERNMENT	
Drwg. no.	WAG/P 7210