

Notes: -

1. The legend 'taxi' ('tacsi') is from the Transport Medium alphabet at the 'x'-heights shown.
2. Symbol details are given on drawings 23 (motor cycle) S 24 (cycle) and WAG/S 25 (bus). The symbols must always face left.
3. The outlines of the tiles and centre lines of bars do not form part of the sign.
4. The colours are as follows: -
Legend, symbols _____ White
and border _____
Background _____ Blue
5. The 'x'-heights shown are given in millimetres, all other dimensions are given in stroke widths (i.e. 1s/w = 1/4 'x'-height).
6. The order of languages may be reversed if required.
7. Variants: - The legend 'taxi' ('tacsi') may be omitted. The legend 'local/lleol' may be omitted. If it is omitted, the bus symbol will have all its windows.
8. A time plate may be added at the base of the sign in the same colours (see drawing WAG/P 961).

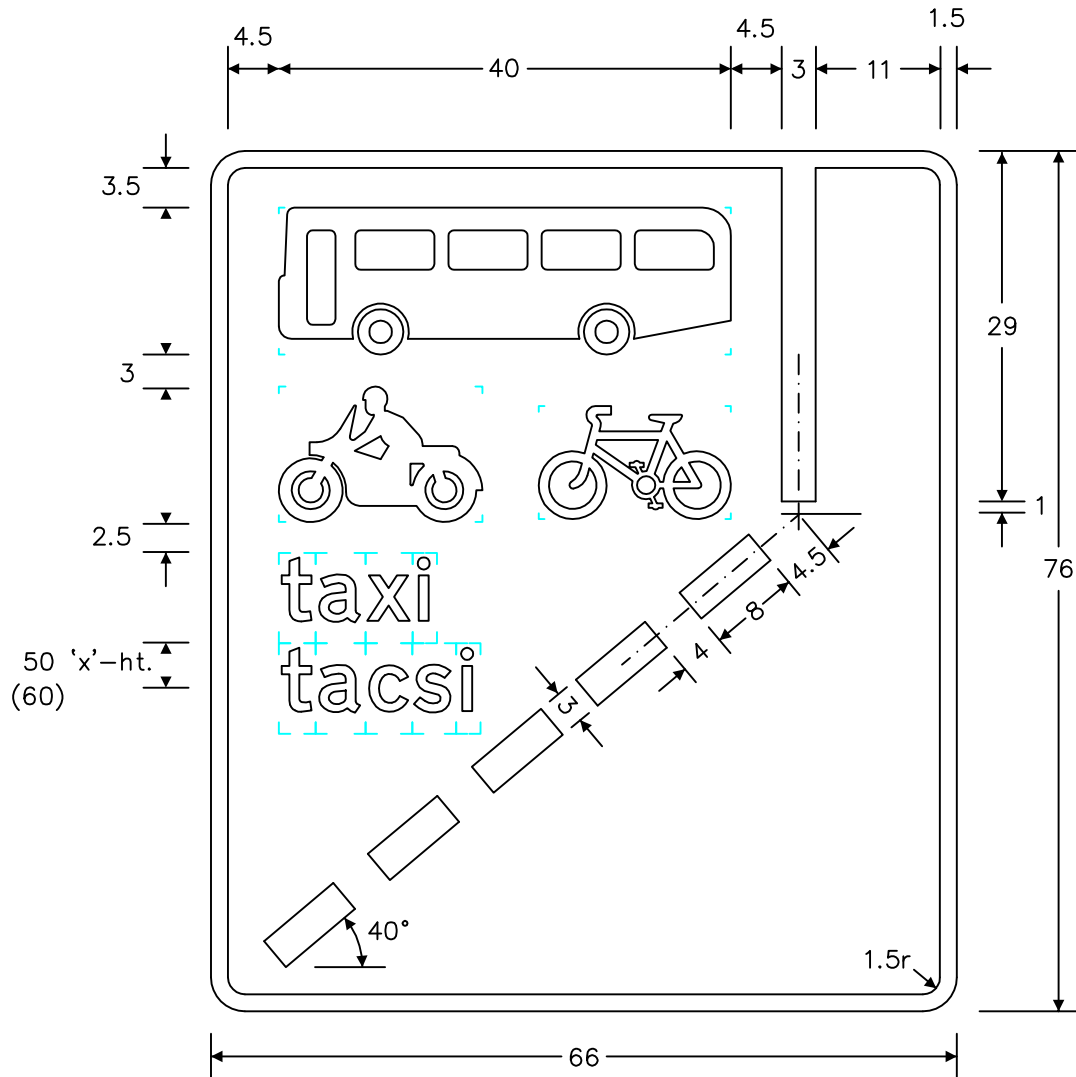

Variant for bus symbol

The legend 'local/lleol' is in Transport Heavy alphabet coloured black

SYMBOL	Width (sw)	Height (sw)
Bus WAG/S 25	40	13
Motor cycle S23	18	12
Pedal cycle S 24	17	10

REVISIONS

Before using this drawing, confirm with RNM3 Division that it has not been superseded.

Drn. G.A.T. Appd.

Chkd. Appl. date 9.2.12

Issue: 30.3.12

Scale: Photo-reduced

Title
Bus & Cycle Sign
BUS AND SOLO
MOTOR CYCLE
LANE AHEAD

WELSH GOVERNMENT

Drwg. no.
WAG/P 958A