

Notes: -

- The legends are from the Transport Heavy and Transport Medium alphabets at the 'x'-heights shown.
- Details of the bicycle symbol are given on S 24.
- The outlines of the tiles do not form part of the sign.
- The colours are as follows: -

Main Sign: -  
 Background \_\_\_\_\_ Green  
 Border, panel divider & arrows \_\_\_\_\_ White  
 Route numbers \_\_\_\_\_ Yellow (Transport Medium)

Non-primary route panel: -  
 Legend \_\_\_\_\_ Black (Transport Heavy)  
 Background \_\_\_\_\_ White

Cycle route panel: -  
 Legend \_\_\_\_\_ White (Transport Medium)  
 Background \_\_\_\_\_ Blue

Route number patch: -  
 Number \_\_\_\_\_ White (Transport Medium)  
 Background: -  
 National Cycle Route \_\_\_\_\_ Red  
 Regional Cycle Route \_\_\_\_\_ Blue

- The illumination of the sign must accord with the requirements of the current 'Traffic Signs Regulations and General Directions'.
- The 'x'-heights shown are given in millimetres, all other dimensions are given in stroke widths (i.e. 1s/w = 1/4'x'-height).
- The order of languages may be reversed if required.

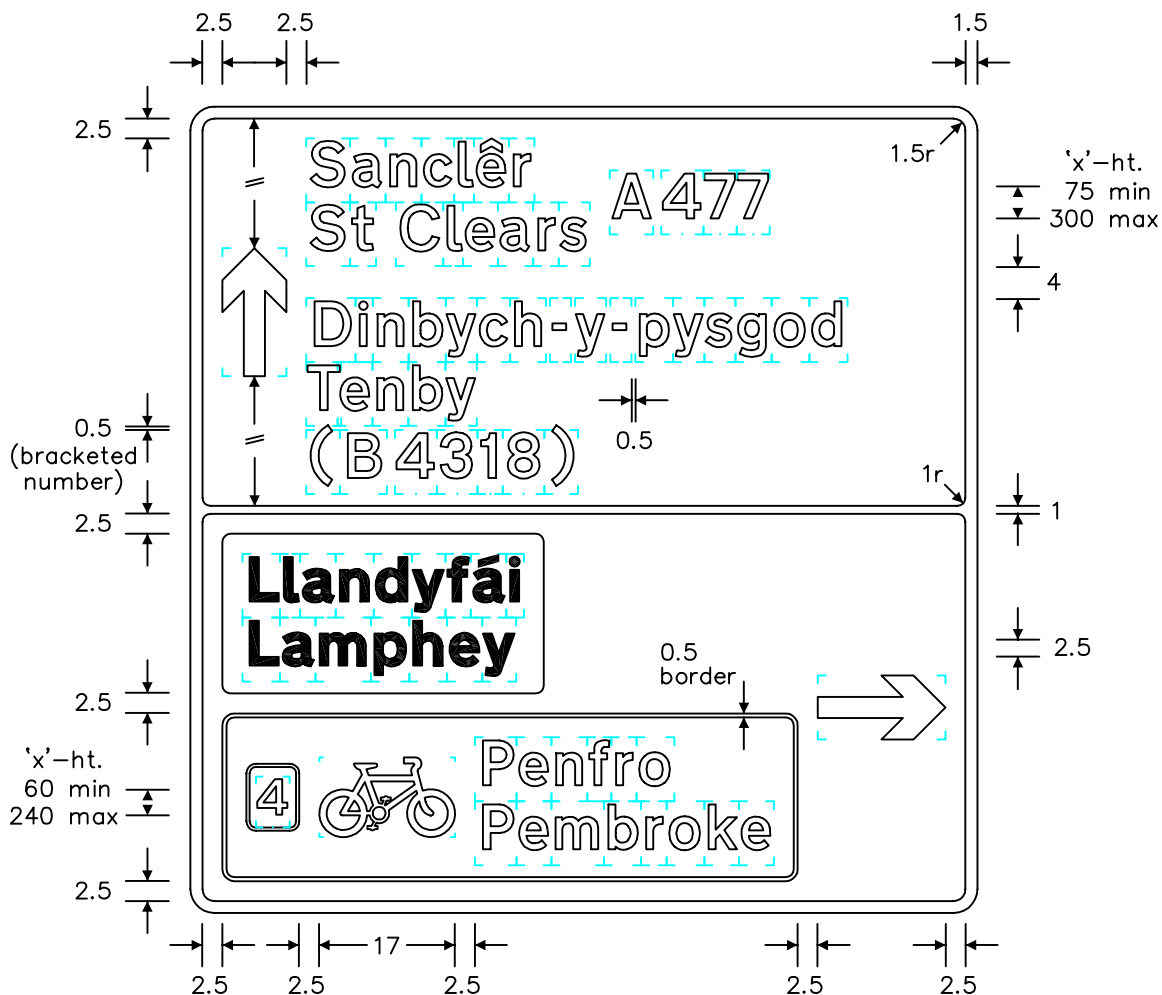

REVISIONS	
1. Notes amended	4.4.07
Before using this drawing, confirm with RNM3 Division that it has not been superseded.	
Drn. A.T.I.	Appd.
Chkd.	Appl. date 2.1.04
Issue: 4.4.07	
Scale: Photo-reduced	
Title Primary Route Directional Sign (Stack-type)	
JUNCTION AHEAD OF A PRIMARY ROUTE WITH A NON-PRIMARY ROUTE WHICH IS AN ALTERNATIVE NUMBERED ROUTE FOR PEDAL CYCLES FORMING PART OF A CYCLE ROUTE NETWORK	
WELSH ASSEMBLY GOVERNMENT	
Drwg. no. WAG/P 2005.1	