

Notes:—

- The legend is from the Transport Medium alphabet.
- Details of the cycle and pedestrian symbols are given on dwg. nos. S24 & S2.
- The outlines of the tiles do not form part of the sign.
- The colours are as follows:—
 Background of main sign ————— Blue
 Legend, symbols, arrow & borders ————— White
 Background to route number patches:
 National route ————— Red
 Regional route ————— Blue
- All dimensions are in stroke widths based on a main sign 'x'-height of 30mm min and 60mm max. (4sw = 'x'-height)
 The 'x'-height of the route number is 24mm min and 48mm max (ie 80% of the main sign 'x'-height).
- The sign is designed in accordance with the current design rules.
- The order of languages may be reversed if required.
- See sheet 2 for further details of advance direction signs. See sheet 3 for details of the route number patch.

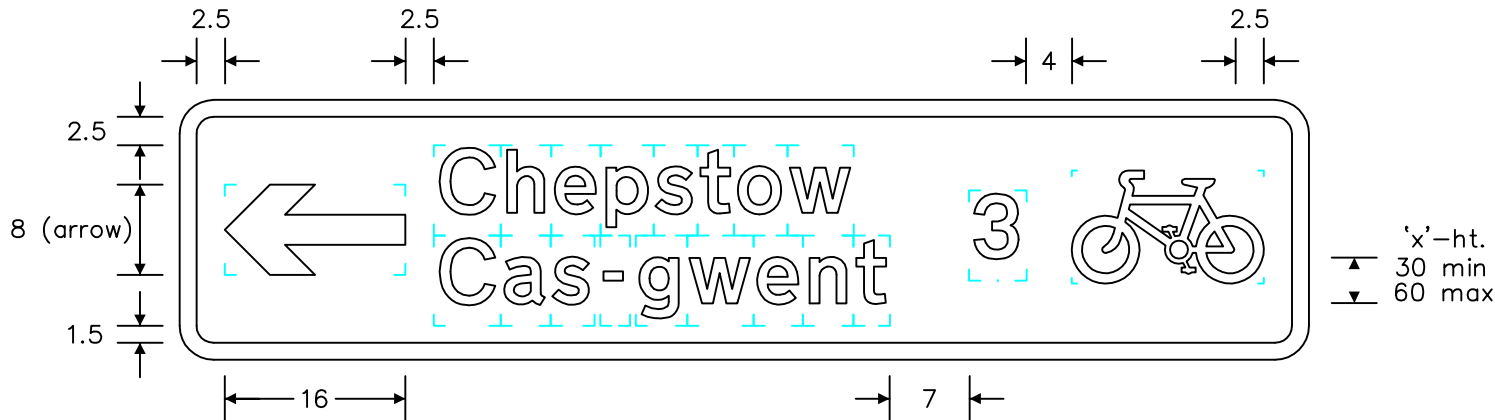
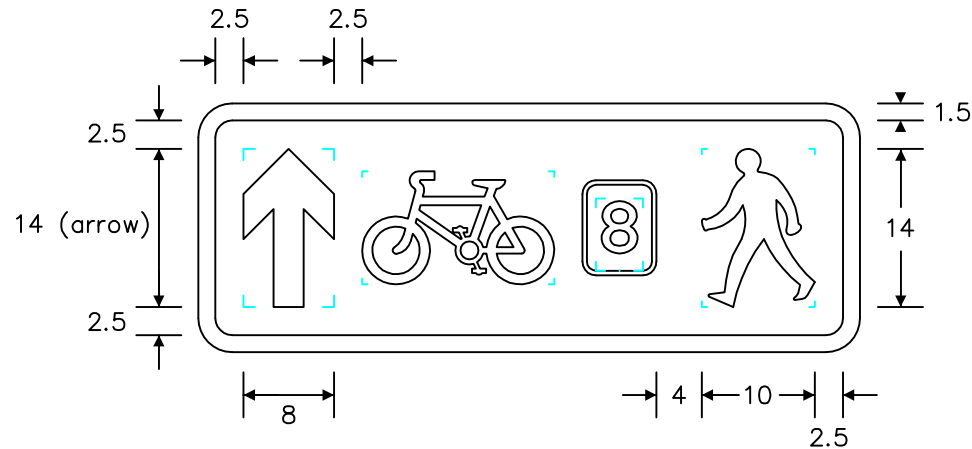
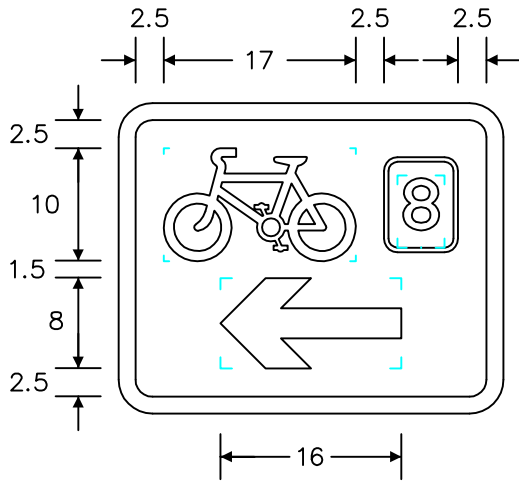
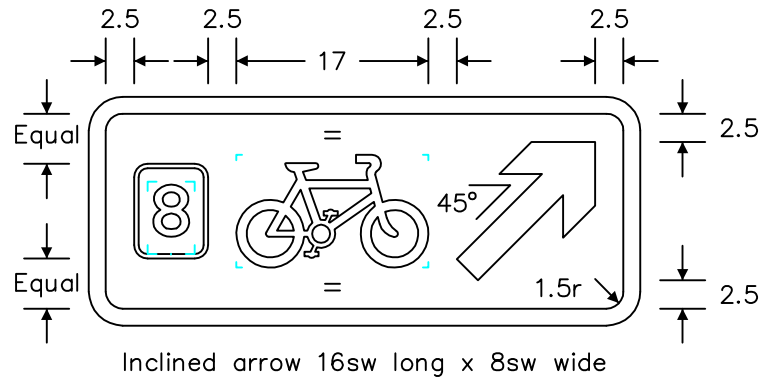

REVISIONS	
1.	Nos. changed from 732.4 & 732.5 1.9.97
2.	Redrawn & notes amended 23.8.00
3.	No. changed from 2601 23.8.04
4.	Variants added 22.6.06
5.	Sheet 4 added with new variants 13.2.12
<small>Before using this drawing, confirm with RNM3 Division that it has not been superseded.</small>	
Drn. A.T.I.	Appd.
Chkd.	Appl. date 12.11.81
Issue: 30.3.12	
Scale: Photo-reduced	
Title Cycle Route Signs	
DIRECTION OF CYCLE ROUTE AT JUNCTION AHEAD	
WELSH GOVERNMENT	
Drwg. no. WAG/P 2601.1	
Sheet 1 of 4	

Notes:-

1. The legend is from the Transport Medium alphabet at the 'x'-heights shown.
2. Details of the cycle and pedestrian symbols are given on dwg. nos. S24 & S2.
3. The outlines of the tiles do not form part of the sign.
4. The colours are as follows:-
 Background of main sign _____ Blue
 Legend, symbols, arrow & borders _____ White
 Background to route number patches:
 National route _____ Red
 Regional route _____ Blue
5. The 'x'-heights shown are given in millimetres, all other dimensions are given in stroke widths based on the 'x'-ht. of the destination.
 (i.e. 1s/w = 1/4'x'-height)
6. The sign is designed in accordance with the current design rules.
7. The order of languages may be reversed if required.
8. See sheet 1 for other dimensions and sheet 3 for details of the route number patch.

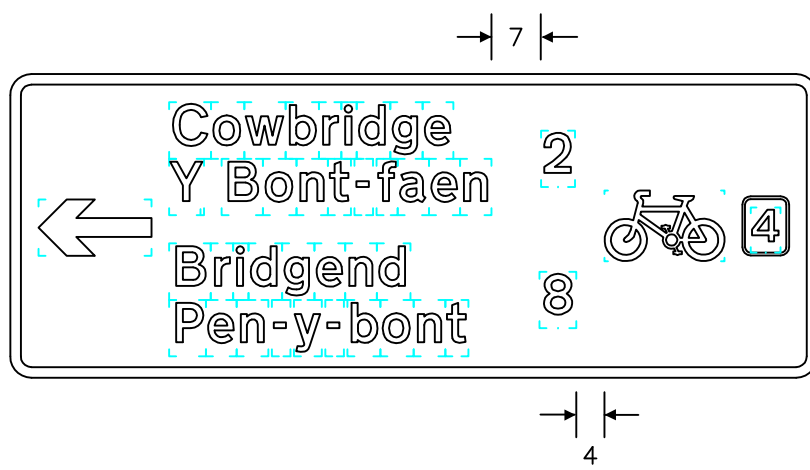
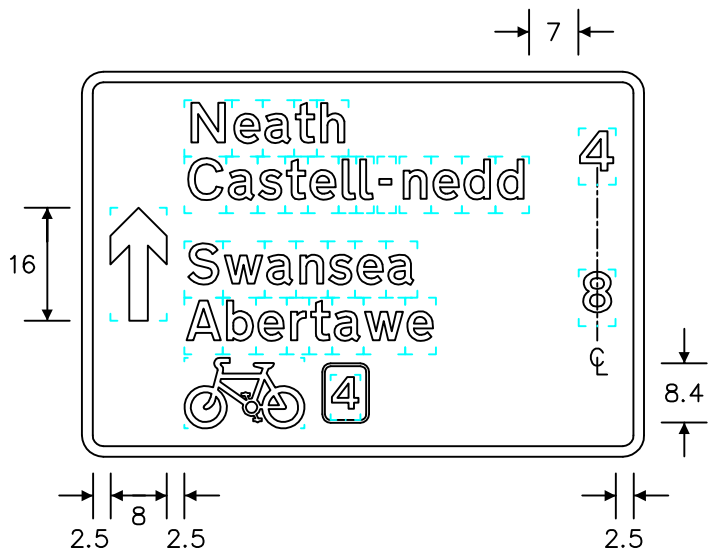
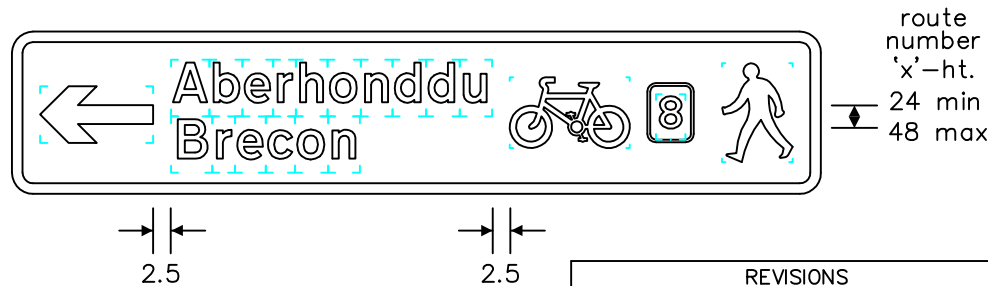
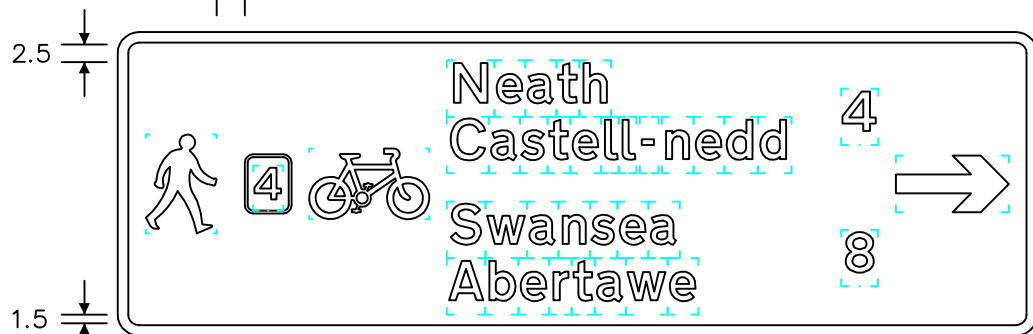
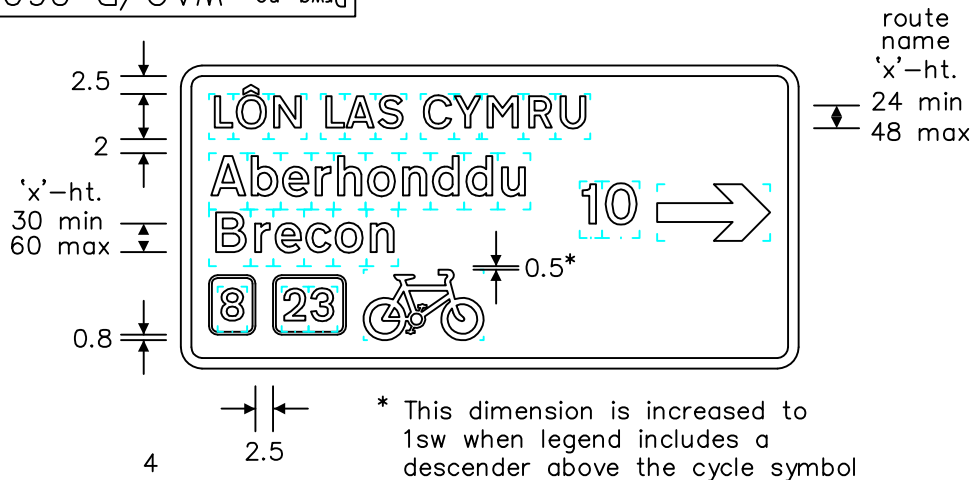

REVISIONS	
1.	Nos. changed from 732.4 & 732.5 1.9.97
2.	Redrawn & notes amended 23.8.00
3.	No. changed from 2601 23.8.04
4.	Variants added 22.6.06
5.	Sheet 4 added with new variants 13.2.12
Before using this drawing, confirm with RNM3 Division that it has not been superseded.	
Drn. A.T.I.	Appd.
Chkd.	Appl. date 12.11.81
Issue: 30.3.12	
Scale: Photo-reduced	
Title Cycle Route Signs DIRECTION OF CYCLE ROUTE AT JUNCTION AHEAD	
WELSH GOVERNMENT	
Drwg. no.	WAG/P 2601.1
Sheet 2 of 4	

Notes:-

- Numerals and brackets are from the Transport Medium alphabet.
- The outlines of the tiles do not form part of the route number patches.
- The colours are as follows:-
 Numerals, brackets & borders _____ White
 Background to route number patches:
 National route _____ Red
 Regional route _____ Blue
- Unbracketed dimensions are in stroke widths based on the 'x'-height of the main sign. Bracketed dimensions are in stroke widths based on the 'x'-height of the cycle route number which is 80% of the main 'x'-height. See sheet 1 for 'x'-heights. (4sw = 'x'-height)
- See sheets 1 and 2 for details of advance direction signs with destinations, cycle route names and distances.

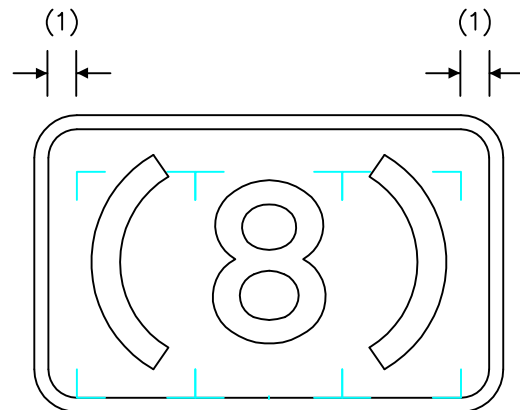
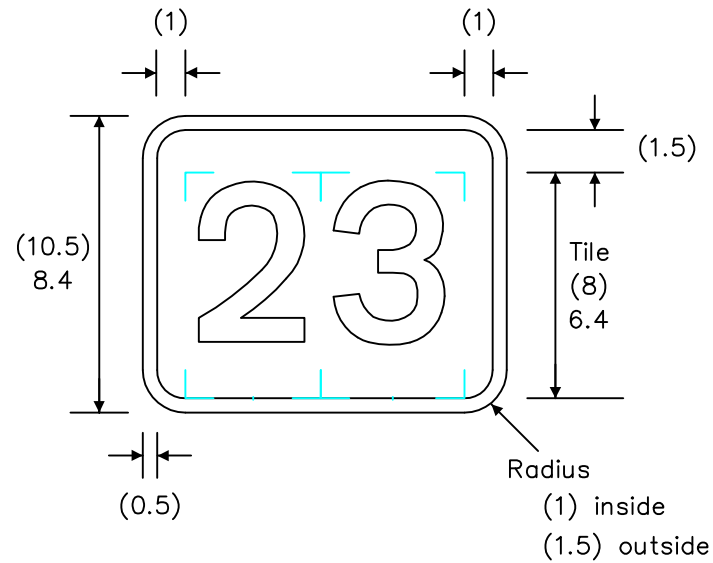

REVISIONS	
1.	Nos. changed from 732.4 & 732.5 1.9.97
2.	Redrawn & notes amended 23.8.00
3.	No. changed from 2601 23.8.04
4.	Variants added 22.6.06
5.	Sheet 4 added with new variants 13.2.12
Before using this drawing, confirm with RNM3 Division that it has not been superseded.	
Drn. A.T.I.	Appd.
Chkd.	Appl. date 12.11.81
Issue: 30.3.12	
Scale: Photo-reduced	
Title	Cycle Route Signs
DIRECTION OF CYCLE ROUTE AT JUNCTION AHEAD (Cycle Route No.)	
WELSH GOVERNMENT	
Drwg. no.	WAG/P 2601.1
Sheet 3 of 4	

- Notes:-
1. The legend is from the Transport Medium alphabet at the 'x'-heights shown.
 2. Details of the cycle and pedestrian symbols are given on dwg. nos. S24 & S2.
 3. The outlines of the tiles do not form part of the sign.
 4. The colours are as follows:-
 Background of main sign _____ Blue
 Legend, symbols, arrow & borders _____ White
 Background to route number patches:
 National route _____ Red
 Regional route _____ Blue
 5. The 'x'-heights shown are given in millimetres, all other dimensions are given in stroke widths based on the 'x'-ht. of the destination.
 (i.e. $1s/w = 1/4 \times \text{'x'-height}$)
 6. The sign is designed in accordance with the current design rules.
 7. The order of languages may be reversed if required.
 8. See sheet 1 for other dimensions and sheet 3 for details of the route number patch.

* This dimension is increased to 1sw when legend includes a descender above the cycle symbol

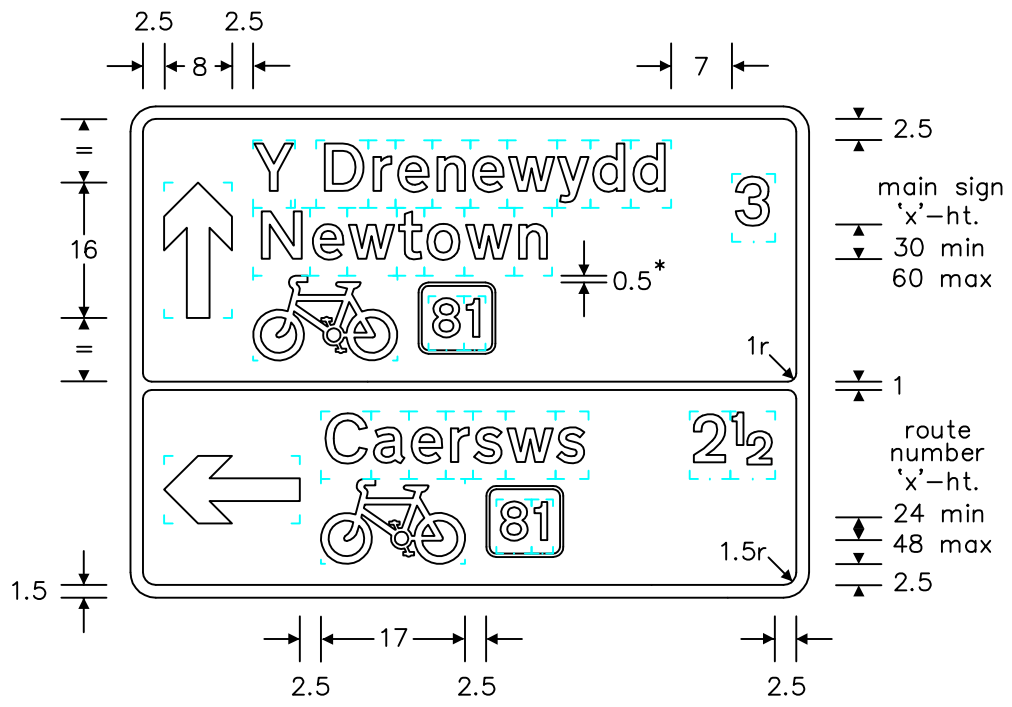

REVISIONS	
1.	Nos. changed from 732.4 & 732.5 1.9.97
2.	Redrawn & notes amended 23.8.00
3.	No. changed from 2601 23.8.04
4.	Variants added 22.6.06
5.	Sheet 4 added with new variants 13.2.12
Before using this drawing, confirm with RNM3 Division that it has not been superseded.	
Drn. A.T.I.	Appd.
Chkd.	Appl. date 12.11.81
Issue: 30.3.12	
Scale: Photo-reduced	
Title	Cycle Route Signs
DIRECTION OF CYCLE ROUTE AT JUNCTION AHEAD	
WELSH GOVERNMENT	
Drwg. no.	WAG/P 2601.1
Sheet 4 of 4	