



Llywodraeth Cymru  
Welsh Government

The Building Regulations 2010

# Approved Document

**Volume 2 – Buildings other than  
dwellinghouses**

# B

**Fire safety**

2006 Edition incorporating 2010, 2013, 2016, 2017 and  
2020 amendments - For use in Wales\*

## Main changes

This Approved Document supports the requirements of Part B of Schedule 1 to the Building Regulations 2010.

The 2020 amendments to the Approved Document incorporate the following changes:

i. Amendments to Appendix A (Performance of materials, products and structures). The Approved Document has been amended to strengthen the provisions for assessments in lieu of fire tests. The requirements take effect on 31 December 2020 . Approved Document B Volume 2: 2006 edition incorporating 2010, 2013 and 2016 amendments will continue to apply to work started before 31 December 2020, or to work subject to a building notice, full plans application or initial notice submitted before 31 December 2020.

ii. The incorporation of the content of the amendment slip made in circular **WGC 003/2020** in relation to the ban of combustible materials in the external wall of buildings. This includes the definition of an external wall:

<https://gov.wales/sites/default/files/publications/2020-01/building-regulations-wales-circular-wgc-003-2020.pdf>.

The changes made within the circular **WGC 003/2020** came into force on the 13 January 2020.

iii. The incorporation of the content of the amendment slip made in circular **WG 011/2017** in relation to Table's 10 and 11. Table 10 (Classification of linings) has been changed in relation to wallcoverings which conform to BSEN 15102:2007 Decorative wallcoverings – roll and panel form products.

Table 11 (Limitations applied to thermoplastic rooflights and lighting diffusers in suspended ceilings and Class 3 plastic rooflights) has been changed to incorporate more flexible guidance for small diffusers and rooflights.:

<https://gov.wales/sites/default/files/publications/2019-06/amendments-to-building-regulations-approved-documents-a-b-volume-2-and-c-wg-0112017.pdf>

The changes made within the circular **WGC 011/2017** came into force on the 1 September 2017.

This approved document gives guidance for compliance with the Building Regulations for building work carried out in Wales.

# Contents

---

	Page
<b>Use of guidance</b>	<b>1</b>
The Approved Documents	1
Limitation on requirements	3
Materials and workmanship	3
Interaction with other legislation	4
<b>General introduction</b>	<b>7</b>
Scope	7
Arrangement of sections	7
Management of premises	9
Property protection	10
Independent schemes of certification and accreditation	11
Inclusive design	11
Material alteration	12
Alternative approaches	12
<b>B1 Means of warning and escape – The Requirement</b>	<b>17</b>
<b>B1 Guidance</b>	<b>18</b>
Performance	18
Introduction	18
<b>B1 Section 1: Fire alarm and fire detection systems</b>	<b>22</b>
Introduction	22
Flats	22
Buildings other than flats	23
<b>B1 Section 2: Automatic Fire Suppression Systems</b>	<b>30</b>
Introduction	31
General	31
Installation	32
Alternative Designs for residential means of escape	33
Material alterations	33
<b>B1 Section 3: Means of escape from flats</b>	<b>34</b>
Introduction	34
General provisions	34
Provisions for escape from flats where the floor is not more than 4.5m above ground level	37
Provisions for flats with a floor more than 4.5m above ground level	37
Means of escape in the common parts of flats	42
Common stairs	48
Live/work units	51

## Contents

<b>B1 Section 4: Design for horizontal escape in buildings other than flats</b>	<b>52</b>
Introduction	52
Escape route design	52
Small premises	64
Residential care homes	67
<b>B1 Section 5: Design for vertical escape</b>	<b>70</b>
Introduction	70
Number of escape stairs	70
Provision of refuges	71
Width of escape stairs	74
Calculation of minimum stair width	74
Protection of escape stairs	81
Basement stairs	85
External escape stairs	85
<b>B1 Section 6: General provisions</b>	<b>87</b>
Introduction	87
Protection of escape routes	87
Doors on escape routes	88
Stairs	89
General	93
Lifts	95
Mechanical ventilation and air-conditioning systems	96
Refuse chutes and storage	97
Shop storerooms	98
<b>B2 Internal fire spread (linings) – The Requirement</b>	<b>99</b>
<b>B2 Guidance</b>	<b>100</b>
Performance	100
Introduction	100
<b>B2 Section 7: Wall and ceiling linings</b>	<b>103</b>
Classification of linings	103
Variations and special provisions	104
Thermoplastic materials	105
<b>B3 Internal fire spread (structure) – The Requirement</b>	<b>110</b>
<b>B3 Guidance</b>	<b>111</b>
Performance	111
Introduction	111

## Contents

<b>B3 Section 8: Loadbearing elements of structure</b>	<b>113</b>
Introduction	113
Fire resistance standard	113
Raised storage areas	114
Conversion to flats	115
<b>B3 Section 9: Compartmentation</b>	<b>116</b>
Introduction	116
Provision of compartmentation	117
Construction of compartment walls and compartment floors	121
Openings in compartmentation	123
Protected shafts	124
<b>B3 Section 10: Concealed spaces (cavities)</b>	<b>130</b>
Introduction	130
Provision of cavity barriers	130
Pathways around fire separating elements	132
Extensive cavities	133
Construction and fixings for cavity barriers	137
<b>B3 Section 11: Protection of openings and fire-stopping</b>	<b>139</b>
Introduction	139
Openings for pipes	139
Ventilation ducts, flues, etc.	141
Fire-stopping	142
<b>B3 Section 12: Special provisions for car parks and shopping complexes</b>	<b>145</b>
Introduction	145
Car parks	145
Shopping complexes	147
<b>B4 External fire spread – The Requirement</b>	<b>148</b>
<b>B4 Guidance</b>	<b>150</b>
Performance	150
Introduction	150
<b>B4 Section 13: Construction of external walls</b>	<b>151</b>
Introduction	151
Fire resistance standard	151
Portal frames	151
Combustibility of external walls	152
External surfaces	152

## Contents

<b>B4 Section 14: Space separation</b>	<b>157</b>
Introduction	157
Boundaries	158
Unprotected areas and fire resistance	161
Methods for calculating acceptable unprotected area	164
<b>B4 Section 15: Roof coverings</b>	<b>168</b>
Introduction	168
Classification of performance	168
Separation distances	168
<b>B5 Access and facilities for the Fire and Rescue Service –</b>	
<b>The Requirement</b>	<b>173</b>
<b>B5 Guidance</b>	<b>174</b>
Performance	174
Introduction	174
<b>B5 Section 16: Fire Mains and hydrants</b>	<b>176</b>
Introduction	176
Provision of fire mains	176
Number and location of fire mains	176
Design and construction of fire mains	176
Provision of private hydrants	176
<b>B5 Section 17: Vehicle access</b>	<b>178</b>
Introduction	178
Buildings not fitted with fire mains	178
Buildings fitted with fire mains	183
Design of access routes and hard standings	183
<b>B5 Section 18: Access to buildings for firefighting personnel</b>	<b>185</b>
Introduction	185
Provision of firefighting shafts	185
Number and location of firefighting shafts	186
Design and construction of firefighting shafts	186
Rolling shutters in compartment walls	188
<b>B5 Section 19: Venting of heat and smoke from basements</b>	<b>189</b>
Introduction	189
Provision of smoke outlets	189
Construction of outlet ducts or shafts	192
Basement car parks	192

## Contents

### Appendices

<b>Appendix A: Performance of materials, products and structures</b>	<b>193</b>
Introduction	193
Fire resistance	194
Roofs	196
Reaction to fire	197
Non-combustible materials	197
Materials of limited combustibility	198
Internal linings	198
Thermoplastic materials	199
Fire test methods	201
<b>Appendix B: Fire doors</b>	<b>217</b>
<b>Appendix C: Methods of measurement</b>	<b>223</b>
<b>Appendix D: Purpose of groups</b>	<b>228</b>
<b>Appendix E: Definitions</b>	<b>231</b>
<b>Appendix F: Fire behavior of insulating core panels used for internal structures</b>	<b>240</b>
<b>Appendix G: Fire safety information</b>	<b>244</b>
<b>Appendix H: Maintenance of automatic fire suppression systems</b>	<b>246</b>
<b>Appendix I: Standards and other publications referred to</b>	<b>247</b>

### Diagrams

#### B1

1. Gallery floors with no alternative exit	36
2. Flat where all habitable rooms have direct access to an entrance hall	38
3. Flat with restricted travel distance from furthest point to entrance	38
4. Flat with an alternative exit, but where all habitable rooms have no direct access to an entrance hall	40
5. Multi-storey flat with alternative exits from each habitable room, except at entrance level	40
6. Multi-storey flat with protected entrance hall and landing	41
7. Flats served by one common stair	43
8. Flats served by more than one common stair	44
9. Common escape route in small single stair building	45
10. Travel distance in dead-end condition	53
11. Alternative escape routes	56
12. Inner room and access room	57
13. Exits in a central core	58
14. Open connections	58
15. Merging flows at final exit	60
16. Subdivision of corridors	62
17. Dead-end corridors	64

## Contents

18.	Maximum travel distances in a small two or three storey premises with a single protected stairway to each storey	65
19.	Progressive horizontal evacuation in care homes	68
20.	Refuge formed by compartmentation	72
21.	Refuge formed in a stairway	73
22.	Maximum travel distance in a two-storey premises with a single open stair	83
23.	Maximum travel distance in a small three-storey premises with a single stair to each storey	83
24.	External protection to protected stairways	91
25.	Fire resistance of areas adjacent to external stairs	92

## B2

26.	Lighting diffuser in relation to ceiling	106
27.	Layout restrictions on Class 3 plastic rooflights, TP(b) rooflights and TP(b) lighting diffusers	108
27A.	Layout restrictions on small Class 3 or D-s3,d2 plastic rooflights, TP(b) Rooflights and lighting diffusers	109

## B3

28.	Compartment floors: illustration of guidance in paragraph 9.18.	119
29.	Compartment walls and compartment floors with reference to relevant paragraphs in Section 9	122
30.	Junction of compartment wall with roof	125
31.	Protected shafts	127
32.	Uninsulated glazed screen separating protected shaft from lobby or corridor	128
33.	Provisions for cavity barriers	131
34.	Cavity walls excluded from provisions for cavity barriers	135
35.	Fire-resisting ceiling below concealed space	135
36.	Provisions for cavity barriers in double-skinned insulated roof sheeting	136
37.	Pipes penetrating structure	140
38.	Enclosure for drainage or water supply pipes	143
39.	Flues penetrating compartment walls or floors	144

## B4

40.	Provisions for external surfaces of walls	154
41.	Relevant boundary	158
42.	Notional boundary	160
43.	Status of combustible surface material as unprotected area	161
44.	Unprotected areas which may be disregarded in assessing the separation distance from the boundary	163
45.	The effect of a canopy on separation distance	163
46.	Permitted unprotected areas in small residential buildings	166
47.	Limitations on spacing and size of plastic rooflights having a Class 3 (National class) or Class D-s3, d2 (European class) or TP(b) lower surface	169



## Contents

### B5

48.	Example of building footprint and perimeter	180
49.	Relationship between building and hard-standing/access roads for high reach fire appliances	181
50.	Turning facilities	184
51.	Provision of firefighting shafts	187
52.	Components of a firefighting shaft	188
53.	Fire-resisting construction for smoke outlet shafts	190

### Appendices

C1.	Measurement of door width	225
C2.	Cubic capacity	225
C3.	Area	225
C4.	Height of building	226
C5.	Number of storeys	226
C6.	Height of top storey in building	227
C7.	Free area of smoke ventilators	227
E1.	Recessed car parking areas	239

### Tables

#### B1

1.	Limitations on distance of travel in common areas of block of flats	46
2.	Limitations on travel distance	54
3.	Minimum number of escape routes and exits from a room, tier or storey	55
4.	Widths of escape routes and exits	59
5.	Maximum distances of travel in small premises with a protected stair	66
6.	Minimum width of escape stairs	75
7.	Capacity of a stair for basements and for simultaneous evacuation of the building	76
8.	Minimum width of stairs design for phased evacuation	80
9.	Provisions for escape lighting	95

#### B2

10.	Classification of linings	103
11.	Limitations applied to thermoplastic rooflights and lighting diffusers in suspended ceilings and Class 3 plastic rooflights	107

#### B3

12.	Maximum dimensions of building or compartment (non-residential buildings)	120
13.	Maximum dimensions of cavities in non-domestic buildings (Purpose Groups 2-7)	134
14.	Maximum nominal internal diameter of pipes passing through a compartment wall/floor	140

## Contents

### B4

15.	Permitted unprotected areas in small buildings or compartments	167
16.	Limitations on roof coverings	170
17.	Class 3 (National class) or Class D-s3,d2 plastic rooflights: limitations on use and boundary distance	171
18.	TP(a) and TP(b) plastic rooflights: limitations on use and boundary distance	172

### B5

19.	Fire and rescue service vehicle access to buildings (excluding blocks of flats) not fitted with fire mains	179
20.	Typical fire and rescue service vehicle access route specification	182

## Appendices

A1.	Specific provisions of test for fire resistance of elements of structure etc.	202
A2.	Minimum periods of fire resistance	206
A3.	Limitations on fire-protecting suspended ceilings	209
A4.	Limitations on the use of uninsulated glazed elements on escape routes	210
A5.	Notional designations of roof coverings	211
A6.	Use and definitions of non-combustible materials	213
A7.	Use and definitions of materials of limited combustibility	214
A8.	Typical performance ratings of some generic materials and products	215
B1.	Provisions for fire doors	220
C1.	Floor space factors	223
D1.	Classification of purpose groups	229

# Use of guidance

---

## What is an Approved Document?

This Approved Document, which takes effect on 31 December 2020, has been approved and issued by Welsh Ministers for the purpose of providing practical guidance with respect to the requirements of Schedule 1 to and Regulations 7 and 37A of the Building Regulations 2010 (SI 2010/2214) for Wales.

At the back of this document is a list of all the documents that have been approved and issued by the Welsh Ministers for this purpose.

The intention of issuing Approved Documents is to provide guidance about compliance with specific aspects of the Building Regulations in some of the more common building situations. They include examples of what, in ordinary circumstances, may be reasonable provision for compliance with the relevant requirement(s) of the Building Regulations to which they refer.

If guidance in an Approved Document is followed there will be a presumption of compliance with the requirement(s) covered by the guidance. However, this presumption is not conclusive, so simply following guidance does not guarantee compliance in an individual case. It is also important to note that there may well be other ways of achieving compliance with the requirements. Thus unless required by regulation here is therefore no obligation to adopt any particular solution contained in this Approved Document if you would prefer to meet the relevant requirement in some other way. However, persons intending to carry out building work should always check with their Building Control Body (BCB), either the local authority or an Approved Inspector that their proposals comply with Building regulations.

The guidance contained in this Approved Document relates only to the particular requirements of the Building Regulations that the document addresses (see 'Requirements' below). However, building work may be subject to more than one requirement of the Building Regulations. In such cases the work will also have to comply with any other applicable requirements of the Building Regulations.

## How to use this Approved Document

In this document the following conventions have been adopted to assist understanding and interpretation:

- (a) Texts shown against a blue background are extracts from the Building Regulations or Building (Approved Inspectors etc.) Regulations, and set out the legal requirements of Building Regulations. It should be remembered however that, as noted above, building works must comply with all the other applicable provisions of Building Regulations.

## Use of guidance

- (b) Details of technical publications referred to in the text of this document. A reference to a publication is likely to be made for one of two main reasons. The publication may contain additional or more comprehensive technical detail, which it would be impractical to include in full in this Document but which is needed to fully explain ways of meeting the requirements; or it is a source of more general information. The reference will be to a specified edition of the document. The Approved Document may be amended from time to time to include new references or to refer to revised editions where this aids compliance.
- (c) When this approved document refers to a named standard or other document, the relevant version is listed in Appendix B. However, if the issuing body has revised or updated the listed version of the standard or document, you may use the new version as guidance if it continues to address the relevant requirements of the Building Regulations.

## Where you can get further help

If you do not understand the technical guidance or other information set out in this Approved Document and the additional detailed technical references to which it directs you, there are a number of routes through which you can seek further assistance:

- The Welsh Government website: [www.gov.wales](http://www.gov.wales)
- The Planning Portal website: [https://www.planningportal.co.uk/wales\\_en/info/7/building\\_control](https://www.planningportal.co.uk/wales_en/info/7/building_control)
- If you are the person undertaking the building work you can seek assistance either from your local authority building control service or from your approved inspector (depending on which building control service you are using, or intend to use, to certify compliance of your work with the requirements of the Building Regulations).
- Businesses registered with a competent person self-certification scheme may be able to get technical advice from their scheme operator.
- If your query is of a highly technical nature you may wish to seek the advice of a specialist, or industry technical body, in the area of concern.

## Responsibility for compliance

It is important to remember that if you are the person (e.g. designer, builder, installer) carrying out building work to which any requirement of Building Regulations applies you have a responsibility to ensure that the work complies with any such requirement. The building owner may also have a responsibility for ensuring compliance with Building Regulation requirements and could be served with an enforcement notice in cases of non-compliance.

## Use of guidance

### Other requirements

The guidance contained in an Approved Document relates only to the particular requirements of the Regulations which that document addresses. The building work will also have to comply with the Requirements of any other relevant paragraphs in Schedule 1 to the Regulations.

There are Approved Documents which give guidance on each of the other requirements in Schedule 1 and on Regulation 7.

### Limitation on requirements

In accordance with Regulation 8, the requirements in Parts A to D, F to K, N and P (except for paragraphs H2 and J7) of Schedule 1 to the Building Regulations do not require anything to be done except for the purpose of securing reasonable standards of health and safety for persons in or about buildings (and any others who may be affected by buildings or matters connected with buildings). This is one of the categories of purpose for which Building Regulations may be made.

Paragraphs H2 and J7 are excluded from Regulation 8 because they deal directly with prevention of the contamination of water. Parts E and M (which deal, respectively, with resistance to the passage of sound, and access to and use of buildings) are excluded from Regulation 8 because they address the welfare and convenience of building users. Part L is excluded from Regulation 8 because it addresses the conservation of fuel and power. All these matters are amongst the purposes other than health and safety, that may be addressed by Building Regulations.

### Requirement for residential automatic fire suppression systems

This Approved Document provides guidance on compliance with the requirements for premises described in 37A of the Building Regulations to be provided with an automatic fire suppression system.

### Materials and workmanship

Any building work which is subject to the requirements imposed by Schedule 1 to the Building Regulations shall be carried out in accordance with Regulation 7. Guidance on meeting these requirements on materials and workmanship is contained in Approved Document 7.

Building Regulations are made for specific purposes, primarily the health and safety, welfare and convenience of people and for energy conservation. Standards and other technical specifications may provide relevant guidance to the extent that they relate to these considerations. However, they may also address other aspects of performance or matters which, although they relate to health and safety etc., are not covered by the Building Regulations.

When an Approved Document makes reference to a named standard, the relevant version of the standard to which it refers is the one listed at the end of the publication. However, if this version has been revised or updated by the

## Use of guidance

issuing standards body, the new version may be used as a source of guidance provided it continues to address the relevant requirements of the Regulations.

## Interaction with other legislation:

### The Regulatory Reform (Fire Safety) Order 2005

The Fire Safety Order reforms the law relating to fire safety in non-domestic premises. Specifically it replaces the Fire Precautions (Workplace) Regulations 1997 and the Fire Precautions Act 1971. It imposes a general duty to take such fire precautions as may be reasonably required to ensure that premises are safe for the occupants and those in the immediate vicinity.

By virtue of the Order, the responsible person is required to carry out a fire risk assessment of their premises. This must be a suitable and sufficient assessment of the risks to which relevant persons are exposed for the purpose of identifying the general fire precautions they need to take to comply with the requirements under the Order.

Although these requirements are applicable to premises whilst in operation, it would be useful for the designers of a building to carry out a preliminary fire risk assessment as part of the design process. If a preliminary risk assessment is produced, it can be used as part of the Building Regulations submission and can assist the fire safety enforcing authority in providing advice at an early stage as to what, if any, additional provisions may be necessary when the building is first occupied.

Article 6 of the Order does exclude some premises such as certain mines, vehicles and land forming part of an agricultural or forestry undertaking. The Order applies to all non-domestic premises, which includes the common parts of block of flats and HMOs.

Guidance on the consultation procedures that should be adopted to ensure that the requirements of all enforcing authorities are addressed at Building Regulation Approval stage is contained in *Building Regulation and Fire Safety – Procedural Guidance*, published jointly by CLG and the Welsh Assembly Government.

There may be other Statutes enforced by the local authority or the fire and rescue authority that may be applied to premises of specific uses once they are occupied.

### Houses in multiple occupation

This guidance may also be applicable to the design and construction of dwellings which are considered to be 'houses in multiple occupation' (HMOs), as defined in the Housing Act 2004, providing there are no more than six residents in any self-contained dwelling. The licensing of HMOs is typically overseen by the Local Authority who may require additional precautions over and above this guidance. Technical guidance on the assessment of hazards from fire and

## Use of guidance

preventive measures for HMOs is contained in the Housing Health and Safety Rating System Operating Guidance issued in February 2006 (ISBN: 978 1 85112 846 4).

## The Workplace (Health, Safety and Welfare) Regulations 1992

*The Workplace (Health, Safety and Welfare) Regulations 1992* contain some requirements which affect building design. The main requirements are now covered by the Building Regulations, but for further information see: *The Workplace (Health, Safety and Welfare) Regulations 1992, Approved Code of Practice and Guidance*; The Health and Safety Commission, L24; published by HMSO 1992 (ISBN: 0 11886 333 9).

*The Workplace (Health, Safety and Welfare) Regulations 1992* apply to the common parts of flats and similar buildings if people such as cleaners, wardens and caretakers are employed to work in these common parts. Where the requirements of the Building Regulations that are covered by this Part do not apply to dwellings, the provisions may still be required in the situations described above in order to satisfy the Workplace Regulations.

## The Construction (Design and Management) Regulations 2006

The purpose of this Approved Document is to provide guidance on the fire safety requirements for the completed building. It does not address the risk of fire during the construction work which is covered by the Construction (Design and Management) Regulations 2006 and the Regulatory Reform (Fire Safety) Order.

HSE has issued the following guidance on fire safety in construction: Construction Information Sheet No 51 Construction fire safety; and HSG 168 Fire safety in construction work (ISBN: 0 71761 332 1).

When the construction work is being carried out on a building which, apart from the construction site part of the building, is occupied, the Fire and Rescue Authority is responsible for the enforcement of the 2006 Regulations in respect of fire. Where the building is unoccupied, the Health and Safety Executive is responsible for enforcement on the construction site.

## Environmental Protection

Requirements under Part B of the Building Regulations and the guidance in this Approved Document are made for the purpose of ensuring the health and safety of people in and around buildings.

Natural Resources Wales<sup>1</sup> provides guidance on the design and construction of buildings in Wales for the purpose of protecting the environment. This includes Pollution Prevention Guidelines (PPG18) on *Managing Fire Water and Major Spillages*, which seeks to minimise the effects of water run-off from firefighting. It is aimed at medium to large (and small, high-risk) commercial and industrial sites and sets out requirements for the construction of containment areas for contaminated water and such other measures.

## Use of guidance

It should be noted that compliance with the Building Regulations does not depend upon compliance with other such guidance.

<sup>1</sup> Natural Resources Wales was formed in April 2013 and is a national body which replaces and incorporates the functions previously provided by the Countryside Council for Wales, the Environment Agency Wales, and the Forestry Commission Wales.



# General introduction

# B

## Fire Safety Volume 2 – Buildings other than dwellinghouses

### Scope

**0.1** Approved Document B (Fire safety) has been published in two volumes. Volume 1 deals solely with dwellinghouses (see Appendix E and Building Regulation 2(1)), while Volume 2 deals with all other types of building covered by the Building Regulations.

Where very large (over 18m in height) or unusual dwellinghouses are proposed, some of the guidance in Volume 2 may be needed to supplement that given by Volume 1.

### Arrangement of sections

**0.2** The functional requirements B1 to B5 of Schedule 1 of the Building Regulations are dealt with separately in one or more Sections. The requirement is reproduced at the start of the relevant Sections, followed by an introduction to the subject.

**0.3** The provisions set out in this document deal with different aspects of fire safety, with the following aims:

**B1:** To ensure satisfactory provision of means of giving an alarm of fire and a satisfactory standard of means of escape for persons in the event of fire in a building.

**B2:** To ensure fire spread over the internal linings of buildings is inhibited.

**B3:** To ensure the stability of buildings in the event of fire; to ensure that there is a sufficient degree of fire separation within buildings and between adjoining buildings; to provide automatic fire suppression where necessary; and to inhibit the unseen spread of fire and smoke in concealed spaces in buildings.

**B4:** To ensure external walls and roofs have adequate resistance to the spread of fire over the external envelope, and that spread of fire from one building to another is restricted.

**B5:** To ensure satisfactory access for fire appliances to buildings and the provision of facilities in buildings to assist firefighters in the saving of life of people in and around buildings.

**0.4** Whilst guidance appropriate to each of these aspects is set out separately in this document, many of the provisions are closely interlinked. For example, there is a close link between the provisions for means of escape (B1) and those for the control of fire growth (B2), fire containment and/or

## General introduction

suppression (B3) and facilities for the fire and rescue service (B5). Similarly there are links between B3 and the provisions for controlling external fire spread (B4), and between B3 and B5. Interaction between these different requirements should be recognized where variations in the standard of provision are being considered. A higher standard under one of the requirements may be of benefit in respect of one or more of the other requirements. The guidance in the document as a whole should be considered as a package aimed at achieving an acceptable standard of fire safety.

- 0.5** In the guidance on B1 the provisions for flats are separated from those for all other types of building because there are important differences in the approach that has been adopted.

## Appendices: provisions common to more than one of Part B's requirements

- 0.6** Guidance on matters that refer to more than one of the Sections is in a series of Appendices, covering the following subjects:

**Appendix A** – Performance of materials, products and structures

**Appendix B** – Fire doors

**Appendix C** – Methods of measurement

**Appendix D** – Purpose groups

**Appendix E** - Definitions

**Appendix F** – Fire behaviour of insulating core panels used for internal structures

**Appendix G** – Fire safety information

**Appendix H** – Guidance on maintenance of residential automatic fire suppression systems

**Appendix I** – Standards and other publications referred to

## Fire performance of materials, products and structures

- 0.7** Much of the guidance throughout this document is given in terms of performance in relation to standard fire test methods. Details are drawn together in Appendix A to which reference is made where appropriate. In the case of fire protection systems, reference is made to standards for systems design and installation. Standards referred to are listed in Appendix I.

## Fire doors

- 0.8** Guidance in respect of fire doors is set out in Appendix B.

## Methods of measurement

- 0.9** Some form of measurement is an integral part of much of the guidance in this document and methods are set out in Appendix C.

## General introduction

### Purpose Groups

- 0.10** Much of the guidance in this document is related to the use of the building. The use classifications are termed purpose groups and they are described in Appendix D.

### Definitions

- 0.11** The definitions are given in Appendix E.

### Fire safety information

- 0.12** Regulation 38 requires that where building work is carried out which affects fire safety, and where the building affected will be covered by the Regulatory Reform (Fire Safety) Order 2005, the person carrying out the work must provide sufficient information for persons to operate and maintain the building in reasonable safety. This information will assist the eventual owner/ occupier/employer to meet their statutory duties under the Regulatory Reform (Fire Safety) Order.

The exact amount of information and level of detail necessary will vary depending on the nature and complexity of the building's design. For small buildings, basic information on the location and nature of fire protection measures may be all that is necessary.

For larger buildings, a more detailed record of the fire safety strategy and procedures for operating and maintaining any fire protection measures of the building will be necessary. Appendix G provides advice on the sort of information that should be provided.

### Residential automatic fire suppression systems

- 0.13** Guidance on the installation and maintenance of residential **automatic fire suppression** systems can be found in Section 2 and Appendix H.

### Management of premises

- 0.14** This Approved Document has been written on the assumption that the building concerned will be properly managed.

Building Regulations do not impose any requirements on the management of a building. However, in developing an appropriate fire safety design for a building it may be necessary to consider the way in which it will be managed. A design which relies on an unrealistic or unsustainable management regime cannot be considered to have met the requirements of the Regulations.

Once the building is in use the management regime should be maintained and any variation in that regime should be the subject of a suitable risk assessment. Failure to take proper management responsibility may result in the prosecution of an employer, building owner or occupier under legislation such as the Regulatory Reform (Fire Safety) Order 2005.

## Property protection

**0.15** There are often many stakeholders, including insurers, who have a valid interest in the fire protection measures which are incorporated into a building's design. To ensure that the most effective fire protection measures are applied which are appropriate to the specific property, early consultation with the main stakeholders is essential. Failure to consult with stakeholders at an early stage could result in additional measures being required after completion, the use of the building being restricted, or insurance premiums and/or deductibles being increased.

Building Regulations are intended to ensure that a reasonable standard of life safety is provided, in case of fire. The protection of property, including the building itself, often requires additional measures and insurers will, in general, seek their own higher standards, before accepting the insurance risk.

Many insurers use the Fire Protection Association's (FPA) Design Guide for the fire protection of buildings as a basis for providing guidance to the building designer on what they require. Insurers' key objectives for achieving satisfactory standards of property protection are:

- a. to limit damage to the fabric of the building caused by heat, smoke and firefighting water.
- b. to limit damage to the contents of the building caused by heat, smoke and firefighting water.
- c. to allow the business to be trading in as short a time as possible following a fire, thus limiting business interruption.

The FPA Design Guide is a suite of publications which incorporate:

- a. An "Essential Principles" document which describes functional requirements.
- b. A range of "Design Principles" documents which provide guidance for common building situations.
- c. Separate "Core Documents" which expand upon guidance and explain construction detail which will deliver functional requirements.

Further information can be obtained from the FPA website:

<https://www.thefpa.co.uk>

Guidance on property protection issues for schools is given in Building Bulletin (BB) 100 published by DfES. This gives advice on assessing the financial and social risk of school fires and advocates the use of fire suppression or additional compartmentation where the risk is justified.

Guidance for asset protection in the Civil and Defence Estates is given in the Crown Fire Standards published by the Property Advisers to the Civil Estate (PACE).

## **Independent schemes of certification and accreditation**

**0.16** Since the performance of a system, product, component or structure is dependent upon satisfactory site installation, testing and maintenance, independent schemes of certification and accreditation of installers and maintenance firms of such will provide confidence in the appropriate standard of workmanship being provided.

Confidence that the required level of performance can be achieved will be demonstrated by the use of a system, material, product or structure which is provided under the arrangements of a product conformity certification scheme and an accreditation of installers scheme.

Third party accredited product conformity certification schemes not only provide a means of identifying materials and designs of systems, products or structures which have demonstrated that they have the requisite performance in fire, but additionally provide confidence that the systems, materials, products or structures actually supplied are provided to the same specification or design as that tested/assessed.

Third party accreditation of installers of systems, materials, products or structures provides a means of ensuring that installations have been conducted by knowledgeable contractors to appropriate standards, thereby increasing the reliability of the anticipated performance in fire. Building Control Bodies may accept the certification of products, components, materials or structures under such schemes as evidence of compliance with the relevant standard. Similarly, Building Control Bodies may accept the certification of the installation or maintenance of products, components, materials or structures under such schemes as evidence of compliance with the relevant standard. Nonetheless, a Building Control Body will wish to establish, in advance of the work, that any such scheme is adequate for the purposes of the Building Regulations.

Many certification bodies which approve such schemes are accredited by UKAS.

## **Inclusive design**

**0.17** The fire safety aspects of the Building Regulations are made for securing reasonable standards of health and safety of persons in and about buildings. This is intended to include all people, including people with disabilities.

Part M of the Regulations, *Access to and use of buildings*, requires reasonable provision for access by people to buildings. Regardless of compliance with Building Regulations, there will also be obligations under the Disability Discrimination Act 1995 for service providers and employers to consider barriers created by physical features in buildings.

## General introduction

People, regardless of disability, age or gender, should be able to gain access to buildings and use their facilities, both as visitors and as people who live or work in them.

As such the fire safety measures incorporated into a building will need to take account of the needs of all those persons who may have access to the building. It is not appropriate, except in exceptional circumstances, to presume that certain groups of people will be excluded from a building because of its use.

The provisions set out in this Approved Document are considered to be a reasonable standard for most buildings. However, there may be some people whose specific needs are not addressed. In some situations additional measures may be needed to accommodate these needs. This should be done on a case by case basis.

## Material alteration

**0.18** Under Regulation 3, the term “material alteration” is defined by reference to a list of “relevant requirements” of Schedule 1 to the Building Regulations. That list includes the requirements of Parts B1, B3, B4 and B5. This means that an alteration which, at any stage of the work, results in a building being less satisfactory than it was before in relation to compliance with the requirements of Parts B1, B3, B4 or B5 is a material alteration, and is therefore controlled by Regulation 4 as it is classed as “building work”. Regulation 4(1) requires that any building work carried out in relation to a material alteration complies with the applicable requirements of Schedule 1 and regulation 37A to the Regulations, while Regulation 4(3) requires that once that building work has been completed, the building as a whole must comply with the relevant requirements of Schedule 1 or, where it did not comply before, must be no more unsatisfactory than it was before the work was carried out.

Where an existing building is already provided with an automatic fire suppression system, the building as a whole should be no less compliant after a material alteration or building works occur. The automatic fire suppression system should be extended and re-certified to include any altered, extended and additional controlled areas.

Section 2 provides guidance on automatic fire suppression systems.

## Alternative approaches

**0.19** The fire safety requirements of the Building Regulations should be satisfied by following the relevant guidance given in this Approved Document. However, Approved Documents are intended to provide guidance for some of the more common building situations and there may well be alternative ways of achieving compliance with the requirements.

If other codes or guides are adopted, the relevant recommendations concerning fire safety in the particular publication should be followed, rather than a mixture of the publication and provisions in the relevant

## General introduction

sections of this Approved Document. However, there may be circumstances where it is necessary to use one publication to supplement another.

Guidance documents intended specifically for assessing fire safety in **existing** buildings will often include provisions which are less onerous than those set out on this Approved Document or other standards applicable to new buildings. As such, these documents are unlikely to be appropriate for use where building work, controlled by the Regulations, is proposed.

**Note:** Buildings for some particular industrial and commercial activities presenting a special fire hazard, e.g. those involved with the sale of fuels, may require additional fire precautions to those detailed in this Approved Document.

## British Standards

**0.20** Compliance with a British Standard does not of itself confer immunity from legal obligations. British Standards can, however, provide a useful source of information which could be used to supplement or provide an alternative to the guidance given in this Approved Document.

When an Approved Document makes reference to a named standard, the relevant version of the standard is the one listed at the end of the publication. However, if this version of the standard has been revised or updated by the issuing standards body, the new version may be used as a source of guidance provided it continues to address the relevant requirements of the Regulations.

Drafts for Development (DDs) are not British Standards. They are issued in the DD series of publications and are of a provisional nature. They are intended to be applied on a provisional basis so that information and experience of their practical application may be obtained and the document developed. Where the recommendations of a DD are adopted then care should be taken to ensure that the requirements of the Building Regulations are adequately met. Any observations that a user may have in relation to any aspect of a DD should be passed on to BSI.

## Health care premises

**0.21** Health care premises are quite diverse and can be used by a variety of patients, often requiring different types of care to suit their specific needs. The choice of fire safety strategy is dependent upon the way a building is designed, furnished, staffed and managed and the level of dependency of the patients.

In parts of health care premises designed to be used by patients where there are people who are bedridden or who have very restricted mobility, the principle of total evacuation of a building in the event of fire may be inappropriate. It is also unrealistic to suppose that all patients will leave without assistance. In this and other ways the specialised nature of some

## General introduction

health care premises demands a different approach to the provision of means of escape, from much of that embodied by the guidance in this Approved Document.

The Department of Health has prepared a set of guidance documents on fire precautions in health care buildings, under the general title of '*Firecode*', taking into account the particular characteristics of these buildings. These documents may also be used for non-NHS health care premises.

The design of fire safety in health care premises is covered by Health Technical Memorandum (HTM) 05-02 *Guidance in support of functional provisions for healthcare premises*. Part B of the Building Regulations will typically be satisfied where the guidance in that document is followed. Where work to existing healthcare premises is concerned the guidance in the appropriate section of the relevant *Firecode* should be followed.

## Unsupervised group homes

**0.22** Where an existing house of one or two storeys is to be put to use as an unsupervised group home for not more than six mental health service users, it should be regarded as a Purpose Group 1(c) building if the means of escape are provided in accordance with HTM 88: *Guide to fire precautions in NHS housing in the community for mentally handicapped (or mentally ill) people*. Where the building is new, it may be more appropriate to regard it as being in Purpose Group 2(b).

**Notes:** 1) *Firecode* contains managerial and other fire safety provisions which are outside the scope of Building Regulations.  
2) Where Regulation 37A applies Group homes in Wales shall comply with Section 2.

## Shopping complexes

**0.23** Although the guidance in this Approved Document may be readily applied to individual shops, shopping complexes present a different set of escape problems. The design of units within a shopping complex should be compatible with the fire strategy for the complex as a whole. A suitable approach is given in BS 5588-10:1991.

**Note:** BS 5588-10:1991 applies more restrictive provisions to units with only one exit in covered shopping complexes.

## Assembly buildings

**0.24** There are particular problems that arise when people are limited in their ability to escape by fixed seating. This may occur at sports events, theatres, lecture halls and conference centres etc. Guidance on this and other aspects of means of escape in assembly buildings is given in Sections 3 and 5 of BS 5588-6:1991 and the relevant recommendations concerning means of escape in case of fire of that code should be followed in appropriate cases. In the case of buildings to which the Safety



## General introduction

of Sports Grounds Act 1975 applies, the Guide to safety at sports grounds TSO (ISBN: 0 11341 001 8) should also be followed.

## Schools

**0.25** The design of fire safety in schools is covered by Building Bulletin (BB) 100 published by the DfES. Part B of the Building Regulations will typically be satisfied where the life safety guidance in that document is followed.

## Buildings containing one or more atria

**0.26** A building containing an atrium passing through compartment floors may need special fire safety measures. Guidance on suitable fire safety measures in these circumstances is to be found in BS 5588-7:1997 (see also paragraph 9.8). For shopping complexes see paragraph 0.23.

## Sheltered housing

**0.27** Whilst many of the provisions in this Approved Document for means of escape from flats are applicable to sheltered housing, the nature of the occupancy may necessitate some additional fire protection measures. The extent will depend on the form of the development. For example, a group of specially adapted bungalows or two-storey flats, with few communal facilities, need not be treated differently from other one or two-storey dwellinghouses or flats. Where Regulation 37A applies Sheltered housing in Wales shall comply with Section 2.

## Fire safety engineering

**0.28** Fire safety engineering can provide an alternative approach to fire safety. It may be the only practical way to achieve a satisfactory standard of fire safety in some large and complex buildings and in buildings containing different uses, e.g. airport terminals. Fire safety engineering may also be suitable for solving a problem with an aspect of the building design which otherwise follows the provisions in this document.

**0.29** British Standard BS 7974 Fire safety engineering in buildings and supporting published documents (PDs) provide a framework and guidance on the design and assessment of fire safety measures in buildings. Following the discipline of BS 7974 should enable designers and Building Control Bodies to be aware of the relevant issues, the need to consider the complete fire-safety system and to follow a disciplined analytical framework.

**0.30** Factors that should be taken into account include:

- a. the anticipated probability of a fire occurring;
- b. the anticipated fire severity;
- c. the ability of a structure to resist the spread of fire and smoke; and
- d. the consequential danger to people in and around the building.

## General introduction

- 0.31** A wide variety of measures could be considered and incorporated to a greater or lesser extent, as appropriate in the circumstances. These include:
- a. the adequacy of means to prevent fire;
  - b. early fire warning by an automatic detection and warning system;
  - c. the standard of means of escape;
  - d. provision of smoke control;
  - e. control of the rate of growth of a fire;
  - f. structural robustness and the adequacy of the structure to resist the effects of a fire;
  - g. the degree of fire containment;
  - h. fire separation between buildings or parts of buildings;
  - i. the standard of active measures for fire extinguishment or control;
  - j. facilities to assist the fire and rescue service;
  - k. availability of powers to require staff training in fire safety and fire routines;
  - l. consideration of the availability of any continuing control under other legislation that could ensure continued maintenance of such systems; and
  - m. management.
- 0.32** It is possible to use quantitative techniques to evaluate risk and hazard. Some factors in the measures listed above can be given numerical values in some circumstances. The assumptions made when quantitative methods are used need careful assessment.

## Buildings of special architectural or historic interest

- 0.33** Some variation of the provisions set out in this document may also be appropriate where Part B applies to existing buildings, particularly in buildings of special architectural or historic interest, where adherence to the guidance in this document might prove unduly restrictive. In such cases it would be appropriate to take into account a range of fire safety features, some of which are dealt with in this document and some of which are not addressed in any detail and to set these against an assessment of the hazard and risk peculiar to the particular case.

# Means of warning and escape B1

---

## The Requirements

This Approved Document deals with the following Requirement from Part B of Schedule 1 to the Building Regulations 2010.

Requirement	Limits on application
<p><b>Means of warning and escape</b></p> <p><b>B1.</b> The building shall be designed and constructed so that there are appropriate provisions for the early warning of fire, and appropriate means of escape in case of fire from the building to a place of safety outside the building capable of being safely and effectively used at all material times.</p>	<p>Requirement B1 does not apply to any prison provided under Section 33 of the Prison Act 1952 (power to provide prisons, etc.).</p> <p>(a) 1952 C.52; Section 33 was amended by Section 100 of the Criminal Justice and Public Order Act 1994 (C.33) and by S.I. 1963/597.</p>

# Guidance

# B1

## Performance

In Welsh Ministers' view the Requirement B1 will be met if:

- a. there are routes of sufficient number and capacity, which are suitably located to enable persons to escape to a place of safety in the event of fire;
- b. the routes are sufficiently protected from the effects of fire where necessary;
- c. the routes are adequately lit;
- d. the exits are suitably signed; and
- e. there are appropriate facilities to either limit the ingress of smoke to the escape route(s) or to restrict the fire and remove smoke;
- f. all to an extent necessary that is dependent on the use of the building, its size and height; and
- g. there is sufficient means for giving early warning of fire for persons in the building.

## Introduction

**B1.i** These provisions relate to building work and material changes of use which are subject to the functional requirement B1; they may therefore affect new or existing buildings. They are concerned with the measures necessary to ensure reasonable facilities for means of warning and escape in case of fire. They are only concerned with fire precautions where these are necessary to safeguard escape routes.

They assume that in the design of the building, reliance should not be placed on external rescue by the fire and rescue service nor should it be based on a presumption that they will attend an incident within a given time. This Approved Document has been prepared on the basis that, in an emergency, the occupants of any part of a building should be able to escape safely without any external assistance.

Special considerations, however, apply to some institutional buildings in which the principle of evacuation with assistance from staff is necessary.

## Analysis of the problem

**B1.ii** The design of means of escape and the provision of other fire safety measures, such as smoke alarms, should be based on an assessment of the risk to the occupants in the event of fire. The assessment should take into account the nature of the building structure; the use of the building; the potential of fire spread through the building; and the standard of fire safety management proposed. Where it is not possible to identify with any certainty any of these elements, a judgement as to the likely level of provision must be made.

## Means of warning

- B1.iii** Fires do not normally start in two different places in a building at the same time. Initially, a fire will create a hazard only in the part in which it starts and it is unlikely, at this stage, to involve a large area. The fire may subsequently spread to other parts of the building, usually along the circulation routes. The items that are the first to be ignited are often furnishings and other items not controlled by the Building Regulations. It is less likely that the fire will originate in the structure of the building itself and the risk of it originating accidentally in circulation areas is limited, provided that the combustible content of such areas is restricted.
- B1.iv** The primary danger associated with fire in its early stages is not flame but the smoke and noxious gases produced by the fire. They cause most of the casualties and may also obscure the way to escape routes and exits. Measures designed to provide safe means of escape must therefore provide appropriate arrangements to limit the rapid spread of smoke and fumes.

## Criteria for means of escape

**B1.v** The basic principles for the design of means of escape are:

- a. that there should be alternative means of escape from most situations; and
- b. where direct escape to a place of safety is not possible, it should be possible to reach a place of relative safety, such as a protected stairway, which is on a route to an exit, within a reasonable travel distance. In such cases the means of escape will consist of two parts, the first being unprotected in accommodation and circulation areas and the second in protected stairways (and in some circumstances protected corridors).

**Note:** Some people, for example those who use wheelchairs, may not be able to use stairways without assistance. For them evacuation involving the use of refuges on escape routes and either assistance down (or up) stairways or the use of suitable lifts will be necessary.

The ultimate place of safety is the open air clear of the effects of the fire. However, in modern buildings which are large and complex, reasonable safety may be reached within the building, provided suitable planning and protection measures are incorporated.

**B1.vi** For the purposes of Building Regulations, the following are not acceptable as means of escape:

- a. lifts (except for a suitably designed and installed evacuation lift – see paragraph 6.39);
- b. portable ladders and throw-out ladders; and
- c. manipulative apparatus and appliances, e.g. fold-down ladders and chutes.

## Means of warning

Escalators should not be counted as providing predictable exit capacity, although it is recognised that they are likely to be used by people who are escaping. Mechanised walkways could be accepted and their capacity assessed on the basis of their use as a walking route, while in the static mode.

## Alternative means of escape

**B1.vii** There is always the possibility of the path of a single escape route being rendered impassable by fire, smoke or fumes. Ideally, therefore people should be able to turn their backs on a fire wherever it occurs and travel away from it to a final exit or protected escape route leading to a place of safety. However, in certain conditions a single direction of escape (a dead end) can be accepted as providing reasonable safety. These conditions depend on the use of the building and its associated fire risk, the size and height of the building, the extent of the dead end and the numbers of persons accommodated within the dead end.

## Unprotected and protected escape routes

**B1.viii** The unprotected part of an escape route is that part which a person has to traverse before reaching either the safety of a final exit or the comparative safety of a protected escape route, i.e. a protected corridor or protected stairway.

Unprotected escape routes should be limited in extent so that people do not have to travel excessive distances while exposed to the immediate danger of fire and smoke.

Even with protected horizontal escape routes, the distance to a final exit or protected stairway needs to be limited because the structure does not give protection indefinitely.

**B1.ix** Protected stairways are designed to provide virtually 'fire sterile' areas which lead to places of safety outside the building. Once inside a protected stairway, a person can be considered to be safe from immediate danger from flame and smoke. They can then proceed to a place of safety at their own pace. To enable this to be done, flames, smoke and gases must be excluded from these escape routes, as far as is reasonably possible, by fire-resisting structures or by an appropriate smoke control system, or by a combination of both these methods. This does not preclude the use of unprotected stairs for day-to-day circulation, but they can only play a very limited role in terms of means of escape due to their vulnerability in fire situations.

## Security

**B1.x** The need for easy and rapid evacuation of a building in case of fire may conflict with the control of entry and exit in the interest of security. Measures intended to prevent unauthorised access can also hinder entry of the fire and rescue service to rescue people trapped by fire.

## Means of warning

Potential conflicts should be identified and resolved at the design stage and not left to ad hoc expedients after completion. The architectural liaison officers attached to most police forces are a valuable source of advice. Some more detailed guidance on door security in buildings is given in paragraphs 6.11 and 6.12.

## Use of the document

**B1.xi** Section 1 deals with fire alarm and fire detection systems in all buildings. Section 2 deals with automatic fire suppression systems. Section 3 deals with means of escape from blocks of flats and Sections 4 and 5 with buildings other than flats. Section 4 concerns the design of means of escape on one level (the horizontal phase in multi-storey buildings). Section 5 deals with stairways and the vertical phase of the escape route. Section 6 gives guidance on matters common to all parts of the means of escape.

## Section 1

## B1

# Fire detection and fire alarm system

### Introduction

**1.1** Provisions are made in this section for suitable arrangements to be made in all buildings to give early warning in the event of fire.

Paragraphs 1.2 to 1.23 deal with flats and paragraphs 1.24 to 1.37 with buildings other than flats. Paragraph 1.38 is applicable to all uses.

### Flats

**1.2** Provisions are made in this section for suitable arrangements to be made in flats to give early warning in the event of fire.

### General

**1.3** In most flats, the installation of smoke alarms or automatic fire detection and alarm systems, can significantly increase the level of safety by automatically giving an early warning of fire. The following guidance is appropriate for most flats. However, where it is known that the occupants of a proposed flat are at a special risk from fire, it may be more appropriate to provide a higher standard of protection (i.e. additional alarms).

**1.4** All new flats should be provided with a fire detection and fire alarm system in accordance with the relevant recommendations of BS 5839-6:2004 *Code of practice for the design, installation and maintenance of fire detection and fire alarm systems in dwellings* to at least a Grade D Category LD3 standard.

**1.5** The smoke and heat alarms should be mains-operated and conform to BS EN 14604: 2005, *Smoke alarm devices* or BS 5446-2: 2003, *Fire detection and fire alarm devices for dwellinghouses*, Part 2 Specification for heat alarms, respectively. They should have a standby power supply, such as a battery (either rechargeable or non-rechargeable) or capacitor. More information on power supplies is given in clause 15 of BS 5839-6:2004.

**Note:** BS EN 14604 covers smoke alarms based on ionization chamber smoke detectors and optical (photo-electric) smoke detectors. The different types of detector respond differently to smouldering and fast-flaming fires. Either type of detector is generally suitable. However, the choice of detector type should, if possible, take into account the type of fire that might be expected and the need to avoid false alarms. Optical detectors tend to be less affected by low levels of 'invisible' particles, such as fumes from kitchens that often cause false alarms. Accordingly, they are generally more suitable than ionization chamber detectors for installation in circulation spaces adjacent to kitchens.



## Section 1

### Material alterations

- 1.6** Where new habitable rooms are provided above the ground floor level, or where they are provided at ground floor level and there is no final exit from the new room, a fire detection and fire alarm system should be installed. Smoke alarms should be provided in the circulation spaces of the dwelling in accordance with paragraphs 1.10 to 1.18 to ensure that any occupants of the new rooms are warned of any fire that may impede their escape.

### Sheltered housing

- 1.7** The detection equipment in a sheltered housing scheme with a warden or supervisor should have a connection to a central monitoring point (or alarm receiving centre) so that the person in charge is aware that a fire has been detected in one of the flats and can identify the flat concerned. These provisions are not intended to be applied to the common parts of a sheltered housing development, such as communal lounges, or to sheltered accommodation in the Institutional or Other residential purpose groups. Means of warning in such facilities should be considered on a case by case basis following the general guidance for buildings other than flats given in paragraphs 1.24 to 1.38.

### Student accommodation

- 1.8** Some student residential accommodation is constructed in the same way as a block of flats. Where groups of up to six students share a self-contained flat with its own entrance door, constructed on the compartmentation principles for flats in Section 8 (B3), it is appropriate to provide a separate automatic detection system within each flat. Where a general evacuation is required (e.g. halls of residence), the alarm system should follow the guidance for buildings other than flats given in paragraphs 1.24. to 1.38.

### Positioning of smoke and heat alarms

- 1.9** Detailed guidance on the design and installation of fire detection and alarm systems in flats is given in BS 5839-6. However, the following guidance is appropriate to most common situations.
- 1.10** Smoke alarms should normally be positioned in the circulation spaces between sleeping spaces and places where fires are most likely to start (e.g. kitchens and living rooms) to pick up smoke in the early stages.
- 1.11** There should be at least one smoke alarm on every storey of a flat.
- 1.12** Where the kitchen area is not separated from the stairway or circulation space by a door, there should be a compatible interlinked heat detector or heat alarm in the kitchen, in addition to whatever smoke alarms are needed in the circulation space(s);
- 1.13** Where more than one alarm is installed they should be linked so that the detection of smoke by one unit operates the alarm signal in all of them.

## Section 1

The manufacturers' instructions about the maximum number of units that can be linked should be observed.

### 1.14 Smoke alarms/detectors should be sited so that:

- a. there is a smoke alarm in the circulation space within 7.5m of the door to every habitable room;
- b. they are ceiling-mounted and at least 300mm from walls and light fittings (unless in the case of light fittings there is test evidence to prove that the proximity of the light fitting will not adversely affect the efficiency of the detector). Units designed for wall-mounting may also be used provided that the units are above the level of doorways opening into the space and they are fixed in accordance with manufacturers' instructions; and
- c. the sensor in ceiling-mounted devices is between 25mm and 600mm below the ceiling (25-150mm in the case of heat detectors or heat alarms).

**Note:** This guidance applies to ceilings that are predominantly flat and horizontal.

**1.15** It should be possible to reach the smoke alarms to carry out routine maintenance, such as testing and cleaning, easily and safely. For this reason smoke alarms should not be fixed over a stair or any other opening between floors.

**1.16** Smoke alarms should not be fixed next to or directly above heaters or air-conditioning outlets. They should not be fixed in bathrooms, showers, cooking areas or garages, or any other place where steam, condensation or fumes could give false alarms.

**1.17** Smoke alarms should not be fitted in places that get very hot (such as a boiler room), or very cold (such as an unheated porch). They should not be fixed to surfaces which are normally much warmer or colder than the rest of the space, because the temperature difference might create air currents which move smoke away from the unit.

**1.18** A requirement for maintenance cannot be made as a condition of passing plans by the Building Control Body. However, the attention of developers and builders is drawn to the importance of providing the occupants with information on the use of the equipment and on its maintenance (or guidance on suitable maintenance contractors). See paragraph 0.14.

**Note:** BS 5839-1 and BS 5839-6 recommend that occupiers should receive the manufacturers' instructions concerning the operation and maintenance of the alarm system.

## Section 1

### Power supplies

- 1.19** The power supply for a smoke alarm system should be derived from the flat's mains electricity supply. The mains supply to the smoke alarm(s) should comprise a single independent circuit at the flat's main distribution board (consumer unit) or a single regularly used local lighting circuit. This has the advantage that the circuit is unlikely to be disconnected for any prolonged period. There should be a means of Isolating power to the smoke alarms without isolating the lighting.
- 1.20** The electrical installation should comply with Approved Document P (Electrical safety).
- 1.21** Any cable suitable for domestic wiring may be used for the power supply and interconnection to smoke alarm systems. It does not need any particular fire survival properties. Any conductors used for interconnecting alarms (signalling) should be readily distinguishable from those supplying mains power, e.g. by colour coding.

**Note:** Mains powered smoke alarms may be interconnected using radio-links, provided that this does not reduce the lifetime or duration of any standby power supply below 72 hours. In this case, the smoke alarms may be connected to separate power circuits (see paragraph 1.19)

- 1.22** Other effective options exist and are described in BS 5839: Parts 1 and 6. For example, the mains supply may be reduced to extra low voltage in a control unit incorporating a standby trickle-charged battery, before being distributed at that voltage to the alarms.

### Design and installation of systems

- 1.23** It is essential that fire detection and fire alarm systems are properly designed, installed and maintained. Where a fire alarm system is installed, an installation and commissioning certificate should be provided. Third party certification schemes for fire protection products and related services are an effective means of providing the fullest possible assurances, offering a level of quality, reliability and safety.

### Buildings other than flats

#### General

- 1.24** To select the appropriate type of fire alarm/ detection system that should be installed into a particular building, the type of occupancy and means of escape strategy (e.g. simultaneous, phased or progressive horizontal evacuation) must be determined.
- 1.25** For example, if occupants normally sleep on the premises e.g. residential accommodation, the threat posed by a fire is much greater than that in premises where the occupants are normally alert. Where the means of escape is based on simultaneous evacuation, operation of a manual call point or fire detector should give an almost instantaneous warning from all the fire alarm sounders. However, where the means of escape is based

## Section 1

on phased evacuation, then a staged alarm system is appropriate. Such a system enables two or more stages of alarm to be given within a particular area, e.g. “alert” or “evacuate” signals.

**Note:** the term fire detection system is used here to describe any type of automatic sensor network and associated control and indicating equipment. Sensors may be sensitive to smoke, heat, gaseous combustion products or radiation. Normally the control and indicating equipment operates a fire alarm system and it may perform other signalling or control functions as well. Automatic fire suppression systems can also be used to operate a fire alarm system.

**1.26** The factors which have to be considered when assessing what standard of fire alarm or automatic fire detection system is to be provided will vary widely from one set of premises to another. Therefore the appropriate standard will need to be considered on a case by case basis.

**Note:** General guidance on the standard of automatic fire detection that **may** need to be provided within a building can be found in Table A1 of BS 5839-1:2002.

### Fire alarm systems

- 1.27** All buildings should have arrangements for detecting fire. In most buildings fires are detected by people, either through observation or smell and therefore often nothing more will be needed.
- 1.28** In small buildings/premises the means of raising the alarm may be simple. For instance, where all occupants are near to each other a shouted warning “FIRE” by the person discovering the fire may be all that is needed. In assessing the situation, it must be determined that the warning can be heard and understood throughout the premises, including for example the toilet areas. In other circumstances, manually operated sounders (such as rotary gongs or handbells) may be used. Alternatively a simple manual call point combined with a bell, battery and charger may be suitable.
- 1.29** In all other cases, the building should be provided with a suitable electrically operated fire warning system with manual call points sited adjacent to exit doors and sufficient sounders to be clearly audible throughout the building.
- 1.30** An electrically operated fire alarm system should comply with BS 5839-1:2002 *Fire detection and alarm systems for buildings, Code of practice for system design, installation commissioning and maintenance*.

BS 5839-1 specifies three categories of system, i.e. category L for the protection of life; category M manual alarm systems; category P for property protection. Category L systems are sub-divided into:

## Section 1

- L1** – systems installed throughout the protected building;
- L2** – systems installed only in defined parts of the protected building (a category L2 system should normally include the coverage required of a category L3 system);
- L3** – systems designed to give a warning of fire at an early enough stage to enable all occupants, other than possibly those in the room of fire origin, to escape safely, before the escape routes are impassable owing to the presence of fire, smoke or toxic gases;
- L4** – systems installed within those parts of the escape routes comprising circulation areas and circulation spaces, such as corridors and stairways; and
- L5** – systems in which the protected area(s) and/or the location of detectors is designed to satisfy a specific fire safety objective (other than that of a category L1, L2, L3 or L4 system).

Type P systems are sub-divided into P1 – systems installed throughout the protected building and P2 – systems installed only in defined parts of the protected building.

- 1.31** Call points for electrical alarm systems should comply with BS 5839-2:1983, or Type A of BS EN 54-11:2001 and these should be installed in accordance with BS 5839-1. Type B call points should only be used with the approval of the Building Control Body.

BS EN 54-11 covers two types of call points, Type A (direct operation) in which the change to the alarm condition is automatic (i.e. without the need for further manual action) when the frangible element is broken or displaced; and Type B (indirect operation) in which the change to the alarm condition requires a separate manual operation of the operating element by the user after the frangible element is broken or displaced.

- 1.32** If it is considered that people might not respond quickly to a fire warning, or where people are unfamiliar with the fire warning arrangements, consideration may be given to installing a voice alarm system. Such a system could form part of a public address system and give both an audible signal and verbal instructions in the event of fire.

The fire warning signal should be distinct from other signals which may be in general use and be accompanied by clear verbal instructions.

If a voice alarm system is to be installed, it should comply with BS 5839-8:1998 *Code of practice for the design, installation and servicing of voice alarm systems*.

- 1.33** In certain premises, e.g. large shops and places of assembly, an initial general alarm may be undesirable because of the number of members of the public present. The need for fully trained staff to effect pre-planned procedures for safe evacuation will therefore be essential. Actuation of the fire alarm system will cause staff to be alerted, e.g. by discreet sounders,

## Section 1

personal paging systems etc. Provision will normally be made for full evacuation of the premises by sounders or a message broadcast over the public address system. In all other respects, any staff alarm system should comply with BS 5839-1.

### Warnings for people with impaired hearing

**1.34** A suitable method of warning (e.g. a visual and audible fire alarm signal) should be provided in buildings where it is anticipated that one or more persons with impaired hearing may be in relative isolation (e.g. hotel bedrooms and sanitary accommodation) and where there is no other suitable method of alerting them.

In buildings such as schools, colleges and offices where the population is controlled, a vibrating paging system may be more appropriate. This could also be used for alerting people with other disabilities.

Clause 18 of BS 5839-1:2002 provides detailed guidance on the design and selection of fire alarm warnings for people with impaired hearing.

### Automatic fire detection and fire alarm systems

**1.35** Automatic fire detection and alarms in accordance with BS 5839-1 should be provided in Institutional and Other residential occupancies.

**1.36** Automatic fire detection systems are not normally needed in non-residential occupancies. However, there are often circumstances where a fire detection system in accordance with BS 5839-1 may be needed. For example:

- a. to compensate for some departure from the guidance elsewhere in this document;
- b. as part of the operating system for some fire protection systems, such as pressure differential systems or automatic door releases;
- c. where a fire could break out in an unoccupied part of the premises (e.g. a storage area or basement that is not visited on a regular basis, or a part of the building that has been temporarily vacated) and prejudice the means of escape from any occupied part(s) of the premises.

**Note 1:** Guidance on the provision of automatic fire detection within a building which is designed for phased evacuation can be found in paragraph 5.29.

**Note 2:** Where an atrium building is designed in accordance BS 5588-7:1997, then the relevant recommendations in that code for the installation of fire alarm/fire detection systems for the design option(s) selected should be followed.

### Design and installation of systems

**1.37** It is essential that fire detection and fire warning systems are properly designed, installed and maintained. Where a fire alarm system is installed,

## Section 1

an installation and commissioning certificate should be provided. Third party certification schemes for fire protection products and related services are an effective means of providing the fullest possible assurances, offering a level of quality, reliability and safety (see paragraph 0.16).

### Interface between fire detection and fire alarm systems and other systems

**1.38** Fire detection and fire alarm systems are sometimes used to initiate the operation, or change of state, of other systems, such as smoke control systems, fire extinguishing systems, release arrangements for electrically held-open fire doors and electronically locked exit doors. It is essential that the interface between the fire detection and fire alarm system and any other system required for compliance with the Building Regulations is designed to achieve a high degree of reliability. Particular care should be taken if the interface is facilitated via another system, such as an access control system. Where any part of BS 7273 applies to actuation of other systems, the recommendations of that standard should be followed.

Section 2

## Section 2

## B1

### Automatic Fire Suppression Systems: Introduction Regulation 37A and 37B states:

Provision of automatic fire suppression systems

37A.—(1) This regulation applies where building work consists of the erection or material change of use of a building in relation to—

- (a) care homes as defined, means places at which a care home service, within the meaning of Part 1 of the Regulation and Inspection of Social Care (Wales) Act 2016, is provided wholly or mainly to persons aged 18 or over;
- (b) rooms for residential purposes other than rooms in—
  - (i) a hostel providing temporary accommodation to those who are ordinarily resident elsewhere;
  - (ii) an hotel;
  - (iii) a prison or young offender institution; and
  - (iv) a hospital
- (c) dwelling-houses and flats, subject to paragraphs (4) and (5).

(2) For the purposes of this regulation a material change of use comprises or includes a change of use within regulation 5 (a), (b), (c), (d), (g), (h) or (i).

(3) A building to which this regulation applies must be provided with an automatic fire suppression system which is installed and operates in accordance with the requirements set in regulation 37B.

(4) This regulation does not apply to buildings which are—

- (a) listed in accordance with section 1 of the Planning (Listed Buildings and Conservation Areas) Act 1990;
- (b) in a conservation area designated in accordance with section 69 of that Act; or
- (c) included in the schedule of monuments maintained under section 1 of the Ancient Monuments and Archaeological Areas Act 1979,

where installation of a fire suppression system would unacceptably alter their character or appearance.

(5) This regulation does not apply to temporary buildings with a planned time of use of two years or less.

Requirements of automatic fire suppression systems

37B. For the purposes of regulation 37A(3), the requirements of an automatic fire suppression system are the requirements set out in any document approved and issued under section 6 of the Building Act 1984 for the purpose of providing practical guidance as to the requirements of regulation 37A.”



## Section 2

### Introduction

- 2.1** Automatic fire suppression systems installed in buildings can reduce the risk to life and significantly reduce the degree of damage caused by fire. Automatic fire suppression systems can also sometimes be used as a compensatory feature where the provisions of this Approved Document are varied in some way.
- 2.2** Regulation 37A makes it a mandatory requirement for automatic fire suppression systems to be provided in all new premises (including those formed by a material change of use) of Purpose Groups 1a, 1b, 1c, 2a and 2b (subject to transitional provisions) erected in Wales with the exception of hospitals, hotels, prisons and a hostel providing temporary accommodation to those who are ordinarily resident elsewhere.

### General

- 2.3** Where an automatic fire suppression system is provided, it is normal practice to provide the automatic fire suppression system throughout a building to cover all areas required by the relevant technical standard. However, where the automatic fire suppression system is being installed as a compensatory feature to address a specific risk or hazard, it may be acceptable to protect only part of a building. Further guidance can also be found in *Sprinklers for Safety: Use and Benefits of Incorporating Sprinklers in Buildings and Structures*, BAFSA 2006 (ISBN: 0 95526 280 1) and *The Benefits of Automatic Fire Suppression Systems in Residential Care Premises*, BAFSA 2009.
- 2.4** Where an automatic fire suppression system is specifically required or recommended within this document it should be provided throughout the building or separated part and be designed and installed in accordance with an appropriate, fully implemented, technical standard such as:
- for dwellings and residential buildings, BS 9251: 2014 *Sprinkler systems for domestic and residential occupancies - Code of practice*. The components of the automatic fire suppression systems shall be installed to BS 9252: 2011 *Components for residential sprinkler systems – Specification and test methods for residential sprinklers.*; or
  - for non-residential buildings or dwellings and residential buildings outside the scope of the relevant technical standard, the requirements of BS EN 12845:2009, including the relevant hazard classification together with the special requirements for life safety systems. or;
  - an equivalent technical standard

**Note:** Any automatic fire suppression system installed to satisfy the requirements of Part B of the Building Regulations should be regarded as a life safety system. However, there may be some circumstances where a particular life safety requirement, specified in BS EN 12845 is inappropriate or unnecessary. Where an alternative technical standard (to BS 9251 or BS 9252) is used the guidance of Section 2.5 and Appendix A should be followed.

## Section 2

- 2.5** There are many alternative or innovative fire suppression systems available. Where these are used, it is necessary to ensure that such systems have been designed and tested for use in buildings and are fit for their intended purpose.

### Installation

- 2.6** The recommendations of Section 1.23 also apply to residential automatic fire suppression systems. It is essential that automatic fire suppression systems are properly designed, installed and maintained. Where an automatic fire suppression system is installed, an installation and commissioning certificate should be provided. Third party certification schemes for fire protection products and related services are an effective means of providing the fullest possible assurances, offering a level of quality, reliability and safety.
- 2.7** For the purposes of meeting the requirements of Regulation 37A relating to residential buildings:
- a. Where town mains are to be used, the designer must consult with the Water Undertaker to establish the typical operating water pressure range and flow capacities available.
  - b. Where town mains are to be used restrictions such as water meters shall not reduce the pressure and flow available below the performance specification detailed in the relevant technical standard.
  - c. Ancillary areas (such as a car port, car park, garage etc...) which are normally unoccupied do not require an automatic fire suppression system if they are suitably fire separated from the residential areas (See Tables A1 and A2). The minimum acceptable separation is 30 minutes integrity, insulation and stability.
- 2.8** Water supplies for non-residential automatic fire suppression systems designed and installed to BS EN 12845 should consist of:
- i. two single water supplies complying with BS EN 12845, clause 9.6.1 where each is independent of the other; or
  - ii. two stored water supplies, where:
    1. gravity or suction tanks should satisfy all the requirements of BS EN 12845 clause 9.6.2 b) other than capacity; and
    2. any pump arrangements should comply with BS EN 12845 clause 10.2 and
    3. the capacity of each tank is equivalent to half the specified minimum water volume of a single full capacity tank, appropriate to the hazard; or
    4. one tank should be at least equivalent to half the specified water volume of a single full capacity tank and the other shall not be less than the minimum volume of a reduced capacity tank BS EN12845 clause 9.3.4, appropriate to the hazard; and

**Note:** The requirement for inflow should be met.

5. whichever water storage arrangement is used at (3) or (4) above, the total capacity of the water supply, including any inflow for a reduced capacity

## Section 2

tank should be at least equivalent to a single full holding capacity tank complying with BS EN12845, Table 9, 10 or clause 9.3.2.3 as appropriate to the hazard and pipework design.

Where pumps are used to draw water from two tanks, then each pump should be arranged to draw water from either tank and arranged so that any one pump or either tank could be isolated.

The automatic fire suppression system water supplies should generally not be used as connections for other services or other fixed firefighting systems.

### Alternative designs for residential means of escape

**2.9** The guidance in Section 3 for means of escape deals with some common arrangements of residential buildings. Other, less common, arrangements (for example flats entered above or below accommodation level, or flats containing galleries or open plan layouts) are also acceptable where automatic fire suppression is provided.

Guidance on these is given in BS9991: 2011 and The NHBC and BRE *Open Plan Flat Layouts: Assessing life safety in the event of fire*.

### Material Alterations

**2.10** Where an existing residential property is not currently provided with an automatic fire suppression system and a material alteration is undertaken then the introduction of a suppression system to the new or existing areas of the building would not be required.

However, there will be some cases where the material alteration would result in significant changes to the existing means of escape strategy for the building or residence. Where this occurs an automatic fire suppression system may be required if the material alteration results in the fire safety provisions being less satisfactory than previously. This should be determined on a case by case basis. Reference should be made to paragraph 0.18.

## Section 3

## B1

# Means of escape from flats

### Introduction

**3.1** The means of escape from a flat with a floor not more than 4.5m above ground level is relatively simple to provide. Few provisions are specified in this document beyond ensuring that means are provided for giving early warning in the event of fire (see Section 1), automatic fire suppression is provided (see Section 2) and that suitable means are provided for emergency egress from these storeys.

With increasing height more complex provisions are needed because emergency egress through upper windows becomes increasingly hazardous.

**3.2** The guidance in this section deals with some common arrangements of flat design. Other, less common, arrangements (for example flats entered above or below accommodation level, or flats containing galleries) are acceptable as described in paragraph 2.9.

**3.3** The provisions for means of escape for flats are based on the assumption that:

- the fire is generally in a flat;
- there is no reliance on external rescue (e.g. by a portable ladder);
- measures in Section 9 (B3) provide a high degree of compartmentation and therefore a low probability of fire spread beyond the flat of origin, so that simultaneous evacuation of the building is unlikely to be necessary; and
- although fires may occur in the common parts of the building, the materials and construction used there should prevent the fabric from being involved beyond the immediate vicinity (although in some cases communal facilities exist which require additional measures to be taken).

**3.4** There are two distinct components to planning means of escape from buildings containing flats; escape from within each flat and escape from each flat to the final exit from the building.

Paragraphs 3.5 to 3.18 deal with the means of escape within each unit, i.e. within the private domestic area. Paragraphs 3.19 to 3.48 deal with the means of escape in the common areas of the building. Guidance on mixed use buildings is given in paragraphs 3.50 to 3.51 and for live/ work units in 3.52.

### General provisions

#### Inner rooms

**3.5** A room whose only escape route is through another room is at risk if a fire starts in that other room.

This situation may arise with open-plan layouts and galleries. Such an arrangement is only acceptable where the inner room is:

### Section 3

- a. a kitchen;
- b. a laundry or utility room;
- c. a dressing room;
- d. a bathroom, WC, or shower room;
- e. any other room on a floor not more than 4.5m above ground level which complies with paragraph 3.6, 3.10, or 3.11b as appropriate; or
- f. a gallery which complies with paragraph 3.8.

**Note:** A room accessed only via an inner room (an inner-inner room) may be acceptable if it complies with the above, not more than one door separates the room from an interlinked smoke alarm and none of the access rooms are a kitchen.

### Basements

**3.6** Because of the risk that a single stairway may be blocked by smoke from a fire in the basement or ground storey, if the basement storey contains any habitable room, either provide:

- a. an external door or window suitable for egress from the basement (see paragraph 3.9); or
- b. a protected stairway leading from the basement to a final exit.

### Balconies and flat roofs

**3.7** Any balcony outside an alternative exit to a flat more than 4.5m above ground level should be a common balcony and meet the conditions in paragraph 3.17.

A flat roof forming part of a means of escape should comply with the following provisions:

- a. the roof should be part of the same building from which escape is being made;
- b. the route across the roof should lead to a storey exit or external escape route; and
- c. the part of the roof forming the escape route and its supporting structure, together with any opening within 3m of the escape route, should provide 30 minutes fire resistance (see Appendix A Table A1).

**Note:** Where a balcony or flat roof is provided for escape purposes, guarding may be needed, in which case it should meet the provisions in Approved Document K *Protection from falling, collision and impact*.

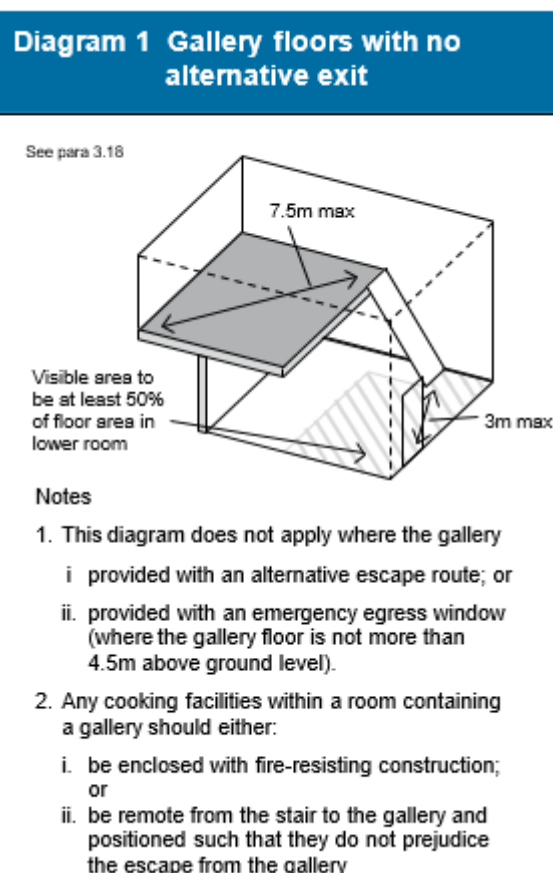
### Galleries

**3.8** A gallery should be provided with an alternative exit; or, where the gallery floor is not more than 4.5m above ground level, an emergency egress window which complies with paragraph 3.9. Where the gallery floor is not provided with an alternative exit or escape window, it should comply with the following:

- a. the gallery should overlook at least 50% of the room below (see Diagram1);
- b. the distance between the foot of the access stair to the gallery and the door to the room containing the gallery should not exceed 3m;

### Section 3

- c. the distance from the head of the access stair to any point on the gallery should not exceed 7.5m; and
- d. any cooking facilities within a room containing a gallery should either:
  - i. be enclosed with fire-resisting construction; or
  - ii. be remote from the stair to the gallery and positioned such that they do not prejudice the escape from the gallery.



## Emergency egress windows and external doors

**3.9** Any window provided for emergency egress purposes should comply with the following conditions:

- a. the window should have an unobstructed openable area that is at least  $0.33\text{m}^2$  and at least 450mm high and 450mm wide (the route through the window may be at an angle rather than straight through). The bottom of the openable area should be not more than 1100mm above the floor; and
- b. the window should enable the person escaping to reach a place free from danger from fire.

**Note 1:** Approved Document K *Protection from falling, collision and impact* specifies a minimum guarding height of 800mm, except in the case of a window in a roof where the bottom of the opening may be 600mm above the floor.

## Section 3

**Note 2:** Locks (with or without removable keys) and stays may be fitted to egress windows, subject to the stay being fitted with a release catch, which may be child resistant.

**Note 3:** Windows should be designed such that they will remain in the open position without needing to be held by a person making their escape.

### Provisions for escape from flats where the floor is not more than 4.5m above ground level

**3.10** The internal arrangement of flats (single or multi-storey) where no floor is more than 4.5m in height may either meet the provisions in paragraphs 3.11 to 3.12 or 3.13 to 3.18.

**Note:** Where a flat is accessed via the common parts of a block of flats it may be necessary to provide a protected entrance hall to meet the provisions of Paragraph 3.21 and Diagram 9.

### Provisions for escape from the ground storey

**3.11** Except for kitchens, all habitable rooms in the ground storey should either:

- a. open directly onto a hall leading to the entrance or other suitable exit: or
- b. be provided with a window (or door) which complies with paragraph 3.9;

### Provisions for escape from upper floors not more than 4.5m above ground level

**3.12** Except for kitchens, all habitable rooms in the upper storey(s) should be provided with:

- a. a window (or external door) which complies with paragraph 3.9; or
- b. in the case of a multi-storey flat, direct access to its own internal protected stairway leading to a final exit.

**Note:** A single window can be accepted to serve two rooms provided both rooms have their own access to the stairs. A communicating door between the rooms must be provided so that it is possible to gain access to the window without passing through the stair enclosure.

### Provisions for flats with a floor more than 4.5m above ground level Internal planning of flats

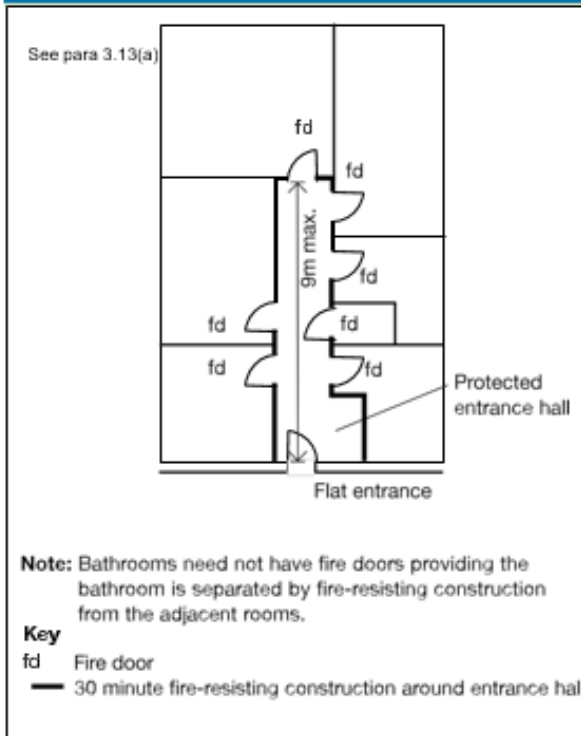
**3.13** Three acceptable approaches (all of which should observe the restrictions concerning inner rooms given in paragraph 3.5) when planning a flat which has a floor at more than 4.5m above ground level are:

- a. to provide a protected entrance hall which serves all habitable rooms, planned so that the travel distance from the entrance door to the door to any habitable room is 9m or less (see Diagram 2); or
- b. to plan the flat so that the travel distance from the entrance door to any point in any of the habitable rooms does not exceed 9m and the cooking facilities are remote from the entrance door and do not prejudice the escape route

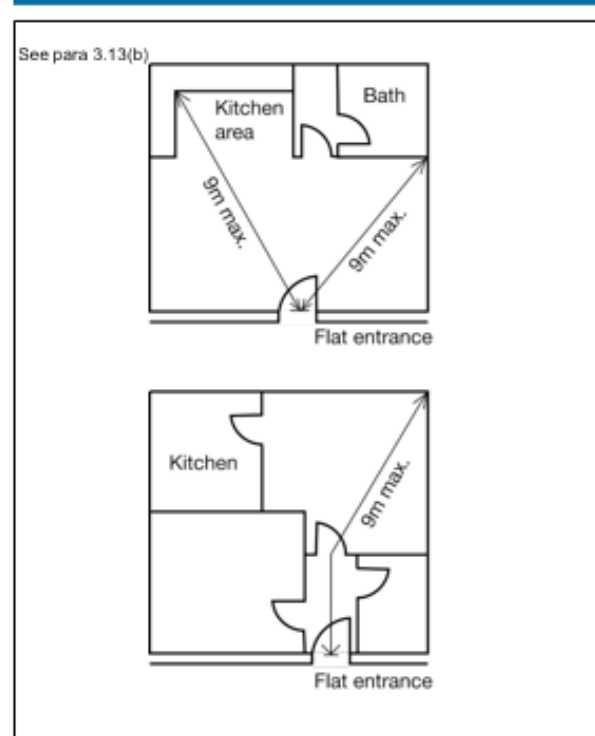
Section 3

- from any point in the flat (see Diagram 3); or
- c. to provide an alternative exit from the flat, complying with paragraph 3.14.

**Diagram 2 Flat where all habitable rooms have direct access to an entrance hall**



**Diagram 3 Flat with restricted travel distance from furthest point to entrance**



**3.14** Where any flat has an alternative exit and the habitable rooms do not have direct access to the entrance hall (see Diagram 4):

- a. the bedrooms should be separated from the living accommodation by fire-resisting construction and fire door(s); and
- b. the alternative exit should be located in the part of the flat containing the bedroom(s).

**Internal planning of flats with more than one storey**

**3.15** A multi-storey flat with an independent external entrance at ground level is similar to a dwellinghouse and means of escape should be planned on the basis of paragraphs 3.11 or 3.12 depending on the height of the top storey above ground level.

**3.16** Four acceptable approaches to planning a multi-storey flat, which does not have its own external entrance at ground level but has a floor at more than 4.5m above ground level, are:



### Section 3

- a. to provide an alternative exit from each habitable room which is not on the entrance floor of the flat, (see Diagram 5); or
- b. to provide one alternative exit from each floor (other than the entrance floor), with a protected landing entered directly from all the habitable rooms on that floor, (see Diagram 6); or
- c. to provide a protected stairway (smoke alarms should also be provided in accordance with paragraph 1.9).

Where an existing un-sprinklered building is being extended to include a storey more than 4.5m above ground level the acceptable approaches are:

- a. Flat designed in line with Paragraph 3.16 a and 3.16 b.
- b. where the vertical distance between the floor of the entrance storey and the floors above and below it does not exceed 7.5m, to provide a protected stairway plus additional smoke alarms in all habitable rooms and a heat alarm in any kitchen.
- c. to provide a protected stairway plus an automatic fire suppression system in accordance with Section 2 (smoke alarms should also be provided in accordance with paragraph 1.9).

### Alternative exits

**3.17** To be effective, an alternative exit from a flat should satisfy the following conditions:

- a. be remote from the main entrance door to the flat; and
- b. lead to a final exit or common stair by way of:
  - i. a door onto an access corridor, access lobby or common balcony; or
  - ii. an internal private stair leading to an access corridor, access lobby or common balcony at another level; or
  - iii. a door into a common stair; or
  - iv. a door onto an external stair; or
  - v. a door onto an escape route over a flat roof.

**Note:** Any such access to a final exit or common stair should meet the appropriate provisions dealing with means of escape in the common parts of the building (see paragraph 3.19).

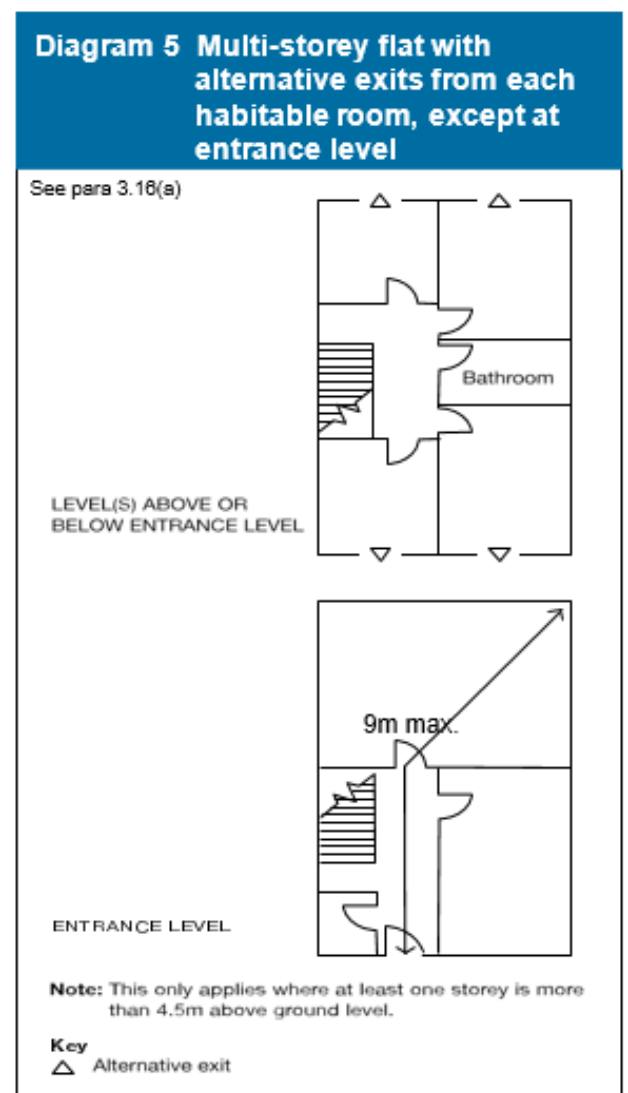
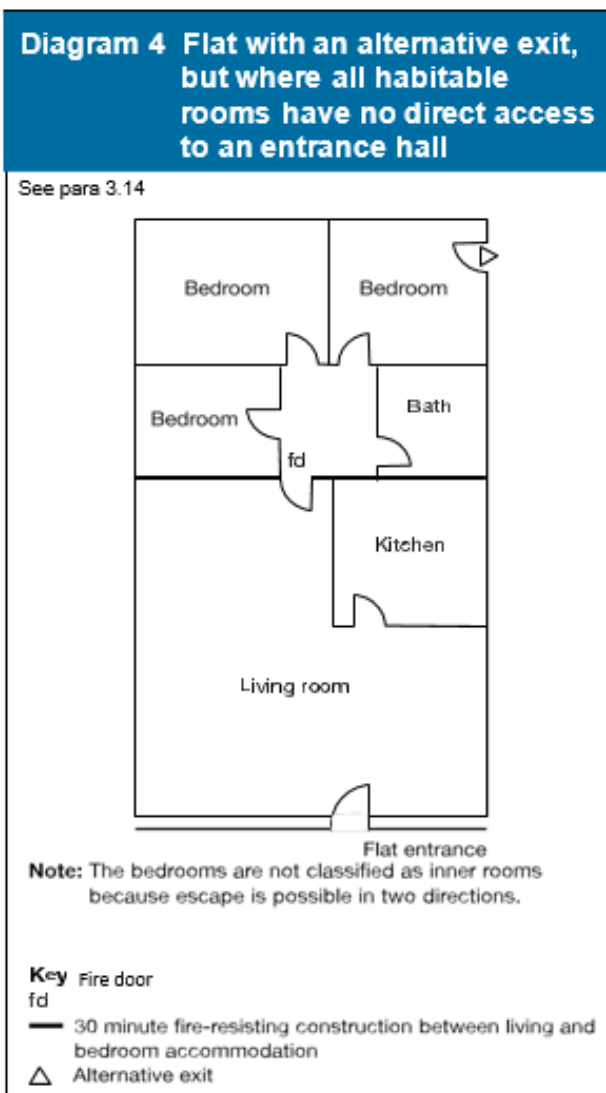
### Air circulation systems in flats with a protected stairway or entrance hall

**3.18** Where ventilation ducts pass through compartment walls, then the guidance given paragraphs 6.46 to 6.53, 9.40 and 11.9 to 11.15 should be followed. Where an air circulation system circulates air only within an individual flat with an internal protected stairway or entrance hall the following precautions are needed to avoid the possibility of the system allowing smoke or fire to spread into the protected space.

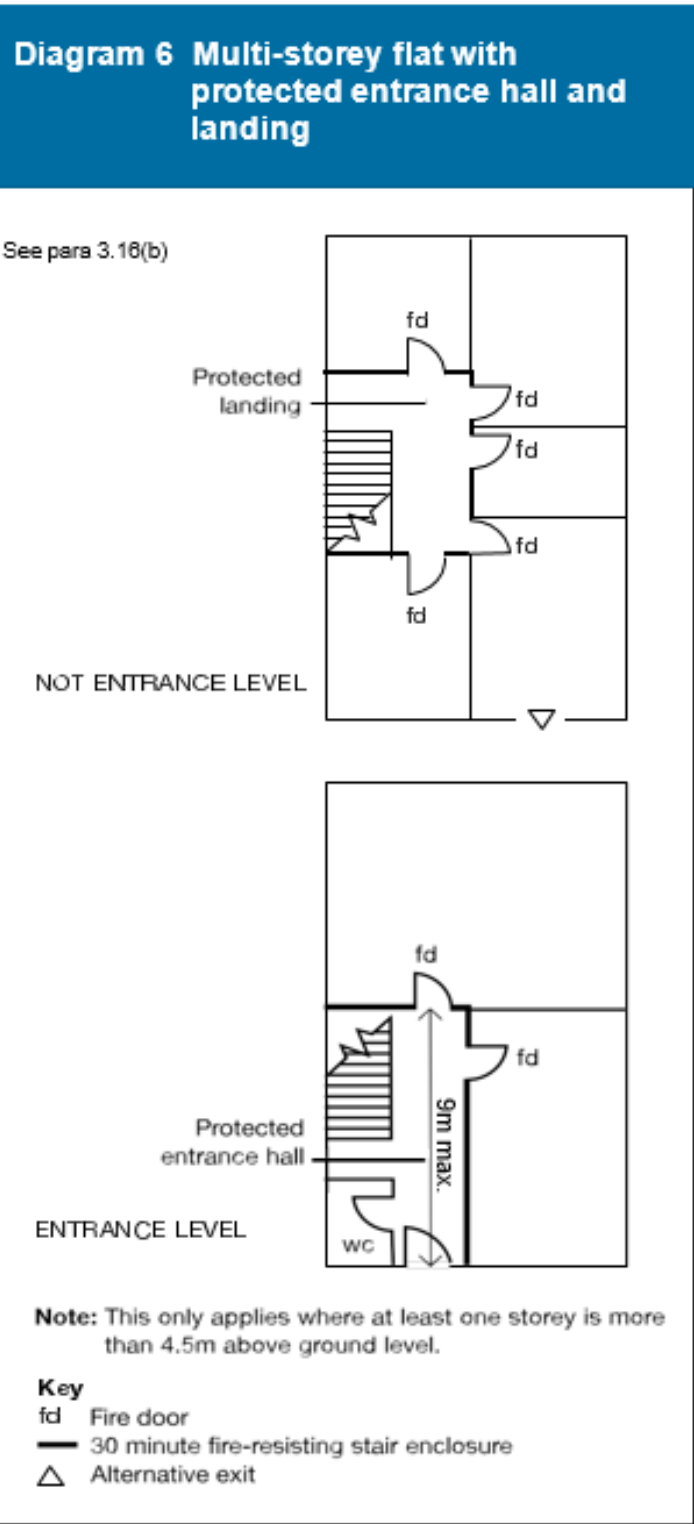
- a. Transfer grilles should not be fitted in any wall, door, floor or ceiling enclosing a protected stairway or entrance hall;

**Section 3**

- b. Any duct passing through the enclosure to a protected stairway or entrance hall should be of rigid steel construction and all joints between the ductwork and the enclosure should be fire-stopped,
- c. Ventilation ducts supplying or extracting air directly to or from a protected stairway or entrance hall, should not also serve other areas;
- d. Any system of mechanical ventilation which recirculates air and which serves both the stairway or entrance hall and other areas should be designed to shut down on the detection of smoke within the system; and
- e. A room thermostat for a ducted warm air heating system should be mounted in the living room at a height between 1370mm and 1830mm and its maximum setting should not exceed 27°C.



Section 3



## Section 3

### Means of escape in the common parts of flats

**3.19** The following paragraphs deal with means of escape from the entrance doors of flats to a final exit. They should be read in conjunction with the general provisions in Section 6.

**Note:** Paragraphs 3.20 to 3.51 are not applicable where the top floor is not more than 4.5m above ground level and the flats are designed in accordance with paragraphs 3.11 and 3.12. However, attention is drawn to the provisions in paragraph 0.27 regarding sheltered housing, Section 6 regarding general provisions, Section 9 (B3) regarding the provision of compartment walls and protected shafts and Section 17 (B5) regarding the provision of access for the Fire and Rescue Service.

### Number of escape routes

**3.20** Every flat should have access to alternative escape routes so that a person confronted by the effects of an outbreak of fire in another flat can turn away from it and make a safe escape.

However, a single escape route from the flat entrance door is acceptable if either:

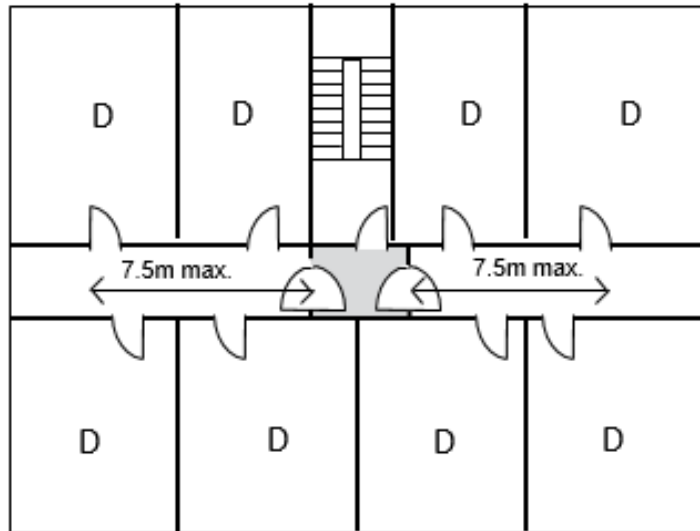
- a. the flat is situated in a storey served by a single common stair and:
  - i. every flat is separated from the common stair by a protected lobby or common corridor (see Diagram 7); and
  - ii. the travel distance limitations in Table 1 (see paragraph 3.23), on escape in one direction only, are observed; or
- b. alternatively the flat is situated in a dead end part of a common corridor served by two (or more) common stairs and the travel distance complies with the limitations in Table 1 on escape in one direction only (see Diagram 8).

Section 3

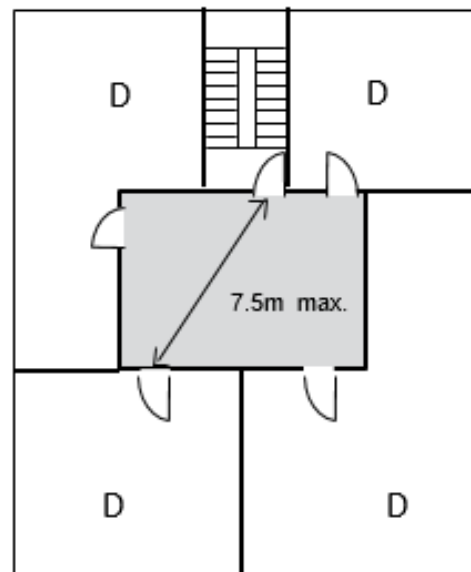
Diagram 7 Flats served by one common stair

See para 3.20(a) and 3.25

a. CORRIDOR ACCESS DWELLINGS



b. LOBBY ACCESS DWELLINGS



Notes

1. The arrangements shown also apply the top storey.
2. See Diagram 9 for small single stair buildings.
3. All doors shown are fire doors.
4. Where travel distance is measured to a stair lobby, the lobby must not provide direct access to any storage room, flat or other space containing a potential fire hazard.

Key

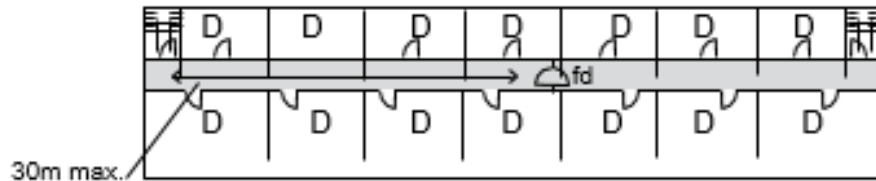
- D Dwelling
- Shaded area indicates zone where ventilation should be provided in accordance with paragraph 3.26 (An external wall vent or smoke shaft located anywhere in the shaded area)

Section 3

**Diagram 8 Flats served by more than one common stair**

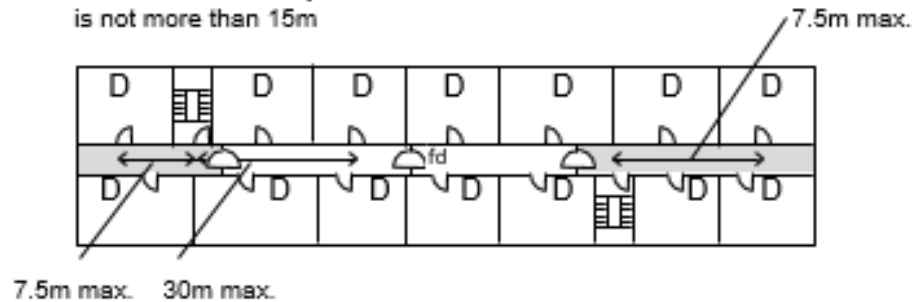
See para 3.20(b) and 3.28

a. CORRIDOR ACCESS WITHOUT DEAD ENDS



b. CORRIDOR ACCESS WITH DEAD ENDS

The central door may be omitted if maximum travel distance is not more than 15m

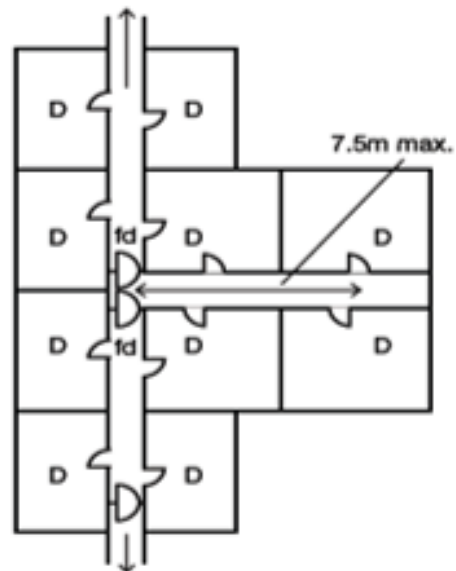


c. 'T' JUNCTION WITH MAIN CORRIDOR

**Note:**  
The arrangements shown also apply to the top storey.

**Key**  
D Dwelling  
fd Fire door

■ Shaded area indicates zone where ventilation should be provided in accordance with paragraph 3.28 (An external wall vent or smoke shaft located anywhere in the shaded area)



## Section 3

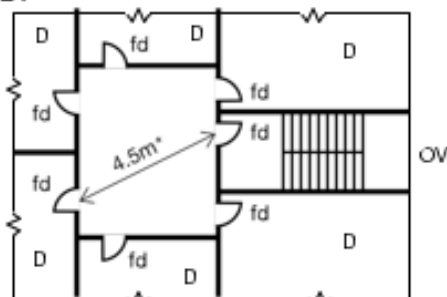
### Small single-stair buildings

**3.21** The provisions in paragraph 3.20 may be modified and a single stair, protected in accordance with Diagram 9, may be used provided that:

- the top floor of the building is no more than 11m above ground level;
- there are no more than 3 storeys above the ground level storey;
- the stair does not connect to a covered car park except if the car park is open sided (see paragraph 12.3 for meaning of open-sided car park);
- the stair does not serve ancillary accommodation unless the ancillary accommodation is separated from the stair by a protected lobby, or protected corridor, which has not less than  $0.4\text{m}^2$  permanent ventilation or is protected from the ingress of smoke by a mechanical smoke control system; and
- a high level openable vent, for fire and rescue service, use is provided at each floor level with a minimum free area of  $1\text{m}^2$ . Alternatively, a single openable vent may be provided at the head of the stair which can be remotely operated from fire and rescue service access level.

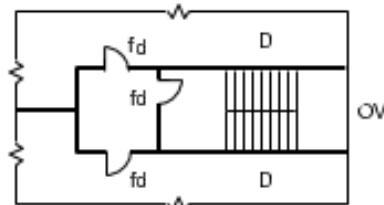
#### Diagram 9 Common escape route in small single stair building

See para 3.21



a. SMALL SINGLE STAIR BUILDING

\*If smoke control is provided in the lobby, the travel distance can be increased to 7.5m maximum (see Diagram 7, example b).



b. SMALL SINGLE STAIR BUILDING WITH NO MORE THAN 2 DWELLINGS PER STOREY

The door between stair and lobby should be free from security fastenings

If the dwellings have protected entrance halls, the lobby between the common stair and dwelling entrance is not essential.

#### Notes:

- The arrangements shown also apply to the top storey.
- If the travel distance across the lobby in Diagram 9a exceeds 4.5m, Diagram 7 applies.
- Where, in Diagram 9b, the lobby between the common stair and the dwelling is omitted in small single-stair buildings, an automatic opening vent with a geometric free area of a least  $1.0\text{m}^2$  is required at the top of the stair, to be operated on detection of smoke at any storey in the stair.

#### Key

- Fire-resisting construction
- OV Openable vent at high level for fire service use ( $1.0\text{m}^2$  minimum free area) see paragraph 3.21e
- D Dwelling
- fd Fire door

Section 3

## Flats with balcony or deck access

**3.22** The provisions of paragraph 3.20 may also be modified in the case of flats with balcony or deck approach. Guidance on these forms of development is set out in clause 13 of BS 5588-1:1990.

**Table 1 Limitations on distance of travel in common areas of blocks of flats (see paragraph 3.23)**

Maximum distance of travel (m) from flat entrance door to common stair, or to stair lobby <sup>(4)</sup>	
Escape in one direction only	Escape in more than one direction
7.5m <sup>(1)(2)</sup>	30m <sup>(2)(3)</sup>

**Notes:**

1. Reduced to 4.5m in the case shown in Diagram 9.
2. Where all flats on a storey have independent alternative means of escape, the maximum distance of travel does not apply. However, see paragraph 17.3 (B5) which specifies Fire and Rescue Service access requirements.
3. For sheltered housing, see paragraph 0.27.
4. Where travel distance is measured to a stair lobby, the lobby must not provide direct access to any storage room, flat or other space containing a potential fire hazard.

## Planning of common escape routes

**3.23** Escape routes in the common areas should comply with the limitations on travel distance in Table 1. However, there may be circumstances where some increase on these maximum figures will be reasonable.

Escape routes should be planned so that people do not have to pass through one stairway enclosure to reach another. However, it is acceptable to pass through a protected lobby of one stairway in order to reach another.

## Protection of common escape routes

**3.24** To reduce the risk of a fire in a flat affecting the means of escape from other flats and common parts of the building, the common corridors should be protected corridors.

The wall between each flat and the corridor should be a compartment wall (see Section 9).

**Note:** This document assumes that a building will be appropriately managed (see Paragraph 0.13). In most cases an automatic fire suppression system need only be provided within the individual flats, they would not normally be required in the common areas such as stairs, corridors or landings. However, if there are concerns at the design stage related to fire safety management or the level of fire safety management is unknown, the provision of automatic fire suppression may provide suitable risk reduction measures within those common areas, particularly where a single means of escape exists. This would need to be assessed on a case by case basis in consultation with the relevant approval authorities.



## Section 3

### Smoke control of common escape routes

**3.25** Despite the provisions described in this Approved Document, it is probable that some smoke will get into a common corridor or lobby from a fire in a flat, if only because the entrance door will be opened when the occupants escape.

There should therefore be some means of ventilating the common corridors/lobbies to control smoke and so protect the common stairs. This offers additional protection to that provided by the fire doors to the stair. (The ventilation also affords some protection to the corridors/lobbies.)

This can be achieved by either natural means in accordance with paragraph 3.26 or by means of mechanical ventilation as described in paragraph 3.27.

### Smoke control of common escape routes by natural smoke ventilation

**3.26** In buildings, other than small ones complying with Diagram 9, the corridor or lobby adjoining the stair should be provided with a vent. The vent from the corridor/lobby should be located as high as practicable and such that the top edge is at least as high as the top of the door to the stair.

There should also be a vent, with a free area of at least 1.0m<sup>2</sup>, from the top storey of the stairway to the outside.

In single stair buildings the smoke vents on the fire floor and at the head of the stair should be actuated by means of smoke detectors in the common access space providing access to the flats. In buildings with more than one stair the smoke vents may be actuated manually (and accordingly smoke detection is not required for ventilation purposes). However, where manual actuation is used, the control system should be designed to ensure that the vent at the head of the stair will be opened either before, or at the same time, as the vent on the fire floor.

Vents should either:

- a. be located on an external wall with minimum free area of 1.5m<sup>2</sup> (see Appendix C); or
- b. discharge into a vertical smoke shaft (closed at the base) meeting the following criteria:
  - i. Minimum cross-sectional area 1.5m<sup>2</sup> (minimum dimension 0.85m in any direction), opening at roof level at least 0.5m above any surrounding structures within a horizontal distance of 2.0m. The shaft should extend at least 2.5m above the ceiling of the highest storey served by the shaft;
  - ii. The minimum free area of the vent from the corridor/lobby into the shaft and at the opening at the head of the shaft and at all internal locations within the shaft (e.g. safety grilles) should be at least 1.0m<sup>2</sup> (see Appendix C);
  - iii. The smoke shaft should be constructed from non-combustible material and all vents should have a fire/smoke resistance performance at least that of an E30S<sub>a</sub> fire door. The shaft should be vertical from base to head, with no more than 4m at an inclined angle (maximum 30°); and

## Section 3

- iv. On detection of smoke in the common corridor/lobby, the vent(s) on the fire floor, the vent at the top of the smoke shaft and to the stairway should all open simultaneously. The vents from the corridors/lobbies on all other storeys should remain closed.

### Smoke control of common escape routes by mechanical ventilation

**3.27** As an alternative to the natural ventilation provisions in paragraph 3.26, mechanical ventilation to the stair and/or corridor/lobby may be provided to protect the stair(s) from smoke. Guidance on the design of smoke control systems using pressure differentials is available in BS EN 12101-6:2005.

### Sub-division of common escape routes

**3.28** A common corridor that connects two or more storey exits should be sub-divided by a self-closing fire door with, if necessary, any associated fire-resisting screen (see Diagram 8). The door(s) should be positioned so that smoke will not affect access to more than one stairway.

**3.29** A dead-end portion of a common corridor should be separated from the rest of the corridor by a self-closing fire door with, if necessary, any associated fire-resisting screen (see Diagram 7a and Diagram 8b and 8c).

### Ancillary accommodation, etc.

**3.30** Stores and other ancillary accommodation should not be located within, or entered from, any protected lobby or protected corridor forming part of the only common escape route from a flat on the same storey as that ancillary accommodation.

Reference should be made to paragraphs 6.54 to 6.57 for special provisions for refuse chutes and storage areas.

### Escape routes over flat roofs

**3.31** If more than one escape route is available from a storey, or part of a building, one of those routes may be by way of a flat roof provided that it complies with the provisions in paragraph 6.35.

**Note:** Access to designs described in paragraph 3.48 may also be via a flat roof if the route over the roof complies with the provisions in paragraph 6.35.

### Common stairs

#### Number of common stairs

**3.32** As explained in paragraph 3.19 and paragraph 3.20 a single common stair can be acceptable in some cases, but otherwise there should be access to more than one common stair for escape purposes.

#### Width of common stairs

**3.33** A stair of acceptable width for everyday use will be sufficient for escape purposes, but if it is also a firefighting stair, it should be at least 1100mm wide (see Appendix C for measurement of width).

## Section 3

### Protection of common stairs

- 3.34** Common stairs need to have a satisfactory standard of fire protection if they are to fulfill their role as areas of relative safety during a fire evacuation. The provisions in paragraphs 3.35 to 3.46 should be followed.
- 3.35** Stairs provide a potential route for fire spread from floor to floor. In Section 8 under the requirement of B3 to inhibit internal fire spread, there is guidance on the enclosure of stairs to avoid this. A stair may also serve as a firefighting stair in accordance with the requirement B5, in which case account will have to be taken of the guidance in Section 18.

### Enclosure of common stairs

- 3.36** Every common stair should be situated within a fire-resisting enclosure (i.e. it should be a protected stairway), to reduce the risk of smoke and heat making use of the stair hazardous.
- 3.37** The appropriate level of fire resistance is given in Appendix A, Tables A1 and A2.

### Exits from protected stairways

- 3.38** Every protected stairway should discharge:
- directly to a final exit; or
  - by way of a protected exit passageway to a final exit.

**Note:** Any such protected exit passageway should have the same standard of fire resistance and lobby protection as the stairway it serves.

### Separation of adjoining protected stairways

- 3.39** Where two protected stairways (or exit passageways leading to different final exits) are adjacent, they should be separated by an imperforate enclosure.

### Use of space within protected stairways

- 3.40** A protected stairway needs to be relatively free of potential sources of fire. Consequently, it should not be used for anything else, except a lift well or electricity meter(s). There are other provisions for lifts in paragraphs 6.39 to 6.45. In single stair buildings, meters located within the stairway should be enclosed within a secure cupboard which is separated from the escape route with fire-resisting construction.

### Fire resistance and openings in external walls of protected stairways

- 3.41** The external enclosures to protected stairways should meet the provisions in paragraph 6.24.

### Gas service and installation pipes in protected stairways

- 3.42** Gas service and installation pipes or associated meters should not be incorporated within a protected stairway unless the gas installation is in accordance with the requirements for installation and connection set out in the Pipelines Safety Regulations 1996, SI 1996 No 825 and the Gas Safety

## Section 3

(Installation and Use) Regulations 1998 SI 1998 No 2451 (see also paragraph 9.40).

### Basement stairs

**3.43** Because of their situation, basement stairways are more likely to be filled with smoke and heat than stairs in ground and upper storeys.

Special measures are therefore needed in order to prevent a basement fire endangering upper storeys. These are set out in the following two paragraphs.

**3.44** If an escape stair forms part of the only escape route from an upper storey of a building (or part of a building) which is not a small building (see paragraph 3.20), it should not be continued down to serve any basement storey. The basement should be served by a separate stair.

**3.45** If there is more than one escape stair from an upper storey of a building (or part of a building), only one of the stairs serving the upper storeys of the building (or part) need be terminated at ground level. Other stairs may connect with the basement storey(s) if there is a protected lobby or a protected corridor between the stair(s) and accommodation at each basement level.

### Stairs serving accommodation ancillary to flats

**3.46** Except in small buildings described in paragraph 3.21, where a common stair forms part of the only escape route from a flat, it should not also serve any covered car park, boiler room, fuel storage space or other ancillary accommodation of similar fire risk.

**3.47** Any common stair which does not form part of the only escape route from a flat may also serve ancillary accommodation if it is separated from the ancillary accommodation by a protected lobby or a protected corridor.

If the stair serves an enclosed (non open-sided) car park, or place of special fire hazard, the lobby or corridor should have not less than 0.4m<sup>2</sup> permanent ventilation or be protected from the ingress of smoke by a mechanical smoke control system.

### External escape stairs

**3.48** If the building (or part of the building) is served by a single access stair, that stair may be external if it:

- a. serves a floor not more than 6m above the ground level; and
- b. meets the provisions in paragraph 6.25.

**3.49** Where more than one escape route is available from a storey (or part of a building), some of the escape routes from that storey or part of the building may be by way of an external escape stair, provided that there is at least one internal escape stair from every part of each storey (excluding plant areas) and the external stair(s):

### Section 3

- a. serves a floor not more than 6m above either the ground level or a roof or podium which is itself served by an independent protected stairway; and
- b. meets the provisions in paragraph 6.25.

### Flats in mixed use buildings

**3.50** In buildings with not more than three storeys above the ground storey, stairs may serve both flats and other occupancies, provided that the stairs are separated from each occupancy by protected lobbies at all levels.

**3.51** In buildings with more than three storeys above the ground storey, stairs may serve both flats and other occupancies provided that:

- a. the flat is ancillary to the main use of the building and is provided with an independent alternative escape route;
- b. the stair is separated from any other occupancies on the lower storeys by protected lobbies (at those storey levels);

**Note:** The stair enclosure should have at least the same standard of fire resistance as stipulated in Table A2 for the elements of structure of the building (and take account of any additional provisions in Section 18 if it is a firefighting stair).

- c. any automatic fire detection and alarm system with which the main part of the building is fitted also covers the flat;
- d. any security measures should not prevent escape at all material times.

**Note:** Additional measures, including increased periods of fire resistance may be required between the flat and any storage area where fuels such as petrol and LPG are present.

### Live/work units

**3.52** Where a flat is intended to serve as a workplace for its occupants and for persons who do not live on the premises, the following additional fire precautions will be necessary:

- a. The maximum travel distance to the flat entrance door or an alternative means of escape (not a window) from any part of the working area should not exceed 18m; and
- b. Any windowless accommodation should have escape lighting which illuminates the route if the main supply fails. Standards for the installation of a system of escape lighting are given in BS 5266-1:2005.

**Note:** Where the unit is so large that the travel distance in a. cannot be met then the assumptions set out in paragraph 3.3 may no longer be valid. In such circumstances the design of the building should be considered on a case by case basis.

## Section 4

## B1

# Design for horizontal escape – buildings other than flats

### Introduction

**4.1** The general principle to be followed when designing facilities for means of escape is that any person confronted by an outbreak of fire within a building can turn away from it and make a safe escape. This Section deals with the provision of means of escape from any point to the storey exit of the floor in question, for all types of building. It should be read in conjunction with the guidance on the vertical part of the escape route in Section 5 and the general provisions in Section 6.

It should be noted that guidance in this Section is directed mainly at smaller, simpler types of buildings. Detailed guidance on the needs of larger, more complex or specialised buildings, can be found elsewhere (see paragraphs 0.19 to 0.33).

It should also be noted that although most of the information contained in this Section is related to general issues of design, special provisions apply to the layouts of certain institutional buildings (see paragraphs 4.38 onwards).

In the case of small shop, office, industrial, storage and other similar premises (ones with no storey larger than 280m<sup>2</sup> and having no more than 2 storeys plus a basement storey), the guidance in paragraph 4.32 to 4.37 may be followed instead of the other provisions in this Section.

### Escape route design

#### Number of escape routes and exits

**4.2** The number of escape routes and exits to be provided depends on the number of occupants in the room, tier or storey in question and the limits on travel distance to the nearest exit given in Table 2.

**Note:** It is only the distance to the nearest exit that should be so limited. Any other exits may be further away than the distances in Table 2.

**4.3** In multi-storey buildings (see Section 5) more than one stair may be needed for escape, in which case every part of each storey will need to have access to more than one stair. This does not prevent areas from being in a dead-end condition provided that the alternative stair is accessible in case the first one is not usable.

**4.4** In mixed-use buildings, separate means of escape should be provided from any storeys (or parts of storeys) used for Residential or Assembly and Recreation purposes.

## Section 4

### Single escape routes and exits

**4.5** In order to avoid occupants being trapped by fire or smoke, there should be alternative escape routes from all parts of the building.

However a single route is acceptable for:

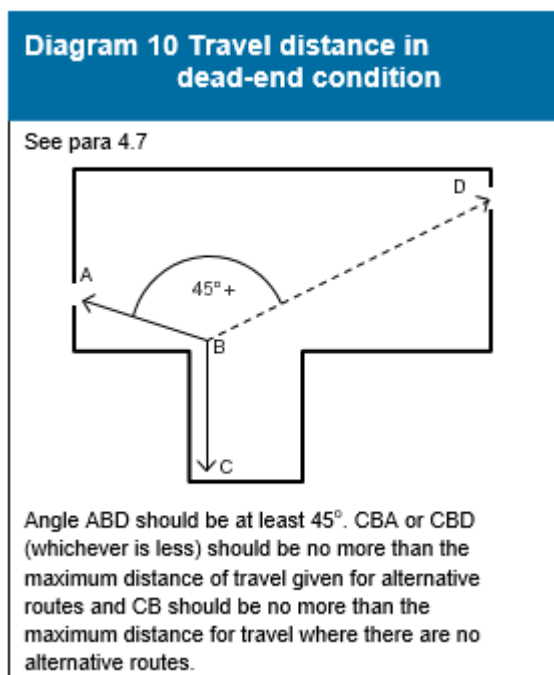
- a. parts of a floor from which a storey exit can be reached within the travel distance limit for travel in one direction set in Table 2 (see also paragraph 4.7). This is provided that, in the case of places of assembly and bars, no one room in this situation has an occupant capacity of more than 60 people or 30 people if the building is in Institutional use (Purpose Group 2a). The calculation of occupant capacity is described in Appendix C; or
- b. a storey with an occupant capacity of not more than 60 people, where the limits on travel in one direction only are satisfied (see Table 2).

**4.6** In many cases there will not be an alternative at the beginning of the route. For example, there may be only one exit from a room to a corridor, from which point escape is possible in two directions. This is acceptable provided that the overall distance to the nearest storey exit is within the limits for routes where there is an alternative and the 'one direction only' section of the route does not exceed the limit for travel where there is no alternative, see Table 2. Diagram 10 shows an example of a dead-end condition in an open storey layout.

### Access control measures

**4.7** Measures incorporated into the design of a building to restrict access to the building or parts of it should not adversely affect fire safety provisions.

Whilst it may be reasonable to secure some escape routes outside normal business hours, the measures left in place should be sufficient to allow safe evacuation of any persons left inside the building (see paragraph 6.11).



Section 4

<b>Table 2 Limitations on travel distance</b>				
			<b>Maximum travel distance<sup>(1)</sup> where travel is possible in:</b>	
<b>Purpose group</b>	<b>Use of the premises or part of the premises</b>		<b>One direction only (m)</b>	<b>More than one direction(m)</b>
2(a)	Institutional		9	18
2(b)	Other residential:			
	(a) in bedrooms <sup>(2)</sup>		9	18
	(b) in bedroom corridors		9	35
	(c) elsewhere		18	35
3	Office		18	45
4	Shop and commercial <sup>(3)</sup>		18 <sup>(4)</sup>	45
5	Assembly and recreation:			
	(a) buildings primarily for disabled people		9	18
	(b) areas with seating in rows		15	32
	(c) elsewhere		18	45
6	Industrial <sup>(5)</sup>	Normal Hazard	25	45
		Higher Hazard	12	25
7	Storage and other non-residential <sup>(5)</sup>	Normal Hazard	25	45
		Higher Hazard	12	25
2-7	Place of special fire hazard <sup>(6)</sup>		9 <sup>(7)</sup>	18 <sup>(7)</sup>
2-7	Plant room or rooftop plant:			
	(a) distance within the room		9	35
	(b) escape route not in open air (overall travel distance)		18	45
	(c) escape route in open air (overall travel distance)		60	100

**Notes:**

1. The dimensions in the Table are travel distances. If the internal layout of partitions, fittings, etc is not known when plans are deposited, direct distances may be used for assessment. The direct distance is taken as 2/3rds of the travel distance.
2. Maximum part of travel distance within the room. (This limit applies within the bedroom (and any associated dressing room, bathroom or sitting room, etc) and is measured to the door to the protected corridor serving the room or suite. Sub-item (b) applies from that point along the bedroom corridor to a storey exit.)
3. Maximum travel distances within shopping malls are given in BS 5588:Part 10. Guidance on associated smoke control measures is given in a BRE report *Design methodologies for smoke and heat exhaust ventilation* (BR 368).
4. BS 5588:Part 10 applies more restrictive provisions to units with only one exit in covered shopping complexes.



## Section 4

5. In industrial and storage buildings the appropriate travel distance depends on the level of fire hazard associated with the processes and materials being used. Higher hazard includes manufacturing, processing or storage of significant amounts of hazardous goods or materials, including: any compressed, liquefied or dissolved gas, any substance which becomes dangerous by interaction with either air or water, any liquid substance with a flash point below 65°C including whisky or other spirituous liquor, any corrosive substance, any oxidising agent, any substance liable to spontaneous combustion, any substance that changes or decomposes readily giving out heat when doing so, any combustible solid substance with a flash point less than 120° Celsius, any substance likely to spread fire by flowing from one part of a building to another.
6. Places of special fire hazard are listed in the definitions in Appendix E.
7. Maximum part of travel distance within the room/area. Travel distance outside the room/area to comply with the limits for the purpose group of the building or part.

## Number of occupants and exits

- 4.8** The figure used for the number of occupants will normally be that specified as the basis for the design. When the number of occupants likely to use a room, tier or storey is not known, the capacity should be calculated on the basis of the appropriate floor space factors. Guidance for this is set out in Appendix C.

Table 3 gives the minimum number of escape routes and exits from a room or storey according to the number of occupants. (This number is likely to be increased by the need to observe travel distances and by other practical considerations.)

The width of escape routes and exits is the subject of paragraph 4.18.

<b>Table 3 Minimum number of escape routes and exits from a room, tier or storey</b>	
<b>Maximum number of persons</b>	<b>Minimum number of escape routes/exits</b>
60	1
600	2
More than 600	3

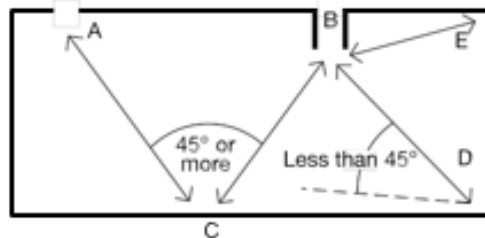
## Alternative escape routes

- 4.9** A choice of escape routes is of little value if they are all likely to be disabled simultaneously. Alternative escape routes should therefore satisfy the following criteria:
- a. they are in directions 45° or more apart (see Diagram 11); or
  - b. they are in directions less than 45° apart, but are separated from each other by fire-resisting construction.

## Section 4

### Diagram 11 Alternative escape routes

See para 4.9



Alternative routes are available from C because angle ACB is  $45^\circ$  or more and therefore CA or CB (whichever is the less) should be no more than the maximum distance for travel given for alternative routes.

Alternative routes are not available from D because angle ADB is less than  $45^\circ$  (therefore see Diagram 10). There is also no alternative route from E.

## Inner rooms

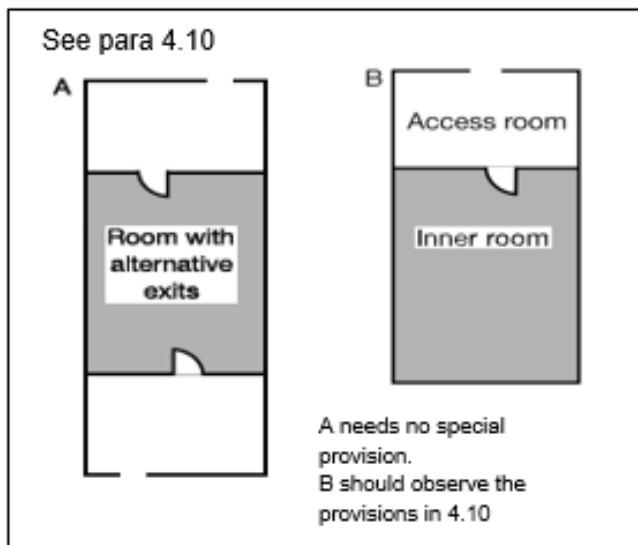
**4.10** A room from which the only escape route is through another room is called an inner room. It is at risk if a fire starts in the other room, called the access room (see Diagram 12).

Such an arrangement is only acceptable if the following conditions are satisfied:

- a. the occupant capacity of the inner room should not exceed 60 (30 in the case of a building in purpose group 2a (Institutional));
- b. the inner room should not be a bedroom;
- c. the inner room should be entered directly off the access room (but not via a corridor);
- d. the escape route from the inner room should not pass through more than one access room;
- e. the travel distance from any point in the inner room to the exit(s) from the access room should not exceed the appropriate limit given in Table 2;
- f. the access room should not be a place of special fire hazard and should be in the control of the same occupier; and
- g. one of the following arrangements should be made:
  - i. the enclosures (walls or partitions) of the inner room should be stopped at least 500mm below the ceiling; or
  - ii. a suitably sited vision panel not less than  $0.1\text{m}^2$  should be located in the door or walls of the inner room, to enable occupants of the inner room to see if a fire has started in the outer room; or
  - iii. the access room should be fitted with a suitable automatic fire detection and alarm system to warn the occupants of the inner room of the outbreak of a fire in the access room.

## Section 4

### Diagram 12 Inner room and access room



### Planning of exits in a central core

**4.11** Buildings with more than one exit in a central core should be planned so that storey exits are remote from one another and so that no two exits are approached from the same lift hall, common lobby or undivided corridor, or linked by any of these (see Diagram 13).

### Open spatial planning

**4.12** Escape routes should not be prejudiced by openings between floors, such as an escalator. (see Diagram 14).

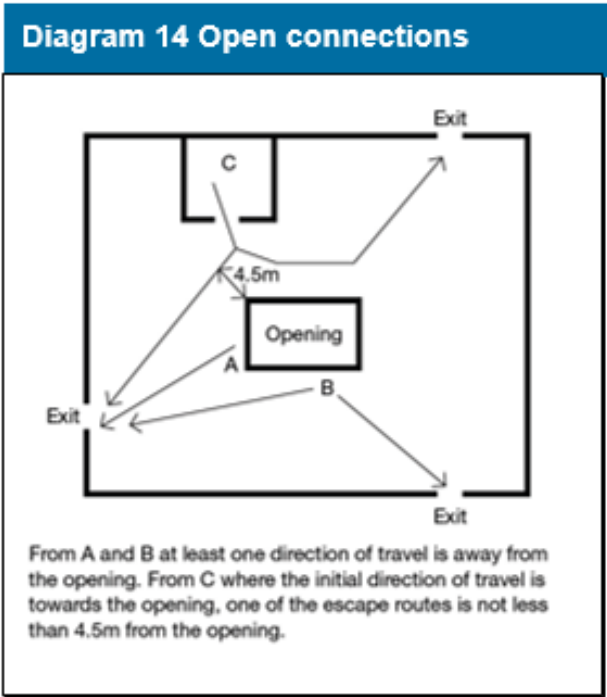
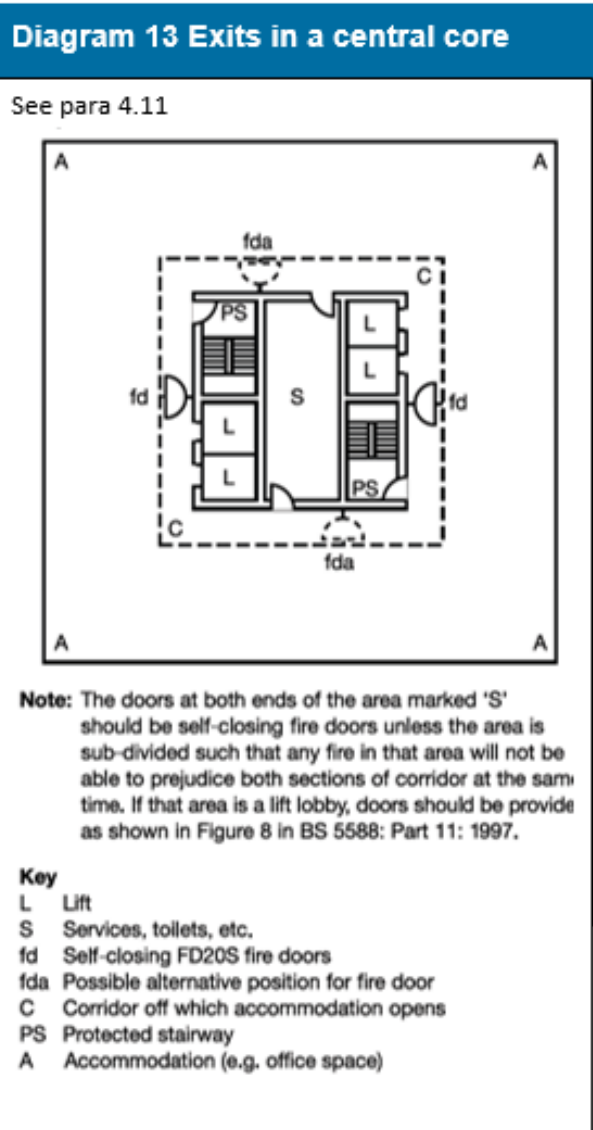
An escape route should not be within 4.5m of the openings unless:

- a. the direction of travel is away from the opening; or
- b. there is an alternative escape route which does not pass within 4.5m of the open connection.

### Access to storey exits

**4.13** Any storey which has more than one escape stair should be planned so that it is not necessary to pass through one stairway to reach another. However it would be acceptable to pass through one stairway's protected lobby to reach another stair.

Section 4



**Separation of circulation routes from stairways**

**4.14** Unless the doors to a protected stairway and any associated exit passageway are fitted with an automatic release mechanism (see Appendix B, paragraph 3b), the stairway and any associated exit passageway should not form part of the primary circulation route between different parts of the building at the same level. This is because the self-closing fire doors are more likely to be rendered ineffective as a result of their constant use, or because some occupants may regard them as an impediment. For example, the doors are likely to be wedged open or have their closers removed.

**Storeys divided into different uses**

**4.15** Where a storey contains an area (which is ancillary to the main use of the building) for the consumption of food and/or drink, then:

## Section 4

- a. not less than two escape routes should be provided from each such area (except inner rooms which meet the provisions in paragraph 4.10); and
- b. the escape routes from each such area should lead directly to a storey exit without entering any kitchen or similar area of high fire hazard.

### Storeys divided into different occupancies

**4.16** Where any storey is divided into separate occupancies (i.e. where there are separate ownerships or tenancies of different organisations):

- a. the means of escape from each occupancy should not pass through any other occupancy; and
- b. if the means of escape include a common corridor or circulation space, either it should be a protected corridor, or a suitable automatic fire detection and alarm system should be installed throughout the storey.

### Height of escape routes

**4.17** All escape routes should have a clear headroom of not less than 2m except in doorways.

### Width of escape routes and exits

**4.18** The width of escape routes and exits depends on the number of persons needing to use them. They should not be less than the dimensions given in Table 4. (Attention is also drawn to the guidance in Approved Document M Access to and Use of buildings).

**4.19** Where the maximum number of people likely to use the escape route and exit is not known, the appropriate capacity should be calculated on the basis of the occupant capacity. Guidance is set out in Appendix C.

**4.20** Guidance on the spacing of fixed seating for auditoria is given in BS 5588-6:1991.

**Table 4** Widths of escape routes and exits

Maximum number of persons	Minimum width mm <sup>(1)(2)(3)</sup>
60	750 <sup>(4)</sup>
110	850
220	1050
More than 220	5 per person <sup>(5)</sup>

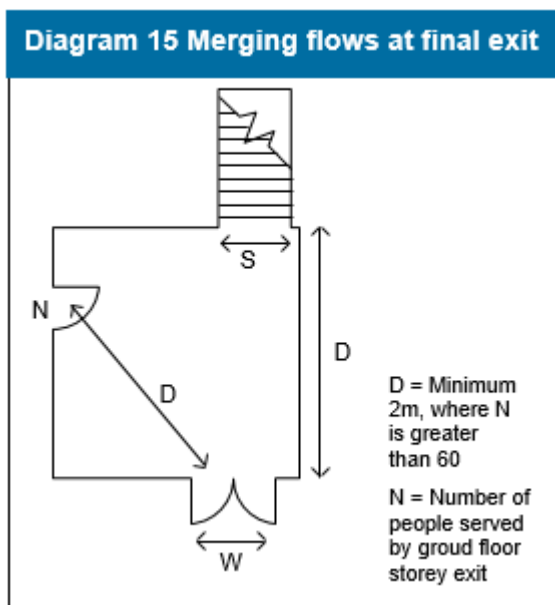
**Notes:**

1. Refer to Appendix C on methods of measurement.
2. In order to follow the guidance in the Approved Document to Part M the widths given in the table may need to be increased.
3. Widths less than 1050mm should not be interpolated.
4. May be reduced to 530mm for gangways between fixed storage racking, other than in public areas of Purpose Group 4 (shop and commercial).
5. 5mm/person does not apply to an opening serving less than 220 persons.

## Section 4

### Calculating exit capacity

- 4.21** If a storey or room has two or more storey exits it has to be assumed that a fire might prevent the occupants from using one of them. The remaining exit(s) need to be wide enough to allow all the occupants to leave quickly. Therefore when deciding on the total width of exits needed according to Table 4, the largest exit should be discounted. This may have implications for the width of stairs, because they should be at least as wide as any storey exit leading onto them. Although some stairs are not subject to discounting (see paragraphs 5.20 and 5.21), the storey exits onto them will be.
- 4.22** The total number of persons which two or more available exits (after discounting) can accommodate is found by adding the maximum number of persons that can be accommodated by each exit width. For example, 3 exits each 850mm wide will accommodate  $3 \times 110 = 330$  persons (not the 510 persons accommodated by a single exit 2550mm wide).
- 4.23** Where a ground floor storey exit shares a final exit with a stair via a ground floor lobby, the width of the final exit should be sufficient to enable a maximum evacuation flow rate equal to or greater than that from the storey exit and stair combined (see Diagram 15).



This can be calculated from the following formula:

$$W = ((N/2.5) + (60S))/80$$

Where:

W = width of final exit, in metres

N = number of people served by ground floor storey exit

S = stair width in metres

**Note:** Where the number of persons (N) entering the lobby from the ground floor is more than 60 then the distance from the foot of the stair, or the storey exit, to the final exit

## Section 4

should be a minimum of two metres (see Diagram 15). Where this cannot be achieved then the width of the final exit (W) should be no less than the width of the stair plus the width of the storey exit.

### Worked example

*A ground floor storey exit serving 250 persons shares a common final exit with a 1.2 m wide stair*

*Required final exit =  $((250/2.5) + (1.2 \times 60))/80$  width (metres) = 2.150 metres*

### Protected corridors

**4.24** A corridor which serves a part of the means of escape in any of the following circumstances should be a protected corridor:

- a. every corridor serving bedrooms;
- b. every dead-end corridor (excluding recesses and extensions not exceeding 2m deep as shown in Figures 10 and 11 of BS 5588-11:1997); and
- c. any corridor common to two or more different occupancies (see also paragraph 4.16).

### Enclosure of corridors that are not protected corridors

**4.25** Where a corridor that is used as a means of escape, but is not a protected corridor, is enclosed by partitions, those partitions provide some defence against the spread of smoke in the early stages of a fire, even though they may have no fire resistance rating. To maintain this defence the partitions should be carried up to the soffit of the structural floor above, or to a suspended ceiling and openings into rooms from the corridor should be fitted with doors, which need not be fire doors. Open planning, while offering no impediment to smoke spread, has the compensation that occupants can become aware of a fire quickly.

### Sub-division of corridors

**4.26** If a corridor provides access to alternative escape routes, there is a risk that smoke will spread along it and make both routes impassable before all occupants have escaped.

To avoid this, every corridor more than 12m long which connects two or more storey exits, should be sub-divided by self-closing fire doors (and any necessary associated screens). The fire door(s) and any associated screen(s) should be positioned approximately mid-way between the two storey exits to effectively safeguard the route from smoke (having regard to the layout of the corridor and to any adjacent fire risks).

In a building of Purpose Groups 2 to 7, where a cavity exists above the enclosures to any such corridor, because the enclosures are not carried to full storey height or (in the case of a top storey) to the underside of the roof covering, the potential for smoke to bypass the sub-division should be restricted by:

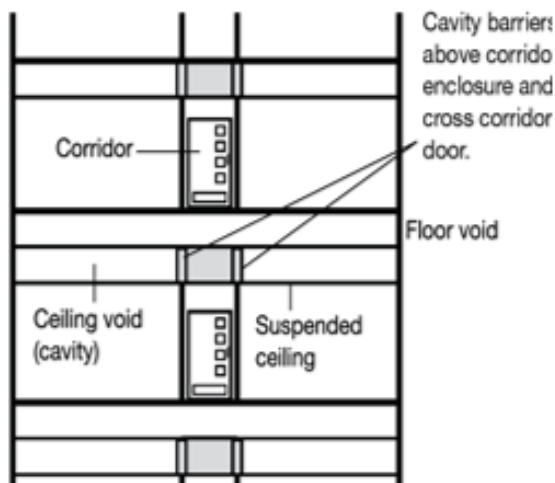
**Section 4**

- a. fitting cavity barriers on the line of the enclosure(s) to and across the corridor (see Diagram 16a); or
- b. sub-dividing the storey using fire-resisting construction passing through the line of the sub-division of the corridor (see diagram 16b). Any void above this subdivision should be fitted with cavity barriers on the line of sub-division of the storey and the corridor; or
- c. enclosing the cavity on the lower side by a fire-resisting ceiling which extends throughout the building, compartment or separated part.

Any door which could provide a path for smoke to bypass the sub-division should be made self closing (but need not necessarily be fire-resisting).

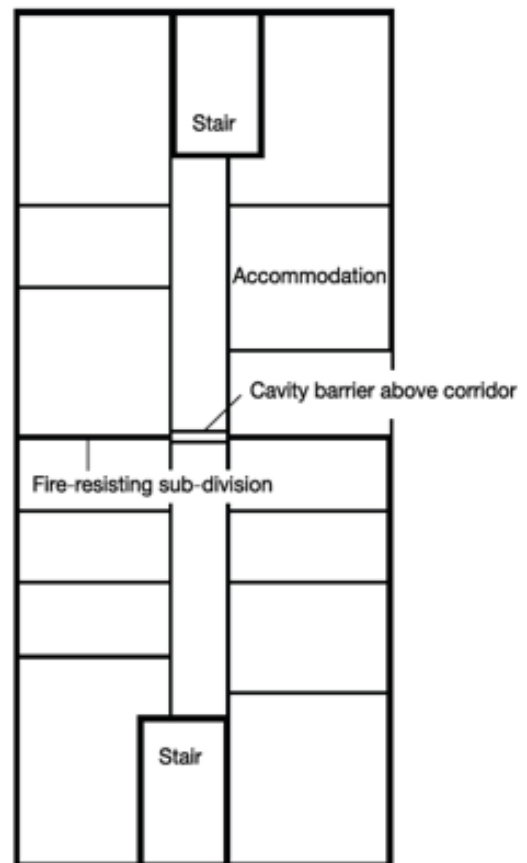
**Diagram 16 Subdivision of corridors**

**a. SECTION TO SHOW USE OF CAVITY BARRIERS ABOVE THE CORRIDOR ENCLOSURE**  
see paragraph 4.26 a.



Where the corridor is a protected escape route, cavity barriers may also be required in any floor void beneath the corridor enclosure (see paragraph 10.4)

**b. PLAN SHOWING SUB-DIVISION OF THE STOREY BY FIRE-RESISTING CONSTRUCTION**  
See paragraph 4.26 b



The sub-division should be carried full storey height and includes sub-division of the corridor. A cavity barrier may be used in any ceiling void over the sub-division.



## Section 4

- 4.27** If a dead-end portion of a corridor provides access to a point from which alternative escape routes are available, there is a risk that smoke from a fire could make both routes impassable before the occupants in the dead-end have escaped.

To avoid this, unless the escape stairway(s) and corridors are protected by a pressurization system complying with BS EN 12101-6:2005, every dead-end corridor exceeding 4.5m in length should be separated by self-closing fire doors (together with any necessary associated screens) from any part of the corridor which:

- a. provides two directions of escape (see Diagram 17(a)); or
- b. continues past one storey exit to another (see Diagram 17(b)).

### Cavity barriers

- 4.28** Additional measures to safeguard escape routes from smoke are given in Section 10 (B3).

### External escape routes

- 4.29** Guidance on the use of external escape stairs from buildings is given in paragraph 5.44.

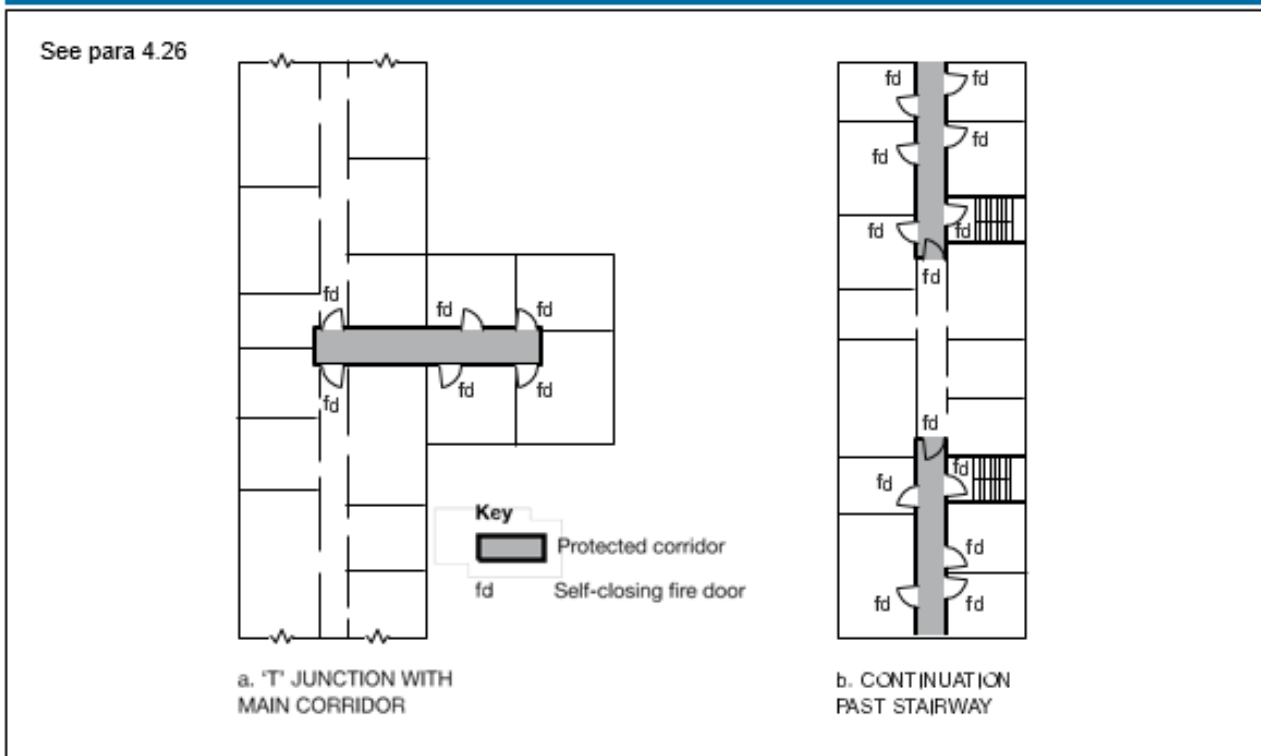
- 4.30** Where an external escape route (other than a stair) is beside an external wall of the building, that part of the external wall within 1800mm of the escape route should be of fire-resisting construction, up to a height of 1100mm above the paving level of the route. For guidance on external escape stairs see paragraph 6.25.

### Escape over flat roofs

- 4.31** If more than one escape route is available from a storey, or part of a building, one of those routes may be by way of a flat roof, provided that:
- a. the route does not serve an Institutional building, or part of a building intended for use by members of the public; and
  - b. it meets the provisions in paragraph 6.35.

Section 4

**Diagram 17 Dead-end corridors**



**Small premises**

**4.32** In small premises, as described in paragraph 4.33, the number of persons is generally limited and the size of the premises, when undivided, will tend to enable clear vision of all parts. Therefore the occupants will be able to quickly reach an entrance/exit in an emergency. Thus a reduction in the number of exits and stairs as set out in paragraphs 4.33 to 4.37, 5.6 and 5.33 is acceptable. However, where the sale, storage or use of highly flammable materials is involved, it is necessary for persons to rapidly vacate the premises in the event of a fire. To facilitate this, the general guidance in paragraph 4.33 would not apply.

**General**

**4.33** The following paragraphs apply in place of only those provisions relating to the number and positioning of exits and protected stairways and measurement of distances of travel.

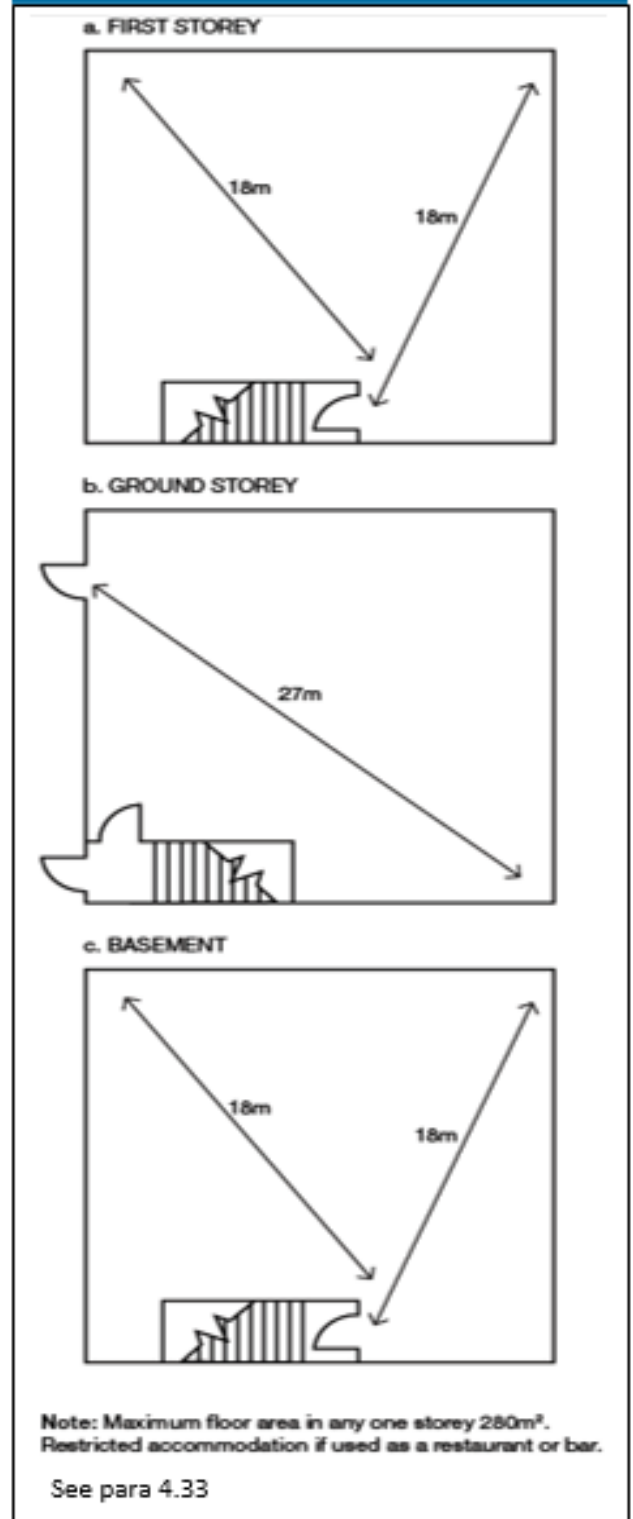
**Note 1:** They do not apply to premises used principally for the storage and/or sale of highly flammable liquids or materials.

**Note 2:** In covered shopping complexes, the size of small units that may be of small units that may be served by a single exit is further restricted. This is dealt with in BS 5588-10:1991.

## Section 4

- a. The premises should be in a single occupancy and should not comprise more than a basement, a ground floor and a first storey. No storey should have a floor area greater than  $280\text{m}^2$  (see Diagram 18);
- b. Any kitchen or other open cooking arrangement should be sited at the extremity of any dead end remote from the exit(s); and
- c. The planned seating accommodation or the assessed standing accommodation (see Table C1) for small premises comprising a bar or restaurant should not exceed 30 persons per storey. This figure may be increased to 100 persons for the ground storey if that storey has an independent final exit.

### Diagram 18 Maximum travel distances in a small two or three storey premises with a single protected stair to each storey



Section 4

## Construction

**4.34** The floor areas should be generally undivided (except for kitchens, ancillary offices and stores) to ensure that exits are clearly visible from all parts of the floor areas.

**4.35** Store rooms should be enclosed with fire-resisting construction.

**4.36** Sufficient clear glazed areas should be provided in any partitioning separating a kitchen or ancillary office from the open floor area to enable any person within the kitchen or office to obtain early visual warning of an outbreak of fire. Alternatively, an automatic fire detection and alarm system may be provided in the outer room.

**Note:** The clear glazed area or vision panel may need to be provided for other reasons.

## Distance of travel and number of escape routes

**4.37** The escape routes from any storey should be of such a number and so situated that the distance of travel from any point to the nearest storey exit does not exceed the appropriate limits set out in Table 5.

**Note:** The distance of travel in small premises with an open stairway is measured to the foot of the stair in a basement or to the head of the stair in a first storey see paragraph 5.33.

The siting of two or more exits or stairs should be such that they afford effective alternative directions of travel from any relevant point in a storey.

Table 5 Maximum distances of travel in small premises with a protected stair	
Storey	Maximum Travel Distance
Ground storey with a single exit	27
Basement or first storey with a single stair	18
Storey with more than one exit/stair	45

**Note:**

The dimensions in the Table are travel distances. If the internal layout of partitions, fittings, etc is not known when plans are deposited, direct distances may be used for assessment. The direct distance is taken as 2/3rds of the travel distance.

## Section 4

### Residential care homes

#### General

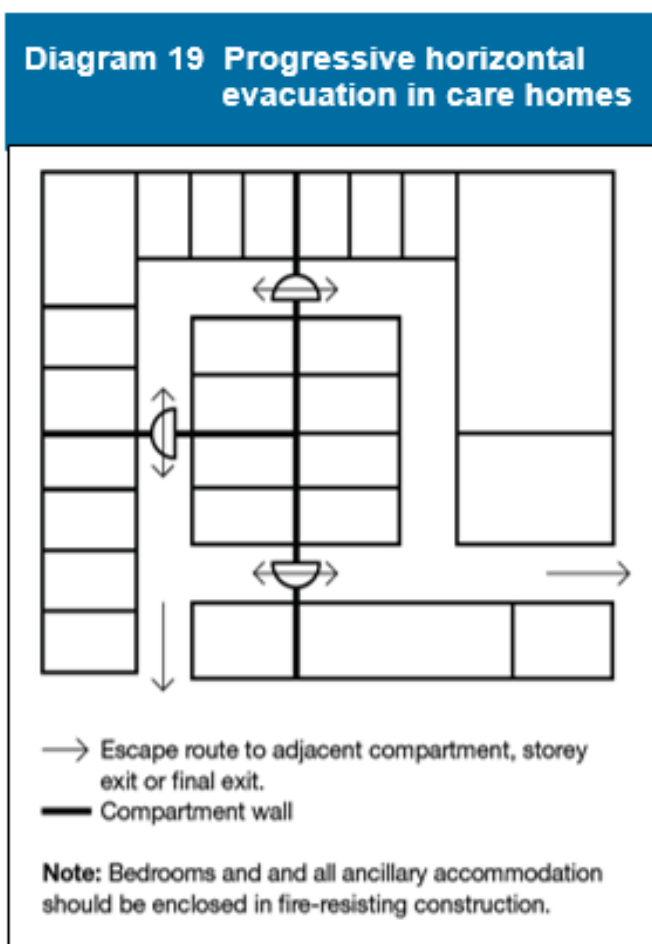
- 4.38** Residential care homes are quite diverse and can be used by a variety of residents, often requiring different types of care to suit their specific needs. They can include homes for the elderly, children and people who are physically or mentally disabled. The choice of fire safety strategy is dependent upon the way a building is designed, furnished, staffed and managed and the level of dependency of the residents.
- 4.39** Generally, in care homes for the elderly it is reasonable to assume that at least a proportion of the residents will need some assistance to evacuate. As such these buildings should be designed for progressive horizontal evacuation (PHE) in accordance with paragraphs 4.41 to 4.52 below. For other types of care home a judgement should be made as to whether PHE or a simultaneous evacuation strategy is appropriate. Whatever approach is adopted in the design of a building this must be recorded and communicated to the building management to ensure that procedures are adopted that are compatible with the building design.
- 4.40** The guidance on PHE given in paragraphs 4.41 to 4.52 is for those care homes, to which the provisions of the “*Firecode*” documents are no applicable (see Para 0.21).

#### Planning for progressive horizontal evacuation

- 4.41** The concept of PHE requires those areas used for the care of residents to be subdivided into protected areas separated by compartment walls and compartment floors. This allows horizontal escape to be made by evacuating into adjoining protected areas. The objective is to provide a place of relative safety within a short distance, from which further evacuation can be made if necessary but under less pressure of time.
- 4.42** Each storey, used for the care of residents, should be divided into at least three protected areas by compartment walls and all floors should be compartment floors.
- 4.43** Every protected area should be provided with at least two exits to adjoining, but separate protected areas. Travel distances within a protected area to these exits should not exceed those given in Table 2. The maximum travel distance from any point should be not more than 64m to a storey exit or a final exit.
- 4.44** A fire in any one protected area should not prevent the occupants of any other area from reaching a final exit (see Diagram 19). Escape routes should not pass through ancillary accommodation such as that listed in paragraph 4.50.
- 4.45** The number of residents’ beds in protected areas should be established based on assessment of the number of staff likely to be available and the level of assistance that residents may require. In no case should this exceed 10 beds in any one protected area.

## Section 4

- 4.46** Adjoining protected areas into which horizontal evacuation may take place should each have a floor area sufficient to accommodate not only their own occupants but also the occupants from the largest adjoining protected area.



### Fire detection

- 4.47** A fire detection and alarm system should be provided to an L1 standard in accordance with BS 5839-1:2002.

### Bedrooms

- 4.48** Each bedroom should be enclosed in fire-resisting construction with fire resisting doors, and every corridor serving bedrooms should be a protected corridor (see paragraph 4.24).
- 4.49** Bedrooms should not contain more than one bed (this includes a double bed).

### Ancillary accommodation

- 4.50** Ancillary accommodation such as the following, should be enclosed by fire-resisting construction.

## Section 4

- |   |                     |
|---|---------------------|
| a. chemical stores;                     | b. cleaners' rooms; |
| c. clothes' storage;                    | d. day rooms;       |
| e. smoking rooms;                       | f. disposal rooms;  |
| g. plant rooms;                         | h. linen stores;    |
| i. kitchens;                            | j. laundry rooms;   |
| k. staff changing and locker rooms; and | l. store rooms.     |

### Door-closing devices

**4.51** The specification of door-closing devices for fire doors should take account of the needs of residents. In particular where self-closing doors could present an obstacle to the residents of the building then the following hardware in accordance with BS EN 1155:1997 would be appropriate;

Bedrooms – free-swing door closers.

Circulation spaces – hold-open devices.

### Automatic fire suppression systems

**4.52** Care homes shall comply with Section 2. Where an automatic fire suppression system is provided in accordance with section 2, the following variations to the guidance given in paragraphs 4.41 to 4.51 are acceptable,

- a. Fire doors to bedrooms need not be fitted with self-closing devices.
- b. Protected areas may contain more than 10 beds.
- c. Bedrooms may contain more than one bed.

**Note:** Management procedures will need to take account of the larger number of residents that may need assistance and the need to manually close bedroom doors during sleeping hours.

## Section 5

## B1

# Design for vertical escape – buildings other than flats

### Introduction

**5.1** An important aspect of means of escape in multi-storey buildings is the availability of a sufficient number of adequately sized and protected escape stairs. This Section deals with escape stairs and includes measures necessary to protect them in all types of building.

The limitation of distances of horizontal travel for means of escape purposes means that most people should be able independently to reach the safety of a protected escape route or final exit. However, some people, for example those who use wheelchairs, may not be able to use stairways without assistance. For them evacuation involving the use of refuges on escape routes and either assistance down (or up) stairways, or the use of suitable lifts, will be necessary.

This Section should be read in conjunction with the general provisions in Section 6.

### Number of escape stairs

**5.2** The number of escape stairs needed in a building (or part of a building) will be determined by:

- a. the constraints imposed in Section 4 on the design of horizontal escape routes;
- b. whether independent stairs are required in mixed occupancy buildings (see paragraph 5.4);
- c. whether a single stair is acceptable (see paragraphs 5.5 and 5.6); and
- d. provision of adequate width for escape (see paragraph 5.15) while allowing for the possibility that a stair may have to be discounted because of fire or smoke (see paragraph 5.20).

**5.3** In larger buildings, provisions for access for the Fire and Rescue Service may apply, in which case, some escape stairs may also need to serve as firefighting stairs. The number of escape stairs may therefore be affected by provisions made in Section 18, paragraphs 18.8 and 18.9.

### Mixed use buildings

**5.4** Where a building contains storeys (or parts of storeys) in different purpose groups, it is important to consider the effect of one risk on another. A fire in a shop, or unattended office, could have serious consequences on, for example, a residential or hotel use in the same building. It is therefore important to consider whether completely separate routes of escape should be provided from each different use within the building or whether other effective means to protect common escape routes can be provided.



## Section 5

### Single escape stairs

**5.5** Provided that independent escape routes are not necessary from areas in different purpose groups in accordance with paragraph 3.50 or 5.4, the situations where a building (or part of a building) may be served by a single escape stair are:

- a. from a basement which is allowed to have a single escape route in accordance with paragraph 4.5b and Table 2;
- b. from a building (other than small premises, see 5.5c) which has no storey with a floor level more than 11m above ground level and in which every storey is allowed to have a single escape route in accordance with paragraph 4.5b and Table 2;
- c. in the case of small premises (see paragraph 4.32), in situations where the guidance in paragraph 5.6 is followed.

### Single escape stairs in small premises

**5.6** A single escape stair may be used from:

- a. small premises as described in paragraph 4.33;
- b. an office building comprising not more than five storeys above the ground storey, provided that:
  - i. the travel distance from every point in each storey does not exceed that given in Table 2 for escape in one direction only; and
  - ii. every storey at a height greater than 11m has an alternative means of escape;
- c. a factory comprising not more than:
  - i. two storeys above the ground storey (if the building, or part of the building, is of low risk); or
  - ii. one storey above the ground storey (if the building, or part of the building, is of normal risk); provided that the travel distance from every point on each storey does not exceed that given in Table 2 for escape in one direction only; or
- d. process plant buildings with an occupant capacity of not more than 10.

### Provision of refuges

**5.7** Refuges are relatively safe waiting areas for short periods. They are not areas where disabled people should be left alone indefinitely until rescued by the fire and rescue service, or until the fire is extinguished.

A refuge should be provided for each protected stairway affording egress from each storey, except storeys consisting exclusively of plant rooms.

**Note:** Whilst a refuge should be provided for each stairway, they need not necessarily be located within the stair enclosure but should enable direct access to the stair. The number of refuge spaces need not necessarily equal the sum of the number of wheelchair users who can be present in the building. Refuges form a part of the management plan and it may be that more than one disabled person will use a single refuge as they pass through as a part of the evacuation procedure.

## Section 5

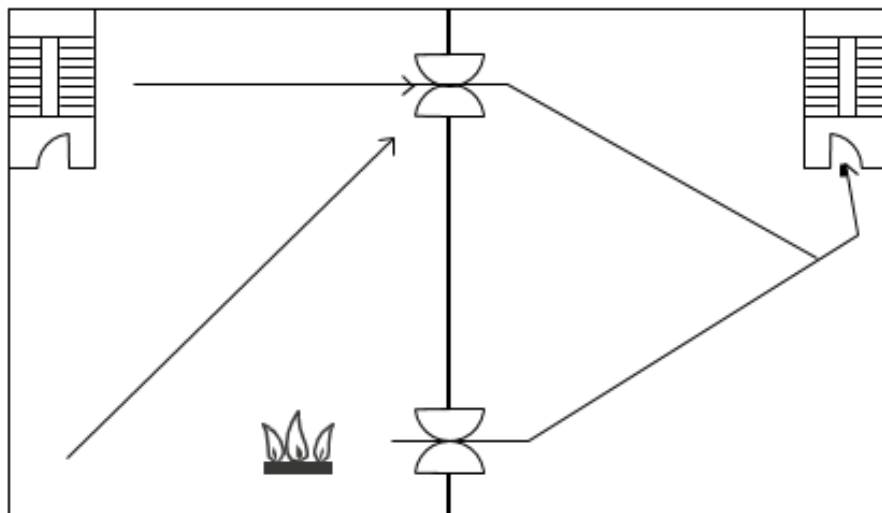
**5.8** The following are examples of satisfactory refuges:

- a. an enclosure such as a compartment (see Diagram 20), protected lobby, protected corridor or protected stairway (see Diagram 21); and
- b. an area in the open air such as a flat roof, balcony, podium or similar place which is sufficiently protected (or remote) from any fire risk and provided with its own means of escape.

**5.9** Each refuge should provide an area accessible to a wheelchair of at least 900mm x 1400mm in which a wheelchair user can await assistance. Where a refuge is a protected stairway or protected lobby or protected corridor, the wheelchair space should not reduce the width of the escape route. Where the wheelchair space is within a protected stairway, access to the wheelchair space should not obstruct the flow of persons escaping.

**Diagram 20 Refuge formed by compartmentation**

See para 5.8



Storey divided into two refuges by compartment wall (stairways not provided with wheelchair space).

**Note:** Persons occupying the left-hand compartment would not reach a refuge until they had entered the right-hand compartment. Two doorsets in the partition are necessary in case access to one of the doorsets is blocked by fire.

## Section 5



- 5.10** Refuges and evacuation lifts should be clearly identified by appropriate fire safety signs. Where a refuge is in a lobby or stairway the sign should be accompanied by a blue mandatory sign worded “Refuge – keep clear”.

### Communication

- 5.11** To facilitate the effective evacuation of people from refuges an emergency voice communication (EVC) system should be provided. It is essential that the occupants of each refuge are able to alert other people that they are in need of assistance and for them to be reassured that this assistance will be forthcoming.
- 5.12** The EVC system should comply with BS5839-9:2003 and consist of Type B outstations which communicate with a master station located in the building control room (where one exists) or adjacent to the fire alarm panel.
- 5.13** In some buildings it may be more appropriate to use an alternative approach such as the use of wireless technology.

### Evacuation lifts

- 5.14** Guidance on the use of lifts when there is a fire is given in paragraph 6.39.

## Section 5

### Width of escape stairs

**5.15** The width of escape stairs should:

- a. be not less than the width(s) required for any exit(s) affording access to them;
- b. conform with the minimum widths given in Table 6;
- c. not exceed 1400mm if their vertical extent is more than 30m, unless it is provided with a central handrail (see Notes 1 and 2); and
- d. not reduce in width at any point on the way to a final exit.

**Note 1:** The 1400mm width has been given for stairs in tall buildings because research indicates that people prefer to stay within reach of a handrail when making a prolonged descent, so much so that the centre part of a wider stair is little used and could be hazardous. Thus additional stair(s) may be needed.

**Note 2:** Where a stair wider than 1400mm is provided with a central handrail, then the stair width on each side of the central handrail needs to be considered separately for the purpose of assessing stair capacity.

**5.16** If the resultant width of the stair is more than 1800mm, then for reasons of safety in use the guidance in Approved Document K *Protection from falling, collision and impact* is that, in public buildings, the stair should have a central handrail. In such a case see Note 2 to paragraph 5.15.

**5.17** Where an exit route from a stair also forms the escape from the ground and/or basement storeys, the width may need to be increased accordingly. (See paragraph 4.23).

### Calculation of minimum stair width

#### General

**5.18** Every escape stair should be wide enough to accommodate the number of persons needing to use it in an emergency. This width will depend on the number of stairs provided and whether the escape strategy for the building (or part of the building) is based on simultaneous evacuation see (paragraph 5.22) or phased evacuation see (paragraph 5.26).

**5.19** As with the design of horizontal escape routes, where the maximum number of people needing to use the escape stairs is not known, the occupant capacity should be calculated on the basis of the appropriate floor space factors. Guidance for this is set out in Appendix C.

Section 5

<b>Table 6 Minimum widths of escape stairs</b>		
<b>Situation of stair</b>	<b>Maximum number of people served <sup>(1)</sup></b>	<b>Minimum stair width (mm)</b>
1a. In an institutional building (unless the stair will only be used by staff)	150	1000 <sup>(2)</sup>
1b. In an assembly building and serving an area used for assembly purposes (unless the area is less than 100m <sup>2</sup> )	220	1100
1c. In any other building and serving an area with an occupancy of more than 50	Over 220	See Note <sup>(3)</sup>
2. Any stair not described above	50	800 <sup>(4)</sup>

**Notes:**

1. Assessed as likely to use the stair in a fire emergency.
2. BS 5588-5 recommends that firefighting stairs should be at least 1100mm wide.
3. See Table 7 for sizing stairs for simultaneous evacuation, and Table 8 for phased evacuation.
4. In order to comply with the guidance in the Approved Document to Part M on minimum widths for areas accessible to disabled people, this may need to be increased to 1000mm.

### Discounting of stairs

**5.20** Whether phased or simultaneous evacuation is used, where two or more stairs are provided it should be assumed that one of them might not be available due to fire. It is therefore necessary to discount each stair in turn in order to ensure that the capacity of the remaining stair(s) is adequate for the number of persons needing to escape. The stair discounting rule applies to a building fitted with an automatic fire suppression system.

**5.21** Two exceptions to the above discounting rules are if the escape stairs:

- a. are protected by a smoke control system designed in accordance with BS EN 12101-6:2005.
- b. are approached on each storey through a protected lobby (a protected lobby need not be provided on the topmost storey for the exception still to apply).

**Note:** Paragraph 5.34 identifies several cases where stairs need lobby protection. In such cases the likelihood of a stair not being available is significantly reduced and it is not necessary to discount a stair. However, a storey exit still needs to be discounted, see paragraph 4.21. See also paragraph 5.27 for additional guidance on the potential need to discount stairs in tall buildings utilising phased evacuation.

Section 5

## Simultaneous evacuation

**5.22** In a building designed for simultaneous evacuation, the escape stairs (in conjunction with the rest of the means of escape) should have the capacity to allow all floors to be evacuated simultaneously. In calculating the width of the stairs account is taken of the number of people temporarily housed in the stairways during the evacuation.

**5.23** Escape based on simultaneous evacuation should be used for:

- a. all stairs serving basements;
- b. all stairs serving buildings with open spatial planning; and
- c. all stairs serving Other Residential or Assembly and Recreation buildings.

**Note:** BS 5588-7:1997 includes designs based on simultaneous evacuation.

**Table 7 Capacity of a stair for basements and for simultaneous evacuation of the building**

No. of floors served	Maximum number of persons served by a stair of width:								
	1000mm	1100mm	1200mm	1300mm	1400mm	1500mm	1600mm	1700mm	1800mm
1.	150	220	240	260	280	300	320	340	360
2.	190	260	285	310	335	360	385	410	435
3.	230	300	330	360	390	420	450	480	510
4.	270	340	375	410	445	480	515	550	585
5.	310	380	420	460	500	540	580	620	660
6.	350	420	465	510	555	600	645	690	735
7.	390	460	510	560	610	660	710	760	810
8.	430	500	555	610	665	720	775	830	885
9.	470	540	600	660	720	780	840	900	960
10.	510	580	645	710	775	840	905	970	1035

**Notes:**

- 1 The capacity of stairs serving more than 10 storeys may be obtained by using linear extrapolation.
2. The capacity of stairs not less than 1100mm wide may also be obtained by using the formula in paragraph 5.25.
3. Stairs with a rise of more than 30m should not be wider than 1400mm unless provided with a central handrail (see paragraph 5.15).
4. Stairs wider than 1800mm should be provided with a central handrail (see paragraph 5.16).

## Section 5

**5.24** Where simultaneous evacuation is to be used, the capacity of stairs of widths from 1000 to 1800mm is given in Table 7.

**5.25** As an alternative to using Table 7, the capacity of stairs 1100mm or wider (for simultaneous evacuation) can be derived from the formula:

$$P = 200w + 50(w - 0.3)(n - 1), \text{ or}$$
$$w = \frac{P + 15n - 15}{150 + 50n}$$

where:

(P) is the number of people that can be served; (w) is the width of the stair, in metres; and (n) is the number of storeys served.

**Note 1:** Stairs with a rise of more than 30m should not be wider than 1400mm unless provided with a central handrail (see paragraph 5.15).

**Note 2:** Separate calculations should be made for stairs/flights serving basement storeys and those serving upper storeys.

**Note 3:** The population 'P' should be divided by the number of available stairs.

**Note 4:** The formula is particularly useful when determining the width of stairs serving a building (or part of a building) where the occupants are not distributed evenly – either within a storey or between storeys.

**Note 5:** In the formula, the first part [200w] represents the number of persons estimated to have left the stair after 2.5 minutes of evacuation. The second part [50(w-0.3)(n-1)] represents the number of persons estimated to be accommodated on the stair after this time.

### Worked examples:

*A 14-storey building comprises 12 storeys of offices (ground + 11) with the top two storeys containing flats served by separate stairs. What is the minimum width needed for the stairs serving the office floors with a population of 1200 people (excluding the ground floor population which does not use the stairs), using simultaneous evacuation? Two stairs satisfy the travel distance limitations.*

#### a. The population is distributed evenly.

*As the top office storey is at a height greater than 18m, both stairs need lobby protection (see paragraph 5.34). Therefore, as both stairs are entered at each level via a protected lobby, then both stairs can be assumed to be available (see paragraph 5.21).*

$$P = 1200/2 = 600, n = 11$$

*From the formula:*

$$600 = 200w + 50(w - 0.3)(11 - 1)$$

$$600 = 200w + (50w - 15)(10)$$

$$600 = 200w + 500w - 150$$

$$750 = 700w$$

$$w = 1070\text{mm}$$

## Section 5

*Therefore both stairs should be at least 1070mm wide. But this needs to be increased to 1100mm as the formula applies to stairs 1100mm or wider (see paragraph 5.25).*

*This width will also be adequate when one storey exit is discounted in accordance with paragraph 4.21 and the need to comply with paragraph 5.15(a) (i.e. the stair widths are not less than the minimum widths needed for 110 persons in Table 4).*

### **b. The population is not distributed evenly**

*(e.g. 1000 people occupy floors 1 to 9 and 200 occupy floors 10 and 11).*

*As the top office storey is at a height greater than 18m, both stairs need lobby protection (see paragraph 5.34). As both stairs are entered at each level via a protected lobby, then both stairs can be assumed to be available (see paragraph 5.21).*

*To find the width of the stairs serving floors 10 and 11:*

$$P = 200/2 = 100, n = 2$$

*From the formula:*

$$100 = 200w + 50(w - 0.3)(2 - 1)$$

$$100 = 200w + (50w - 15)(1)$$

$$100 = 200w + 50w - 15$$

$$115 = 250w \quad w = 460\text{mm}$$

*Therefore both stairs between the 9th floor landing and the top floor should be at least 460mm. But this needs to be increased to 1100mm as the formula applies to stairs 1100mm or wider (see paragraph 5.25).*

*This width will also be adequate when one storey exit is discounted in accordance with paragraph 4.21 and the need to comply with paragraph 5.15(a) (i.e. the stair widths are not less than the minimum widths needed for 100 persons in Table 4).*

*the stairs serving floors 1 to 9:*

$$P = 1200/2 = 600, n = 9$$

*From the formula:*

$$600 = 200w + 50(w - 0.3)(9 - 1)$$

$$600 = 200w + (50w - 15)(8)$$

$$600 = 200w + 400w - 120$$

$$720 = 600w$$

$$w = 1200\text{mm}$$

*Therefore both stairs between the 9th floor landing and the ground floor should be at least 1200mm wide.*



## Section 5

*This width will also be adequate when one storey exit is discounted in accordance with paragraph 3.21 and the need to comply with paragraph 5.15(a) (i.e. the stair widths are not less than the minimum widths needed for 111 persons in Table 4.*

### Phased evacuation

- 5.26** Where it is appropriate to do so, it may be advantageous to design stairs in high buildings on the basis of phased evacuation. In phased evacuation the first people to be evacuated are all those of reduced mobility and those on the storey most immediately affected by the fire. Subsequently, if there is a need to evacuate one people, it is done two floors at a time. It is a method which cannot be used in every type of building and it depends on the provision (and maintenance) of certain supporting facilities such as fire alarms. It does however enable narrower stairs to be incorporated than would be the case if simultaneous evacuation were used and has the practical advantage of reducing disruption in large buildings.
- 5.27** In tall buildings over 30m in height, where phased evacuation is adopted, there is a potential that persons attempting to escape could be impeded by firefighters entering and operating within the building. This potential varies with the height of the building and with the number of escape stairs that are available. Generally, this can be addressed by incorporating special management procedures into the evacuation strategy in consultation with Fire and Rescue Service. However, in some very tall buildings, typically those over 45m in height, physical measures may need to be incorporated into the building (e.g. by discounting a stair or by some other suitable means).
- 5.28** Phased evacuation may be used for any building provided it is not identified in paragraph 5.23 as needing simultaneous evacuation.
- 5.29** The following criteria should be satisfied in a building (or part of a building) that is designed on the basis of phased evacuation:
- the stairways should be approached through a protected lobby or protected corridor at each storey, except a top storey;
  - the lifts should be approached through a protected lobby at each storey (see paragraph 6.42);
  - every floor should be a compartment floor;
  - if the building has a storey with a floor over 30m above ground level, the building should be protected throughout by an automatic fire suppression system in accordance with section 2.
  - the building should be fitted with an appropriate fire warning system, conforming to at least the L3 standard given in BS 5839-1:2002; and
  - an internal speech communication system should be provided to permit conversation between a control point at fire and rescue service access level and a fire warden on every storey. In addition, the recommendations relating to phased evacuation provided in BS 5839-1 should be followed. Where it is deemed appropriate to install a voice alarm this should be in accordance with BS 5839-8: 1998.

**Section 5**

**5.30** The minimum width of stair needed when phased evacuation is used is given in Table 8. This table assumes a phased evacuation of the fire floor first followed by evacuation of not more than two floors at a time.

<b>Table 8 Minimum width of stairs designed for phased evacuation</b>	
<b>Maximum number of people in any storey</b>	<b>Stair width mm (1)</b>
100	1000
120	1100
130	1200
140	1300
150	1400
160	1500
170	1600
180	1700
190	1800

**Notes:**

1. Stairs with a rise of more than 30m should not be wider than 1400mm unless provided with a central handrail (see paragraph 6.6).
2. As an alternative to using this table, provided that the minimum width of a stair is at least 1000mm, the width may be calculated from:  $[(P \times 10) - 100]$ mm where P = the number of people on the most heavily occupied storey.

**Worked example using Table 8**

*What is the minimum width needed for the stairs serving an 15-storey office building (ground + 14 office floors) assuming a total population of 2500 people (excluding the ground floor population which does not use the stairs). Three stairs satisfy the travel distance limitations.*

*The building is over 45 metres in height and designed for phased evacuation. It has been decided to discount one stair to take account of fire and rescue service operations as described in paragraphs 5.27. Therefore:*

*Number of persons per storey =  $2500/14 = 179$ ;*

*Each remaining stair must be able to accommodate half the population of one storey (i.e. 90 persons).*

*Thus each stair requires a width of 1000mm (maximum capacity 100 persons).*

*This width will also be adequate when one storey exit is discounted in accordance with paragraph 4.21 and the need to comply with paragraph 5.15(a) (i.e. the stair widths are*

## Section 5

*not less than the minimum width needed for 90 persons in Table 4).*

*At least one of those stairs will need to be a firefighting stair thus a minimum width of 1100mm will be needed (see note 2 to Table 7).*

### Additional worked example using Table 8

*What is the minimum width needed for the stairs serving a 9-storey office building (ground + 8 office floors) assuming a total population of 1920 people (excluding the ground floor population which does not use the stairs). Two stairs satisfy the travel distance limitations.*

*As both stairs need to be entered at each level by a protected lobby (see paragraph 5.29), then both stairs can be assumed to be available (see paragraph 5.21). Therefore:*

*Number of persons per storey =  $1920/8 = 240$ ;*

*Each stair must be able to accommodate half the population of one storey (i.e.  $240/2 = 120$  persons)*

*Thus both stairs would require a width of 1100mm (maximum capacity 120 persons) according to Table 8, but:*

*Each storey exit needs to be able to serve 240 persons due to discounting, in accordance with paragraph 4.21. The minimum exit width needed for 240 persons in Table 4 is 1200mm. In accordance with paragraph 5.15(a) the stair width should be at least as wide as the storey exit serving it.*

*The required stair width is therefore 1200mm.*

## Protection of escape stairs

### General

**5.31** Escape stairs need to have a satisfactory standard of fire protection if they are to fulfill their role as areas of relative safety during a fire evacuation. The guidance in paragraphs 5.32 to paragraph 5.33 should be followed to achieve this.

### Enclosure of escape stairs

**5.32** Every internal escape stair should be a protected stairway (i.e. it should be within a fire-resisting enclosure).

However an unprotected stair (e.g. an accommodation stair) may form part of an internal route to a storey exit or final exit, provided that the distance of travel and the number of people involved are very limited. For example, small premises (described in paragraph 4.32, 5.6 and 5.33) and raised storage areas (see paragraphs 8.7 and 8.8).

There may be additional measures if the protected stairway is also a protected shaft (where it penetrates one or more compartment floors, see Section 9) or if it is a firefighting shaft (see Section 18).

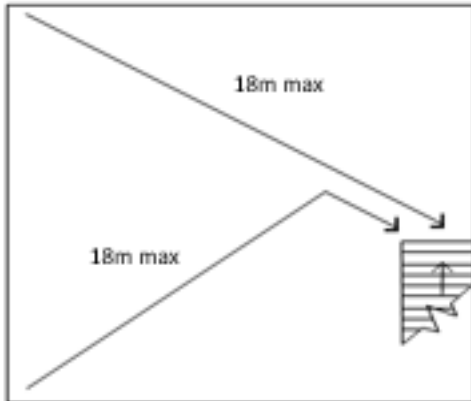
## Section 5

### Small Premises

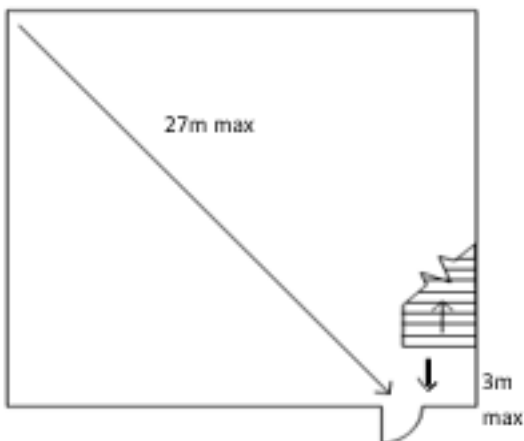
- 5.33** A stair in a small premises, which is not a bar or restaurant, may be open if it does not connect more than two storeys and delivers into the ground storey not more than 3m from the final exit (see Diagrams 22 and 23) and either:
- a. the storey is also served by a protected stairway; or
  - b. it is a single stair in a small premises with the floor area in any storey not exceeding 90m<sup>2</sup> and, if the premises contains three storeys, the stair serving either the top or bottom storey is enclosed with fire-resisting construction at the ground storey level and discharges to a final exit independent of the ground storey (see Diagram 23).

**Diagram 22 Maximum travel distance in a small two-storey premises with a single open stair**

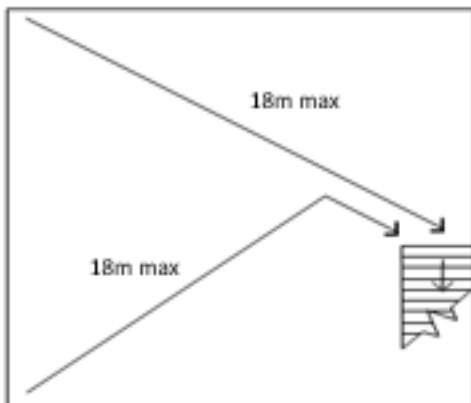
a. FIRST STOREY



b. GROUND STOREY



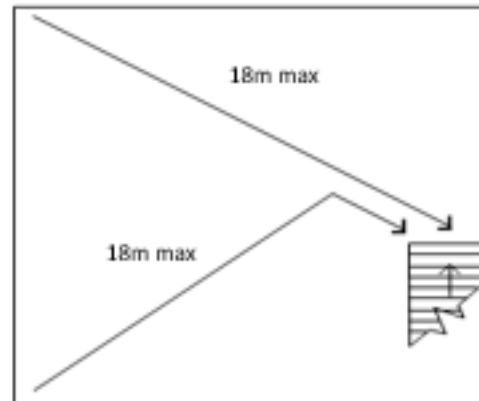
c. BASEMENT



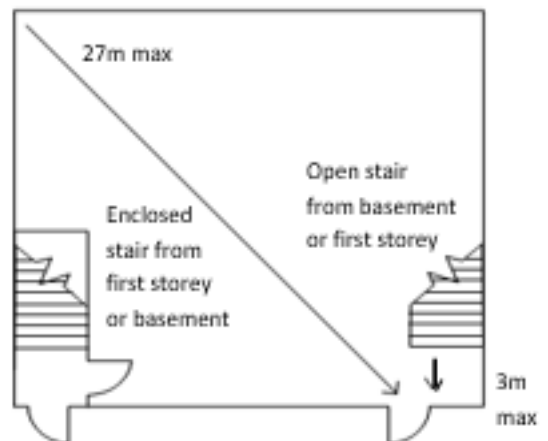
Note 1: Maximum floor area in any one storey 90m<sup>2</sup>  
 Note 2: The premises may not be used as a restaurant or bar  
 Note 3: Only acceptable in two storey premises (a+b or b+c)  
 Note 4: Travel distances are set out in Table 4

**Diagram 23 Maximum travel distance in a small three-storey premises with a single stair to each storey**

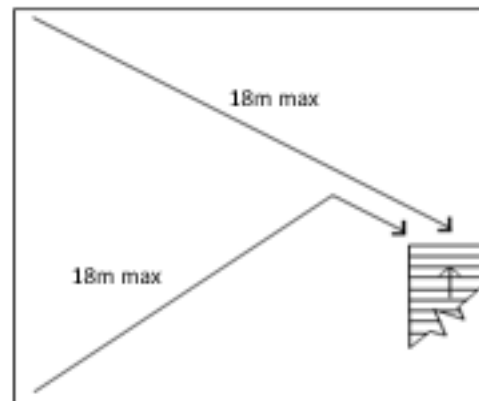
a. FIRST STOREY



b. GROUND STOREY



c. BASEMENT



Note 1: Maximum floor area in any one storey 90m<sup>2</sup>  
 Note 2: Enclosed stair at ground storey level may be from either the basement or the first storey  
 Note 3: The premises may not be used as a restaurant or bar  
 Note 4: Travel distances are set out in Table 4.

## Section 5

### Access lobbies and corridors

**5.34** There are situations where an escape stair needs the added protection of a protected lobby or protected corridor. These are:

- a. where the stair is the only one serving a building (or part of a building) which has more than one storey above or below the ground storey (except for small premises covered in paragraph 5.6a); or
- b. where the stair serves any storey at a height greater than 18m; or
- c. where the building is designed for phased evacuation (see paragraph 5.29a).

In these cases protected lobbies or protected corridors are needed at all levels, except the top storey and at all basement levels; or

- d. where the stair is a firefighting stair.

Lobbies are also needed where the option in paragraph 5.21(b) has been used so as not to discount one stairway when calculating stair widths.

An alternative that may be considered in (a) to (c) above is to use a smoke control system as described in paragraph 5.21(a).

**5.35** A protected lobby should be also provided between an escape stairway and a place of special fire hazard. In this case, the lobby should have not less than 0.4m<sup>2</sup> permanent ventilation, or be protected from the ingress of smoke by a mechanical smoke control system.

### Exits from protected stairways

**5.36** Every protected stairway should discharge:

- a. directly to a final exit; or
- b. by way of a protected exit passageway to a final exit.

**Note:** Any such protected exit passageway should have the same standard of fire resistance and lobby protection as the stairway it serves.

The exit from a protected stairway should meet the provisions in paragraphs 6.30 to 6.34.

### Separation of adjoining stairways

**5.37** Where two protected stairways are adjacent, they and any protected exit passageways linking them to final exits, should be separated by an imperforate enclosure.

### Use of space within protected stairways

**5.38** A protected stairway needs to be free of potential sources of fire. Consequently, facilities that may be incorporated in a protected stairway are limited to the following:

## Section 5

- a. sanitary accommodation or washrooms, so long as the accommodation is not used as a cloakroom. A gas water heater or sanitary towel incinerator may be installed in the accommodation but not any other gas appliance;
- b. a lift well may be included in a protected stairway, if it is not a firefighting stair;
- c. a reception desk or enquiry office area at ground or access level, if it is not in the only stair serving the building or part of the building. The reception or enquiry office area should not be more than 10m<sup>2</sup> in area; and/or
- d. cupboards enclosed with fire-resisting construction, if it is not in the only stair serving the building or part of the building.

### External walls of protected stairways

**5.39** The external enclosures to protected stairways should meet the provisions in paragraph 6.24.

### Gas service pipes in protected stairways

**5.40** Gas service and installation pipes or associated meters should not be incorporated within a protected stairway unless the gas installation is in accordance with the requirements for installation and connection set out in the *Pipelines Safety Regulations 1996, SI 1996 No 825 and the Gas Safety (Installation and Use) Regulations 1998 SI 1998 No 2451*. (See also paragraph 9.40.)

### Basement stairs

**5.41** Because of their situation, basement stairways are more likely to be filled with smoke and heat than stairs in ground and upper storeys.

Special measures are therefore needed in order to prevent a basement fire endangering upper storeys. These are set out in the following two paragraphs.

**5.42** If an escape stair forms part of the only escape route from an upper storey of a building (or part of a building) it should not be continued down to serve any basement storey. The basement should be served by a separate stair.

**5.43** If there is more than one escape stair from an upper storey of a building (or part of a building), only one of the stairs serving the upper storeys of the building (or part) need be terminated at ground level. Other stairs may connect with the basement storey(s) if there is a protected lobby, or a protected corridor between the stair(s) and accommodation at each basement level.

### External escape stairs

**5.44** If more than one escape route is available from a storey (or part of a building), some of the escape routes from that storey or part of the building may be by way of an external escape stair, provided that:

- a. there is at least one internal escape stair from every part of each storey (excluding plant areas);
- b. in the case of an Assembly and Recreation building, the route is not intended for use by members of the public; or

## Section 5

- c. in the case of an Institutional building, the route serves only office or residential staff accommodation.

**5.45** Where external stairs are acceptable as forming part of an escape route, they should meet the provisions in paragraph 6.25.



## Section 6

## B1

# General provisions

### Introduction

- 6.1** This Section gives guidance on the construction and protection of escape routes generally, service installations and other matters associated with the design of escape routes. It applies to all buildings.

It should therefore be read in conjunction with Section 3 (in respect of flats) and in conjunction with Sections 4 and 5 (in respect of other buildings).

### Protection of escape routes

#### Fire resistance of enclosures

- 6.2** Details of fire resistance test criteria and standards of performance, are set out in Appendix A. Generally, a 30-minute standard is sufficient for the protection of means of escape. The exceptions to this are when greater fire resistance is required by the guidance on Requirements B3 or B5, or some other specific instance to meet Requirement B1, in Sections 3 and 4.
- 6.3** All walls, partitions and other enclosures that need to be fire-resisting to meet the provisions in this Approved Document (including roofs that form part of a means of escape), should have the appropriate performance given in Tables A1 and A2 of Appendix A.
- 6.4** Elements protecting a means of escape should meet any limitations on the use of glass (see paragraph 6.7).

#### Fire resistance of doors

- 6.5** Details of fire resistance test criteria and standards of performance, are set out in Appendix B.
- 6.6** All doors that need to be fire-resisting to meet the provisions in this Approved Document should have the appropriate performance given in Table B1 of Appendix B. Doors should also meet any limitations on the use of glass (see paragraph 6.7).

#### Fire resistance of glazed elements

- 6.7** Where glazed elements in fire-resisting enclosures and doors are only able to satisfy the relevant performance in terms of integrity, the use of glass is limited. These limitations depend on whether the enclosure forms part of a protected shaft (see Section 9) and the provisions set out in Appendix A, Table A4.
- 6.8** Where the relevant performance can be met in terms of both integrity and insulation, there is no restriction in this Approved Document on the use or amount of glass.
- 6.9** Attention is also drawn to the guidance on the safety of glazing in Approved Document N *Glazing – safety in relation to impact, opening and cleaning*.

## Section 6

### Doors on escape routes

**6.10** The time taken to negotiate a closed door can be critical in escaping. Doors on escape routes (both within and from the building) should therefore be readily openable, if undue delay is to be avoided. Accordingly the provisions in paragraphs 6.11 to 6.18 should be met.

### Door fastenings

**6.11** In general, doors on escape routes (whether or not the doors are fire doors), should either not be fitted with lock, latch or bolt fastenings, or they should only be fitted with simple fastenings that can be readily operated from the side approached by people making an escape. The operation of these fastenings should be readily apparent; without the use of a key and without having to manipulate more than one mechanism. This is not intended to prevent doors being fitted with hardware to allow them to be locked when the rooms are empty. There may also be situations such as hotel bedrooms where locks may be fitted that are operated from the outside by a key and from the inside by a knob or lever, etc.

Where a door on an escape route has to be secured against entry when the building or part of the building is occupied, it should only be fitted with a lock or fastening which is readily operated, without a key, from the side approached by people making their escape. Similarly, where a secure door is operated by a code, combination, swipe or proximity card, biometric data or similar means, it should also be capable of being overridden from the side approached by people making their escape.

Electrically powered locks should return to the unlocked position:

- a. on operation of the fire alarm system;
- b. on loss of power or system error;
- c. on activation of a manual door release unit (Type A) to BS EN 54-11:2001 positioned at the door on the side approached by people making their escape. Where the door provides escape in either direction, a unit should be installed on both sides of the door.

**6.12** In the case of places of assembly, shop and commercial buildings, doors on escape routes from rooms with an occupant capacity of more than 60 should either not be fitted with lock, latch or bolt fastenings, or be fitted with panic fastenings in accordance with BS EN 1125:1997.

In non-residential buildings it may also be appropriate to accept on some final exit doors locks for security that are used only when the building is empty. In these cases the emphasis for the safe use of these locks must be placed on management procedures.

**6.13** Guidance about door closing and 'hold open' devices for fire doors is given in Appendix B.

### Direction of opening

**6.14** The door of any doorway or exit should, if reasonably practicable, be hung to open in the direction of escape and should always do so if the number of persons that might be expected to use the door at the time of a fire is more than 60.

## Section 6

**Note:** Where there is a very high fire risk with potential for rapid fire growth, such as with some industrial activities, doors should open in the direction of escape even where the number of persons does not exceed 60.

### Amount of opening and effect on associated escape routes

- 6.15** All doors on escape routes should be hung to open not less than 90 degrees with a swing that is clear of any change of floor level, other than a threshold or single step on the line of the doorway (see paragraph 6.21) and which does not reduce the effective width of any escape route across a landing.
- 6.16** A door that opens towards a corridor or a stairway should be sufficiently recessed to prevent its swing from encroaching on the effective width of the stairway or corridor.

### Vision panels in doors

- 6.17** Vision panels are needed where doors on escape routes sub-divide corridors, or where any doors are hung to swing both ways. Note also the provision in Approved Document M *Access to and Use of buildings*, concerning vision panels in doors across accessible corridors and passageways and the provisions for the safety of glazing in Approved Document N *Glazing – safety in relation to impact, opening and cleaning*.

### Revolving and automatic doors

- 6.18** Revolving doors, automatic doors and turnstiles can obstruct the passage of persons escaping. Accordingly, they should not be placed across escape routes unless:
- they are to the required width and are automatic doors and either they:
    - are arranged to fail safely to outward opening from any position of opening; or
    - are provided with a monitored failsafe system for opening the doors if the mains supply fails; or
    - they fail safely to the open position in the event of power failure; or
  - non-automatic swing doors of the required width are provided immediately adjacent to the revolving or automatic door or turnstile.

## Stairs

### Construction of escape stairs

- 6.19** The flights and landings of every escape stair should be constructed of materials of limited combustibility in the following situations:
- if it is the only stair serving the building, or part of the building, unless the building is of two or three storeys and is in Purpose Group 1(a) or Purpose Group 3;
  - if it is within a basement storey (this does not apply to a private stair in a flat);
  - if it serves any storey having a floor level more than 18m above ground or access level;
  - if it is external, except in the case of a stair that connects the ground floor or paving level with a floor or flat roof not more than 6m above or below ground level. (There is further guidance on external escape stairs in paragraph 6.25); or
  - if it is a firefighting stair (see Section 18).

**Note:** In satisfying the above conditions, combustible materials may be added to the horizontal surface of these stairs (except in the case of firefighting stairs).

## Section 6

- 6.20** There is further guidance on the construction of firefighting stairs in Section 18. Dimensional constraints on the design of stairs generally, to meet requirements for safety in use, are given in Approved Document K, *Protection from falling, collision and impact*.

### Single steps

- 6.21** Single steps may cause falls and should only be used on escape routes where they are prominently marked. A single step on the line of a doorway is acceptable, subject to paragraph 6.32.

### Helical stairs, spiral stairs and fixed ladders

- 6.22** Helical stairs, spiral stairs and fixed ladders may form part of an escape route subject to the following restrictions:
- helical and spiral stairs should be designed in accordance with BS 5395-2:1984 and, if they are intended to serve members of the public, should be a type E (public) stair, in accordance with that standard; and
  - fixed ladders should not be used as a means of escape for members of the public and should only be intended for use in circumstances where it is not practical to provide a conventional stair, for example, as access to plant rooms that are not normally occupied.
- 6.23** Guidance on the design of helical and spiral stairs and fixed ladders, from the aspect of safety in use, is given in Approved Document K *Protection from falling, collision and impact*.

### External walls of protected stairways

- 6.24** With some configurations of external wall, a fire in one part of a building could subject the external wall of a protected stairway to heat (for example, where the two are adjacent at an internal angle in the facade as shown in Diagram 24). If the external wall of the protected stairway has little fire resistance, there is a risk that this could prevent the safe use of the stair.

Therefore, if:

- a protected stairway projects beyond, or is recessed from, or is in an internal angle of, the adjoining external wall of the building; then
- the distance between any unprotected area in the external enclosures to the building and any unprotected area in the enclosure to the stairway should be at least 1800mm (see Diagram 24).

### External escape stairs

- 6.25** Where an external escape stair is provided in accordance with paragraph 5.44, it should meet the following provisions:
- all doors giving access to the stair should be fire-resisting and self-closing, except that a fire-resisting door is not required at the head of any stair leading downwards where there is only one exit from the building onto the top landing;

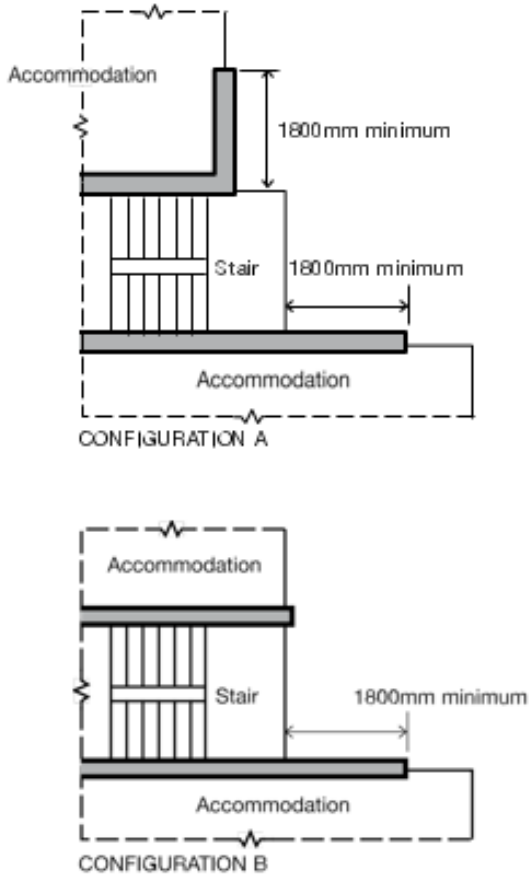
**Section 6**

- b. any part of the external envelope of the building within 1800mm of (and 9m vertically below), the flights and landings of an external escape stair should be of fire-resisting construction, except that the 1800mm dimension may be reduced to 1100mm above the top level of the stair if it is not a stair up from a basement to ground level (see Diagram 25);
- c. there is protection by fire-resisting construction for any part of the building (including any doors) within 1800mm of the escape route from the stair to a place of safety, unless there is a choice of routes from the foot of the stair that would enable the people escaping to avoid exposure to the effects of the fire in the adjoining building;
- d. any stair more than 6m in vertical extent is protected from the effects of adverse weather conditions. (This should not be taken to imply a full enclosure. Much will depend on the location of the stair and the degree of protection given to the stair by the building itself); and
- e. glazing in areas of fire-resisting construction mentioned above should also be fire-resisting (integrity but not insulation) and fixed shut.

**Diagram 24 External protection to protected stairways**

See para 6.24

CONFIGURATIONS OF STAIRS AND EXTERNAL WALL

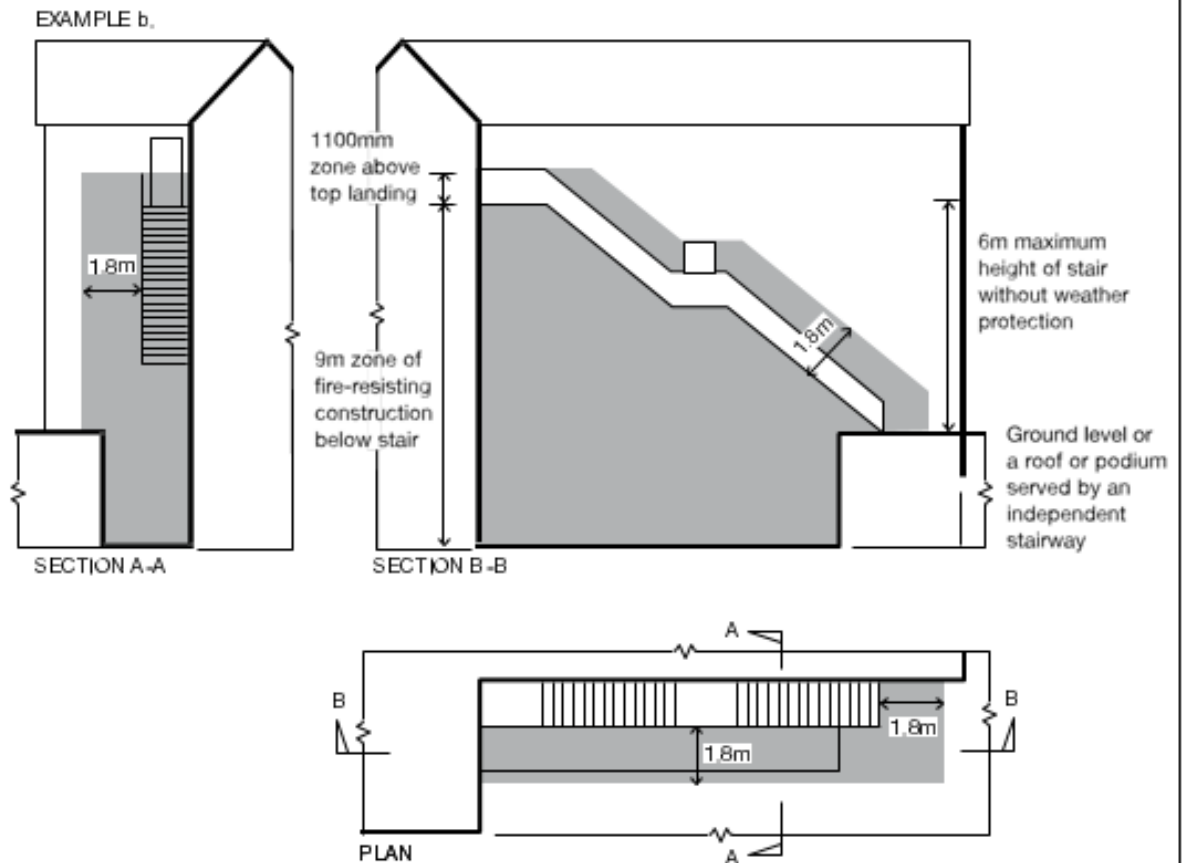
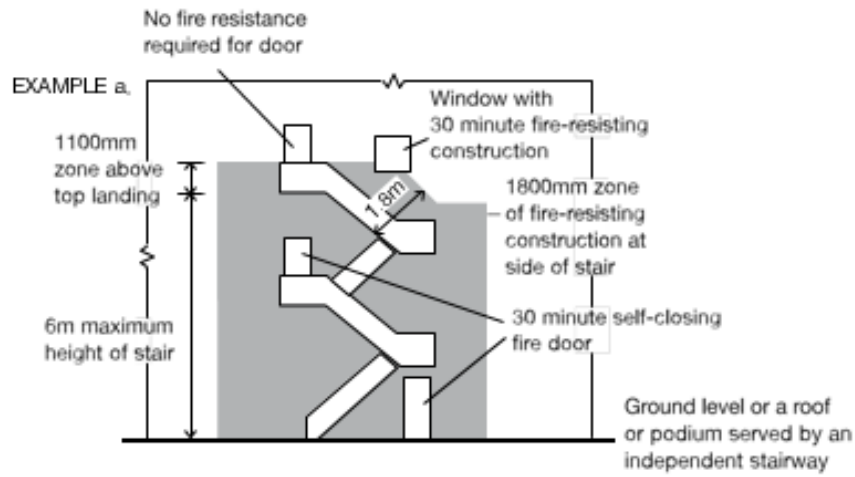


**Key**  
 — Fire-resisting construction  
 — Non fire-resisting construction

Section 6

**Diagram 25 Fire resistance of areas adjacent to external stairs**

See para 6.25



## Section 6

### General

#### Headroom in escape routes

**6.26** All escape routes should have a clear headroom of not less than 2m and there should be no projection below this height (except for door frames).

#### Floors of escape routes

**6.27** The floorings of all escape routes (including the treads of steps and surfaces of ramps and landings) should be chosen to minimise their slipperiness when wet.

#### Ramps and sloping floors

**6.28** Where a ramp forms part of an escape route it should meet the provisions in Approved Document M Access to and Use of buildings. Any sloping floor or tier should be constructed with a pitch of not more than 35° to the horizontal.

**6.29** Further guidance on the design of ramps and associated landings and on aisles and gangways in places where there is fixed seating, from the aspect of safety in use, is given in Approved Document K Protection from falling, collision and impact and in Approved Document M Access to and Use of buildings. The design of means of escape in places with fixed seating is dealt with in Section 4 by reference to BS 5588-6:1991.

#### Final exits

**6.30** Final exits need to be dimensioned and sited to facilitate the evacuation of persons out of and away from the building. Accordingly, they should be not less in width than the minimum width required for the escape route(s) they serve and should also meet the conditions in paragraphs 6.31 to 6.34.

**6.31** Final exits should be sited to ensure rapid dispersal of persons from the vicinity of the building so that they are no longer in danger from fire and smoke. Direct access to a street, passageway, walkway or open space should be available. The route clear of the building should be well defined and, if necessary, have suitable guarding.

**6.32** Final exits should not present an obstacle to wheelchair users and other people with disabilities. Where a final exit is accessed without the need to first traverse steps then a level threshold and, where necessary, a ramp should be provided.

**6.33** Final exits need to be apparent to persons who may need to use them. This is particularly important where the exit opens off a stair that continues down, or up, beyond the level of the final exit.

**6.34** Final exits should be sited so that they are clear of any risk from fire or smoke in a basement (such as the outlets to basement smoke vents, see Section 19), or from openings to transformer chambers, refuse chambers, boiler rooms and similar risks.

#### Escape routes over flat roofs

**6.35** Where an escape route over a flat roof is provided in accordance with paragraph 3.31 or 4.31, it should meet the following provisions:

- a. the roof should be part of the same building from which escape is being made;
- b. the route across the roof should lead to a storey exit or external escape route;

## Section 6

- c. the part of the roof forming the escape route and its supporting structure, together with any opening within 3m of the escape route, should be fire-resisting (see Appendix A Table A1); and
- d. the route should be adequately defined and guarded by walls and/or protective barriers which meet the provisions in Approved Document K, *Protection from falling, collision and impact*.

### Lighting of escape routes

**6.36** All escape routes should have adequate artificial lighting. Routes and areas listed in Table 9 should also have escape lighting which illuminates the route if the main supply fails.

Lighting to escape stairs should be on a separate circuit from that supplying any other part of the escape route.

Standards for the installation of a system of escape lighting are given in BS 5266-1:2005.

### Exit signs

**6.37** Except within a flat, every escape route (other than those in ordinary use) should be distinctively and conspicuously marked by emergency exit sign(s) of adequate size complying with the *Health and Safety (Safety signs and signals) Regulations 1996*. In general, signs containing symbols or pictograms which conform to BS 5499-1:2002, satisfy these regulations. In some buildings additional signs may be needed to meet requirements under other legislation.

Suitable signs should also be provided for refuges (see paragraph 5.10).

**Note:** Advice on fire safety signs, including emergency escape signs, is given in an HSE publication: *Safety Signs and Signals: Guidance on Regulations*.

### Protected power circuits

**6.38** Where it is critical for electrical circuits to be able to continue to function during a fire, protected circuits are needed. The potential for damage to cables forming protected circuits should be limited by the use of sufficiently robust cables, careful selection of cable routes and/or by the provision of physical protection in areas where cables may be susceptible to damage. Methods of cable support should generally be non-combustible and such that circuit integrity will not be reduced below that afforded by the cable.

A protected circuit for operation of equipment in the event of fire should consist of cable meeting at least the requirements for PH 30 classification when tested in accordance with BS EN 50200:2006 (incorporating Appendix E), or an equivalent standard. It should follow a route selected to pass only through parts of the building in which the fire risk is negligible and should be separate from any circuit provided for another purpose.

In large or complex buildings there may be fire protection systems that need to operate for an extended period during a fire. Further guidance on the selection of cables for such systems is given in BS 5839-1, BS 5266-1 and BS 7346-6.



Section 6

<b>Table 9 Provisions for escape lighting</b>	
<b>Purpose group of the building or part of the building</b>	<b>Areas requiring escape lighting</b>
1. Residential	All common escape routes <sup>(1)</sup> , except in 2-storey flats
2. Office, Industrial, storage and Other non-residential	<ul style="list-style-type: none"> <li>a. Underground or windowless accommodation</li> <li>b. Stairways in a central core or serving storey(s) more than 18m above ground level</li> <li>c. Internal corridors more than 30m long</li> <li>d. Open-plan areas of more than 60m<sup>2</sup></li> </ul>
3. Shop and Commercial and car parks	<ul style="list-style-type: none"> <li>a. Underground or windowless accommodation</li> <li>b. Stairways in a central core or serving storey(s) more than 18m above ground level</li> <li>c. Internal corridors more than 30m long</li> <li>d. Open-plan areas of more than 60m<sup>2</sup></li> <li>e. All escape routes to which the public are admitted<sup>(1)</sup> (except in shops of three or fewer storeys with no sales floor more than 280m<sup>2</sup>, provided that the shop is not a restaurant or bar)</li> </ul>
4. Assembly and Recreation	All escape routes <sup>(1)</sup> , and accommodation except for: <ul style="list-style-type: none"> <li>a. accommodation open on one side to view sport or entertainment during normal daylight hours</li> </ul>
5. Any Purpose Group	<ul style="list-style-type: none"> <li>a. All toilet accommodation with a floor area over 8m<sup>2</sup></li> <li>b. Electricity and generator rooms</li> <li>c. Switch room/battery room for emergency lighting system</li> <li>d. Emergency control room</li> </ul>
<b>Notes:</b>	
1. Including external escape routes	

## Lifts

### Evacuation lifts

**6.39** In general it is not appropriate to use lifts when there is a fire in the building because there is always the danger of people being trapped in a lift that has become immobilised as a result of the fire. However, in some circumstances a lift may be provided as part of a management plan for evacuating people. In such cases the lift installation may need to be appropriately sited and protected and may need to contain a number of safety features that are intended to ensure that the lift remains usable for evacuation purposes during the fire. Guidance on the design and use of evacuation lifts is given in BS 5588-8:1999.

Where a firefighting lift has been provided to satisfy requirement B5, this can be utilised as part of a management plan for evacuating disabled people. Any such plan should include a contingency for when the Fire and Rescue Service arrive.

## Section 6

### Fire protection of lift installations

- 6.40** Because lifts connect floors, there is the possibility that they may prejudice escape routes. To safeguard against this, the conditions in paragraphs 6.41 to 6.45 should be met.
- 6.41** Lifts, such as wall-climber or feature lift which rise within a large volume, such as a mall or atrium, and do not have a conventional well, may be at risk if they run through a smoke reservoir. In which case, care is needed to maintain the integrity of the smoke reservoir and protect the occupants of the lift.
- 6.42** Lift wells should be either:
- contained within the enclosures of a protected stairway; or
  - enclosed throughout their height with fire-resisting construction if they are sited so as to prejudice the means of escape.

A lift well connecting different compartments should form a protected shaft (see Section 9).

In buildings designed for phased or progressive horizontal evacuation, where the lift well is not contained within the enclosures of a protected stairway, the lift entrance should be separated from the floor area on every storey by a protected lobby.

- 6.43** In basements and enclosed (non open-sided) car parks the lift should be approached only by a protected lobby (or protected corridor), unless it is within the enclosure of a protected stairway.

This is also the case in any storey that contains high fire risk areas, if the lift also delivers directly into corridors serving sleeping accommodation. Examples of fire risk areas in this context are kitchens, communal lounges and stores.

- 6.44** A lift shaft should not be continued down to serve any basement storey if it is:
- in a building (or part of a building) served by only one escape stair and smoke from a basement fire would be able to prejudice the escape routes in the upper storeys; or
  - within the enclosure to an escape stair which is terminated at ground level.
- 6.45** Lift machine rooms should be sited over the lift well whenever possible. If the lift well is within a protected stairway which is the only stairway serving the building (or part of the building), then if the machine room cannot be sited above the lift well, it should be located outside the stairway (to avoid smoke spread from a fire in the machine room).

### Mechanical ventilation and air-conditioning systems

- 6.46** Any system of mechanical ventilation should be designed to ensure that, in a fire, the ductwork does not assist in transferring fire and smoke through the building and put at risk the protected means of escape from the accommodation areas. Any exhaust points should be sited so as not to further jeopardize the building, i.e. away from final exits, combustible building cladding or roofing materials and openings into the building.

## Section 6

**6.47** Ventilation ducts supplying or extracting air directly to or from a protected escape route, should not also serve other areas. A separate ventilation system should be provided for each protected stairway. Guidance on ventilation systems that circulate air only within an individual flat is given in paragraph 3.18.

Where the ductwork system serves more than one part of a sub-divided (see paragraph 4.26) escape route, a fire damper should be provided where ductwork enters each section of the escape route operated by a smoke detector or suitable fire detection system (see also Section 11). The fire dampers should close when smoke is detected.

**6.48** Ducts passing through the enclosure of a protected escape route should be fire-resisting, i.e. the ductwork should be constructed in accordance with Method 2 or Method 3, (see paragraph 11.9).

**Note:** Fire dampers activated only by fusible links are not suitable for protecting escape routes. However an ES classified fire and smoke damper which is activated by a suitable fire detection system may be used. See paragraph 11.15.

**6.49** In the case of a system which recirculates air, smoke detectors should be fitted in the extract ductwork before the point of separation of the recirculated air and the air to be discharged to the open air and before any filters or other air cleaning equipment. Such detector(s) should:

- a. cause the system to immediately shut down; or
- b. switch the ventilation system from recirculating mode to extraction to open air, so as to divert any smoke to the outside of the building.

**6.50** Non-domestic kitchens, car parks and plant rooms should have separate and independent extraction systems and the extracted air should not be recirculated.

**6.51** Guidance on the use of mechanical ventilation in a place of assembly is given in BS 5588-6:1991.

**6.52** Where a pressure differential system is installed, ventilation and air-conditioning systems in the building should be compatible with it when operating under fire conditions.

**6.53** Further guidance on the design and installation of mechanical ventilation and air conditioning plant is given in BS 5720:1979. Guidance on the provision of smoke detectors in ventilation ductwork is given in BS 5839-1:2002.

**Note:** Paragraphs 9.41 and 11.9 also deal with ventilation and air-conditioning ducts.

## Refuse chutes and storage

**6.54** Refuse storage chambers, refuse chutes and refuse hoppers should be sited and constructed in accordance with BS 5906 *Code of practice for storage and on-site treatment of solid waste from buildings*.

**6.55** Refuse chutes and rooms provided for the storage of refuse should:

## Section 6

- a. be separated from other parts of the building by fire-resisting construction; and
- b. not be located within protected stairways or protected lobbies.

- 6.56** Rooms containing refuse chutes, or provided for the storage of refuse, should be approached either directly from the open air or by way of a protected lobby provided with not less than  $0.2\text{m}^2$  of permanent ventilation.
- 6.57** Access to refuse storage chambers should not be sited adjacent to escape routes or final exits, or near to windows of flats.

### Shop store rooms

- 6.58** Fully enclosed walk-in store rooms in shops (unless provided with an automatic fire detection and alarm system or fitted with an automatic fire suppression system) should be separated from retail areas with fire-resisting construction (see Appendix A, Table A1), if they are sited so as to prejudice the means of escape.

# Internal Fire Spread (Linings)

# B2

## The Requirement

This Approved Document deals with the following Requirement from Part B of Schedule 1 to the Building Regulations 2010.

Requirement	Limits on application
<p><b>Internal fire spread (linings)</b></p> <p><b>B2.</b> (1) To inhibit the spread of fire within the building, the internal linings shall:</p> <ul style="list-style-type: none"> <li>(a) adequately resist the spread of flame over their surfaces; and</li> <li>(b) have, if ignited, a rate of heat release or a rate of fire growth, which is reasonable in the circumstances.</li> </ul> <p>(2) In this paragraph 'internal linings' mean the materials or products used in lining any partition, wall, ceiling or other internal structure.</p>	

# Guidance

# B2

---

## Performance

In the Welsh Ministers' view the Requirements of B2 will be met if the spread of flame over the internal linings of the building is restricted by making provision for them to have low rates of surface spread of flame and, in some cases, to have a low rate of heat release, so as to limit the contribution that the fabric of the building makes to fire growth. In relation to the European fire tests and classification system, the requirements of B2 will be met if the heat released from the internal linings is restricted by making provision for them to have a resistance to ignition and a rate of fire growth which are reasonable in the circumstances.

The extent to which this is necessary is dependent on the location of the lining.

## Introduction

### Fire spread and lining materials

**B2.i** The choice of materials for walls and ceilings can significantly affect the spread of a fire and its rate of growth, even though they are not likely to be the materials first ignited.

It is particularly important in circulation spaces where linings may offer the main means by which fire spreads and where rapid spread is most likely to prevent occupants from escaping.

Several properties of lining materials influence fire spread. These include the ease of ignition and the rate at which the lining material gives off heat when burning. The guidance relating to the European fire tests and classification provides for control of internal fire spread through control of these properties. This document does not give detailed guidance on other properties such as the generation of smoke and fumes.

### Floors and stairs

**B2.ii** The provisions do not apply to the upper surfaces of floors and stairs because they are not significantly involved in a fire until well developed and thus do not play an important part in fire spread in the early stages of a fire that are most relevant to the safety of occupants.

However, it should be noted that the construction of some stairs and landings is controlled under Section 6, paragraph 6.19 and in the case of firefighting stairs, Section 18, paragraph 18.11.

## Section 6

### Other controls on internal surface properties

**B2.iii** There is also guidance on the control of flame spread inside buildings in two other Sections. In Section 9 there is guidance on surfaces exposed in concealed spaces above fire-protecting suspended ceilings and in Section 11 on enclosures to above ground drainage system pipes.

**Note:** External flame spread is dealt with in Sections 13 to 15; the fire behaviour of insulating core panels used for internal structures is dealt with in Appendix F.

### Furniture and fittings

**B2.iv** Furniture and fittings can have a major effect on fire spread but it is not possible to control them through Building Regulations and they are not dealt with in this Approved Document. Fire characteristics of furniture and fittings may be controlled in some buildings under legislation that applies to a building in use, such as licensing conditions.

### Classification of performance

**B2.v** Appendix A describes the different classes of performance and the appropriate methods of test (see paragraphs 13 to 20).

The National classifications used are based on tests in BS 476 Fire tests on building materials and structures, namely Part 6: *Method of test for fire propagation for products* and Part 7: *Method of test to determine the classification of the surface spread of flame of products*. However, Part 4: *Non-combustibility test for materials* and Part 11: *Method for assessing the heat emission from building products* are also used as one method of meeting Class 0. Other tests are available for classification of thermoplastic materials if they do not have the appropriate rating under BS 476-7 and three ratings, referred to as TP(a) rigid and TP(a) flexible and TP(b), are used.

The European classifications are described in BS EN 13501-1: 2007, *Fire classification of construction products and building elements, Part 1 – Classification using data from reaction to fire tests*. They are based on a combination of four European test methods, namely:

- BS EN ISO 1182:2002 *Reaction to fire tests for building products – Non combustibility test*;
- BS EN ISO 1716:2002 *Reaction to fire tests for building products – Determination of the gross calorific value*;
- BS EN 13823:2002 *Reaction to fire tests for building products – Building products excluding floorings exposed to the thermal attack by a single burning item*; and
- BS EN ISO 11925-2:2002, *Reaction to fire tests for building products. Ignitability when subjected to direct impingement of flame*.

## Section 6

For some building products, there is currently no generally accepted guidance on the appropriate procedure for testing and classification in accordance with the harmonised European fire tests. Until such a time that the appropriate European test and classification methods for these building products are published, classification may only be possible using existing national test methods.

Table A8, in Appendix A, gives typical performance ratings which may be achieved by some generic materials and products.



## Section 7

## B2

# Wall and Ceiling linings

### Classification of linings

**7.1** Subject to the variations and specific provisions described in paragraphs 7.2 to 7.16, the surface linings of walls and ceilings should meet the following classifications:

<b>Table 10 Classification of linings</b>		
<b>Location</b>	<b>National class <sup>(1)</sup></b>	<b>European class <sup>(1)(3)(4)</sup></b>
Small rooms <sup>(2)</sup> of area not more than: a. 4m <sup>2</sup> in residential accommodation b. 30m <sup>2</sup> in non-residential accommodation.	3	D-s3, d2
Other rooms <sup>(2)</sup> including garages	1	C-s3, d2
Circulation spaces within dwellings		
Other circulation spaces, including the common areas of blocks of flats	0	B-s3, d2 <sup>(5)</sup>

**Notes:**

1. See paragraph B2.v.
2. For meaning of room, see definition in Appendix E.
3. The National classifications do not automatically equate with the equivalent classifications in the European column, therefore, products cannot typically assume a European class, unless they have been tested accordingly.
4. When a classification includes 's3, d2', this means that there is no limit set for smoke production and/or flaming droplets/particles.
5. Wall coverings which conform to BS EN 15102:2007 Decorative wallcoverings – roll and panel form products, which achieve at least Class C-s3,d2 and are bonded to a Class A2-s3,d2 substrate will also be acceptable.

### Definition of walls

**7.2** For the purpose of the performance of wall linings, a wall includes:

- a. the surface of glazing (except glazing in doors); and
- b. any part of a ceiling which slopes at an angle of more than 70° to the horizontal.

But a wall does not include:

- c. doors and door frames;

## Section 7

- d. window frames and frames in which glazing is fitted;
- e. architraves, cover moulds, picture rails, skirtings and similar narrow members; or
- f. fireplace surrounds, mantle shelves and fitted furniture.

### Definition of ceilings

**7.3** For the purposes of the performance of ceiling linings, a ceiling includes:

- a. the surface of glazing;
- b. any part of a wall which slopes at an angle of 70° or less to the horizontal;
- c. the underside of a mezzanine or gallery; and
- d. the underside of a roof exposed to the room below.

But a ceiling does not include:

- e. trap doors and their frames;
- f. the frames of windows or rooflights (see Appendix E) and frames in which glazing is fitted; or
- g. architraves, cover moulds, picture rails, exposed beams and similar narrow members.

### Variations and special provisions

#### Walls

**7.4** Parts of walls in rooms may be of a poorer performance than specified in paragraph 7.1 and Table 10 (but not poorer than Class 3 (National class) or Class D-s3, d2 (European class)), provided the total area of those parts in any one room does not exceed one half of the floor area of the room; and subject to a maximum of 20m<sup>2</sup> in residential accommodation and 60m<sup>2</sup> in non-residential accommodation.

#### Fire-protecting suspended ceilings

**7.5** A suspended ceiling can contribute to the overall fire resistance of a floor/ceiling assembly. Such a ceiling should satisfy paragraph 7.1 and Table 10. It should also meet the provisions of Appendix A, Table A3.

#### Fire-resisting ceilings

**7.6** Cavity barriers are needed in some concealed floor or roof spaces (see Section 10); however, this need can be reduced by the use of a fire-resisting ceiling below the cavity. Such a ceiling should comply with Diagram 35.

#### Rooflights

**7.7** Rooflights should meet the relevant classification in 7.1 and Table 10. However plastic rooflights with at least a Class 3 rating may be used where 7.1 calls for a higher standard, provided the limitations in Table 11 and Table 18 are observed.

**Note:** No guidance is currently possible on the performance requirements in the European fire tests as there is no generally accepted test and classification procedure.

## Section 7

### Special applications

- 7.8** Any flexible membrane covering a structure (other than an air supported structure) should comply with the recommendations given in Appendix A of BS 7157:1989.
- 7.9** Guidance on the use of PTFE-based materials for tension-membrane roofs and structures is given in a BRE report *Fire safety of PTFE-based materials used in buildings* (BR 274, BRE 1994).

### Thermoplastic materials

#### General

- 7.10** Thermoplastic materials (see Appendix A, paragraph 17) which cannot meet the performance given in Table 10, can nevertheless be used in windows, rooflights and lighting diffusers in suspended ceilings if they comply with the provisions described in paragraphs 7.11 to 7.15. Flexible thermoplastic material may be used in with the guidance in paragraph 7.16. The classifications used in paragraphs 7.11 to 7.16, Table 11 and Diagram 27 are explained in Appendix A, paragraph 20.

**Note:** No guidance is currently possible on the performance requirements in the European fire tests as there is no generally accepted test and classification procedure.

#### Windows and internal glazing

- 7.11** External windows to rooms (though not to circulation spaces) may be glazed with thermoplastic materials, if the material can be classified as a TP(a) rigid product. Internal glazing should meet the provisions in paragraph 7.1 and Table 10 above.

**Note 1:** A “wall” does not include glazing in a door (see paragraph 7.2).

**Note 2:** Attention is drawn to the guidance on the safety of glazing in Approved Document N *Glazing – safety in relation to impact, opening and cleaning*.

#### Rooflights

- 7.12** Rooflights to rooms and circulation spaces (with the exception of protected stairways) may be constructed of a thermoplastic material if:
- the lower surface has a TP(a) (rigid) or TP(b) classification;
  - the size and disposition of the rooflights accords with the limits in Table 11 and with the guidance to B4 in Tables 17 and 18.

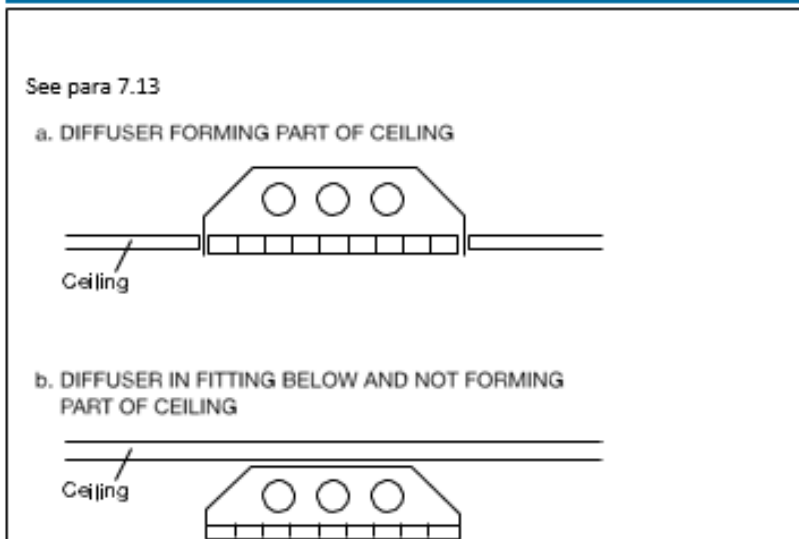
#### Lighting diffusers

- 7.13** The following provisions apply to lighting diffusers which form part of a ceiling and are not concerned with diffusers of light fittings which are attached to the soffit of, or suspended beneath, a ceiling (see Diagram 26).

Lighting diffusers are translucent or open-structured elements that allow light to pass through. They may be part of a luminaire or used below rooflights or other sources of light.

## Section 7

**Diagram 26 Lighting diffuser in relation to ceiling**



- 7.14** Thermoplastic lighting diffusers should not be used in fire-protecting or fire-resisting ceilings, unless they have been satisfactorily tested as part of the ceiling system that is to be used to provide the appropriate fire protection.
- 7.15** Subject to the above paragraphs, ceilings to rooms and circulation spaces (but not protected stairways) may incorporate thermoplastic lighting diffusers if the following provisions are observed:
- Wall and ceiling surfaces exposed within the space above the suspended ceiling (other than the upper surfaces of the thermoplastic panels) should comply with the general provisions of paragraph 7.1 and Table 10, according to the type of space below the suspended ceiling.
  - If the diffusers are of classification TP(a) (rigid), there are no restrictions on their extent.
  - If the diffusers are of classification TP(b), they should be limited in extent as indicated in Table 11 and Diagram 27.

### Suspended or stretched-skin ceilings

- 7.16** The ceiling of a room may be constructed either as a suspended or as a stretched skin membrane from panels of a thermoplastic material of the TP(a) flexible classification, provided that it is not part of a fire-resisting ceiling. Each panel should not exceed 5m<sup>2</sup> in area and should be supported on all its sides.

Section 7

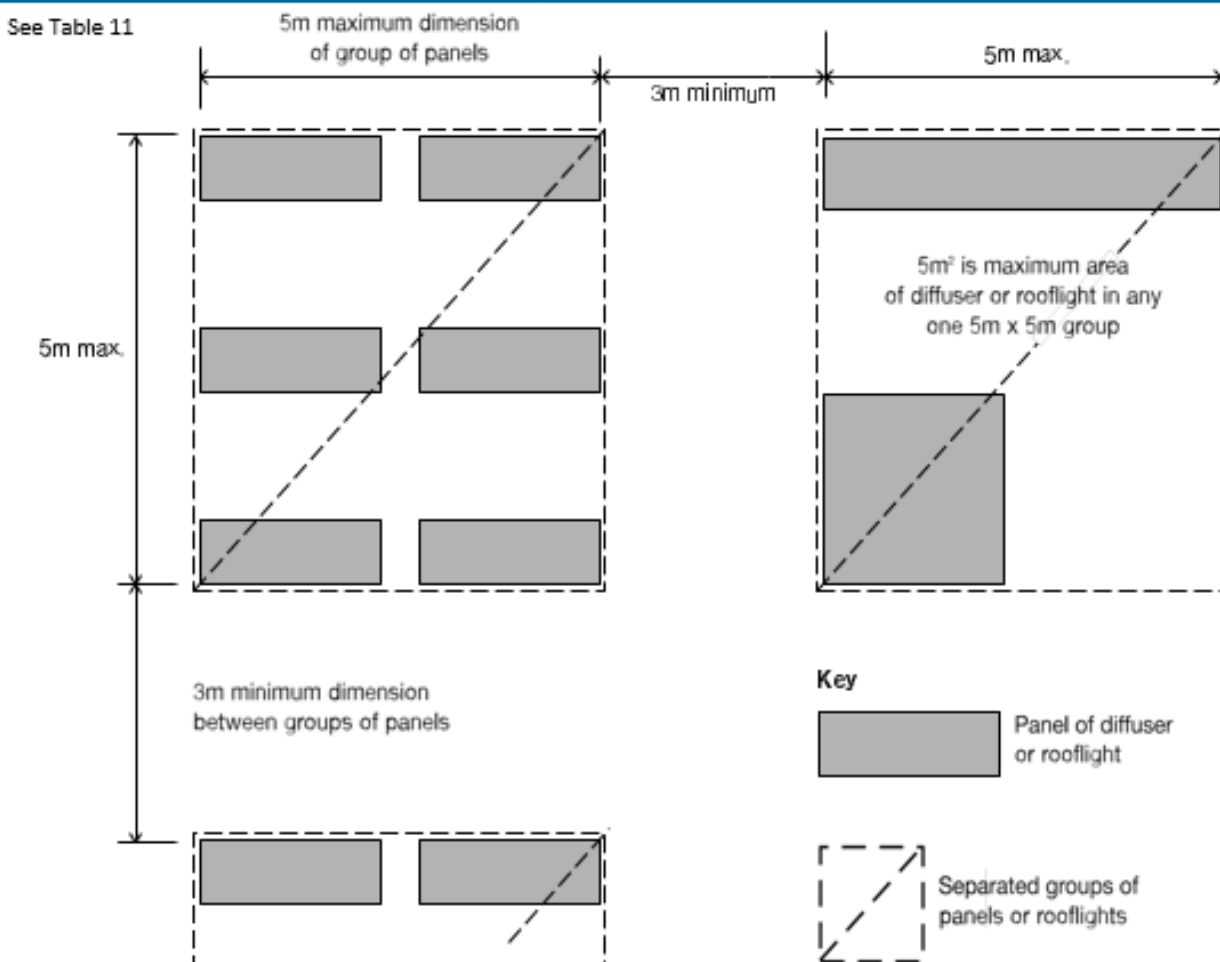
<b>Table 11 Limitations applied to thermoplastic rooflights and lighting diffusers in suspended ceilings and Class 3 plastic rooflights</b>				
<b>Minimum classification of lower surface</b>	<b>Use of space below the diffusers or rooflight</b>	<b>Maximum area of each diffuser panel or rooflight (1) (m<sup>2</sup>)</b>	<b>Max total area of diffuser panels and rooflights as percentage of floor area of the space in which the ceiling is located (%)</b>	<b>Minimum separation distance between diffuser panels or rooflights (1)(m)</b>
TP(a)	Any except protected stairway	No limit (2)	No limit	No limit
D-s3, d2 or Class 3 <sup>(3)</sup> or TP(b)	Rooms	1	50 (4)(5)	A distance equal to the largest plan dimension of the largest diffuser or roof light (see diagram 27A)
		5	50 (4)(5)	3 <sup>(5)</sup>
	Circulation spaces except protected stairways	5	15 (4)	3

**Notes:**

1. Smaller panels can be grouped together provided that the overall size of the group and the space between one group and any others satisfies the dimensions shown in Diagram 27 or 27A.
2. Lighting diffusers of TP(a) flexible rating should be restricted to panels of not more than 5m<sup>2</sup> each, see paragraph 7.16.
3. There are no limits on Class 3 material in small rooms. See paragraph 7.1, Table 10.
4. The minimum separation between each panel or group must be maintained. Therefore, in some cases it may not also be possible to use the maximum percentage quoted.
5. Class 3 / D-s3, d2 rooflights to rooms in industrial and other non-residential purpose groups may be spaced 1800mm apart provided the rooflights are evenly distributed and do not exceed 20% of the area of the room.
6. This table is not relevant to products which meet the provisions in Table 10.

Section 7

**Diagram 27** Layout restrictions on Class 3 plastic rooflights, TP(b) rooflights and TP(b) lighting diffusers



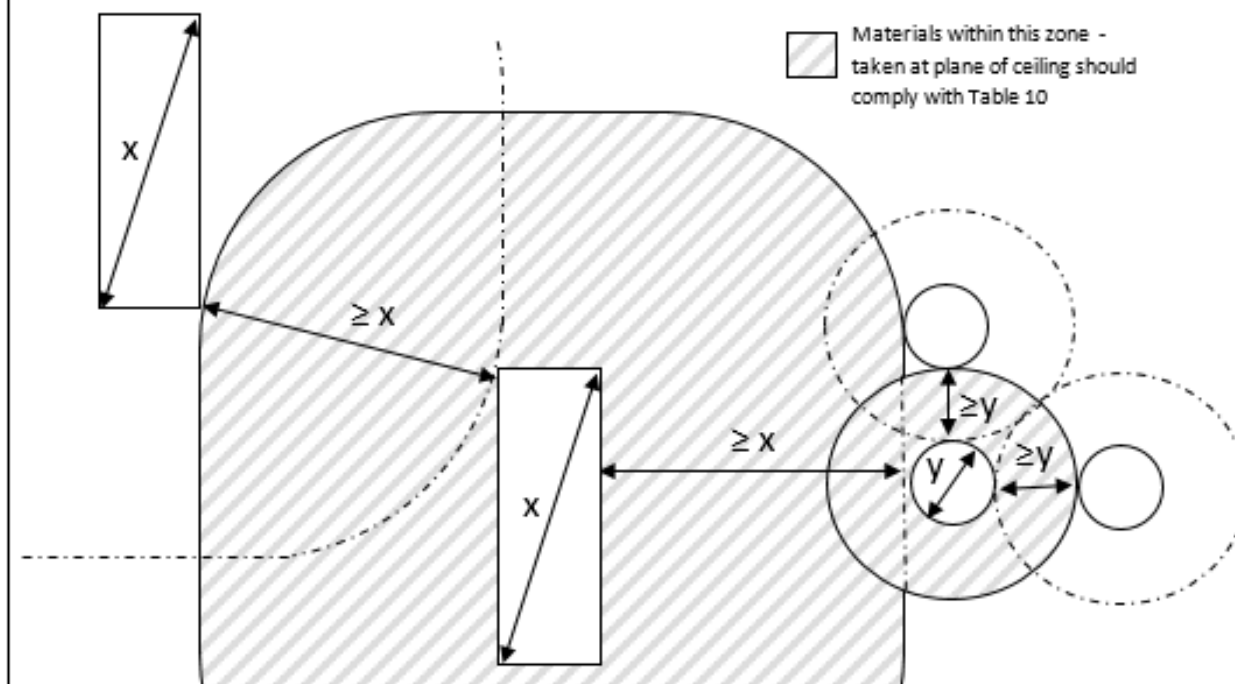
**Notes:**

- a. Upper and lower surface of suspended ceiling, between plastic panels, to comply with paragraph 6.1
- b. No restriction on Class 3 rooflights in small rooms
- c. See Note 5 to Table 11

Section 7

**Diagram 27A Layout restrictions on small Class 3 or D-s3,d2 plastic rooflights, TP(b) rooflights and lighting diffusers**

See Table 11



Section 7

# Internal Fire Spread – Structure B3

## The Requirement

This Approved Document deals with the following Requirement from Part B of Schedule 1 to the Building Regulations 2010.

Requirement	Limits on application
<p><b>Internal fire spread (structure)</b></p> <p><b>B3.</b> (1) The building shall be designed and constructed so that, in the event of fire, its stability will be maintained for a reasonable period:</p> <p>(2) A wall common to two or more buildings shall be designed and constructed so that it adequately resists the spread of fire between those buildings. For the purposes of this subparagraph a house in a terrace and a semi-detached house are each to be treated as a separate building.</p> <p>(3) Where reasonably necessary to inhibit the spread of fire within the building, measures shall be taken, to an extent appropriate to the size and intended use of the building, comprising either or both of the following:</p> <ul style="list-style-type: none"> <li>(a) sub-division of the building with fire-resisting construction;</li> <li>(b) installation of suitable automatic fire suppression systems.</li> </ul> <p>(4) The building shall be designed and constructed so that the unseen spread of fire and smoke within concealed spaces in its structure and fabric is inhibited.</p>	<p>Requirement B3(3) does not apply to material alterations to any prison provided under Section 33 of the Prison Act 1952.</p> <p>(a) 1952 C.52; Section 33 was amended by Section 100 of the Criminal Justice and Public Order Act 1994 (C.33) and by S.I. 1963/597.</p>



## Section 7

# Guidance

# B3

## Performance

In Welsh Ministers' view the Requirements of B3 will be met:

- a. if the loadbearing elements of structure of the building are capable of withstanding the effects of fire for an appropriate period without loss of stability;
- b. if the building is sub-divided by elements of fire-resisting construction into compartments;
- c. if any openings in fire-separating elements (see Appendix E) are suitably protected in order to maintain the integrity of the element (i.e. the continuity of the fire separation); and
- d. if any hidden voids in the construction are sealed and sub-divided to inhibit the unseen spread of fire and products of combustion, in order to reduce the risk of structural failure and the spread of fire, in so far as they pose a threat to the safety of people in and around the building.

The extent to which any of these measures are necessary is dependent on the use of the building and, in some cases, its size and on the location of the element of construction.

## Introduction

**B3.i** Guidance on loadbearing elements of structure is given in Section 8. Section 9 is concerned with the sub-division of a building into compartments and Section 10 makes provisions about concealed spaces (or cavities). Section 11 gives information on the protection of openings and on fire-stopping. Section 12 is concerned with special measures which apply to car parks and shopping complexes. Common to all these sections and to other provisions of Part B, is the property of fire resistance.

## Fire resistance

**B3.ii** The fire resistance of an element of construction is a measure of its ability to withstand the effects of fire in one or more ways, as follows:

- a. resistance to collapse, i.e. the ability to maintain loadbearing capacity (which applies to loadbearing elements only);
- b. resistance to fire penetration, i.e. an ability to maintain the integrity of the element; and
- c. resistance to the transfer of excessive heat, i.e. an ability to provide insulation from high temperatures.

**B3.iii** "Elements of structure" is the term applied to the main structural loadbearing elements, such as structural frames, floors and loadbearing walls. Compartment walls are treated as elements of structure although they are not necessarily loadbearing. Roofs, unless they serve the function of a floor, are not treated as

## Section 7

elements of structure. External walls, such as curtain walls or other forms of cladding which transmit only self weight and wind loads and do not transmit floor load, are not regarded as loadbearing for the purposes of B3.ii(a), although they may need fire resistance to satisfy requirement B4 (see Sections 13 and 14).

Loadbearing elements may or may not have a fire-separating function. Similarly, fire-separating elements may or may not be loadbearing.

## Guidance elsewhere in the Approved Document concerning fire resistance

**B3.iv** There is guidance in Sections 3 to 5 concerning the use of fire-resisting construction to protect means of escape. There is guidance in Section 13 about fire resistance of external walls to restrict the spread of fire between buildings. There is guidance in Section 18 about fire resistance in the construction of firefighting shafts. Appendix A gives information on methods of test and performance for elements of construction. Appendix B gives information on fire doors. Appendix C gives information on methods of measurement. Appendix D gives information on purpose group classification. Appendix E gives definitions.

## Section 8

## B3

# Loadbearing elements of structures

### Introduction

- 8.1** Premature failure of the structure can be prevented by provisions for loadbearing elements of structure to have a minimum standard of fire resistance, in terms of resistance to collapse or failure of loadbearing capacity. The purpose in providing the structure with fire resistance is threefold, namely:
- to minimise the risk to the occupants, some of whom may have to remain in the building for some time while evacuation proceeds if the building is a large one;
  - to reduce the risk to firefighters, who may be engaged on search or rescue operations; and
  - to reduce the danger to people in the vicinity of the building, who might be hurt by falling debris or as a result of the impact of the collapsing structure on other buildings.

### Fire resistance standard

- 8.2** Elements of structure such as structural frames, beams, columns, loadbearing walls (internal and external), floor structures and gallery structures, should have at least the fire resistance given in Appendix A, Table A1.

### Application of the fire resistance standards for loadbearing elements

- 8.3** The measures set out in Appendix A include provisions to ensure that where one element of structure supports or gives stability to another element of structure, the supporting element has no less fire resistance than the other element (see notes to Table A2). The measures also provide for elements of structure that are common to more than one building or compartment, to be constructed to the standard of the greater of, the relevant provisions. Special provisions about fire resistance of elements of structure in single storey buildings are also given and there are concessions in respect of fire resistance of elements of structure in basements where at least one side of the basement is open at ground level.

### Exclusions from the provisions for elements of structure

- 8.4** The following are excluded from the definition of element of structure for the purposes of these provisions:
- a structure that only supports a roof, unless:
    - the roof performs the function of a floor, such as for parking vehicles, or as a means of escape (see Sections 3 to 5); or
    - the structure is essential for the stability of an external wall which needs to have fire resistance;
  - the lowest floor of the building;
  - a platform floor; and
  - a loading gallery, fly gallery, stage grid, lighting bridge, or any gallery provided for similar purposes or for maintenance and repair (see definition of “Element of structure” in Appendix E).

## Section 8

### Additional guidance

**8.5** Guidance in other sections of this Approved Document may also apply if a loadbearing wall is:

- a. a compartment wall (this includes a wall common to two buildings), (see Section 9);
- b. a wall enclosing a place of special fire hazard (see Section 9, paragraph 9.12);
- c. protecting a means of escape, (see Sections 3 to 6);
- d. an external wall, (see Sections 13 and 14); or
- e. enclosing a firefighting shaft, (see Section 18).

**8.6** If a floor is also a compartment floor, see Section 9.

### Raised storage areas

**8.7** Raised free-standing floors (sometimes supported by racking) are frequently erected in single storey industrial and storage buildings. Whether the structure is considered as a gallery or is of sufficient size that it is considered as a floor forming an additional storey, the normal provisions for fire resistance of elements of structure may be onerous if applied to the raised storage area.

**8.8** A structure which does not have the appropriate fire resistance given in Appendix A, Table A1 is acceptable provided the following conditions are satisfied:

- a. the structure has only one tier and is used for storage purposes **only**;
- b. the number of persons likely to be on the floor at any one time is low and does not include members of the public;
- c. the floor is not more than 10m in either width or length and does not exceed one half of the floor area of the space in which it is situated;
- d. the floor is open above and below to the room or space in which it is situated; and
- e. the means of escape from the floor meets the relevant provisions in Sections 4, 5 and 6.

**Note 1:** Where the lower level is provided with an automatic detection and alarm system meeting the relevant recommendations of BS 5839-1:2002, then the floor size may be increased to not more than 20m in either width or length.

**Note 2:** The maximum dimensions provided above have been set in order to limit the distance that a firefighter may need to travel over or under the floor to effect a rescue. Where agreed locally it may be possible to vary these dimensions, however, the safety of firefighters who may be on or underneath these floors must be taken into account.

**Note 3:** Where the building is fitted throughout with an automatic fire suppression system in accordance with section 2, there are no limits on the size of the floor.

## Section 8

### Conversion to flats

- 8.9** Where an existing house or other building is converted into flats, there is a material change of use to which Part B of the regulations applies. Where the existing building has timber floors and these are to be retained, the relevant provisions for fire resistance may be difficult to meet.
- 8.10** Provided that the means of escape conform to Section 3 and are adequately protected, a 30 minute standard of fire resistance could be accepted for the elements of structure in a building having not more than three storeys.

Where the altered building has four or more storeys the full standard of fire resistance given in Appendix A would normally be necessary.

## Section 9

## B3

# Compartmentation

### Introduction

**9.1** The spread of fire within a building can be restricted by sub-dividing it into compartments separated from one another by walls and/or floors of fire-resisting construction. The object is twofold:

- a. to prevent rapid fire spread which could trap occupants of the building; and
- b. to reduce the chance of fires becoming large, on the basis that large fires are more dangerous, not only to occupants and fire and rescue service personnel, but also to people in the vicinity of the building.

Compartmentation is complementary to provisions made in Sections 3 to 6 for the protection of escape routes and to provisions made in Sections 13 to 15 against the spread of fire between buildings.

**9.2** The appropriate degree of sub-division depends on:

- a. the use of and fire load in the building, which affects the potential for fires and the severity of fires, as well as the ease of evacuation;
- b. the height to the floor of the top storey in the building, which is an indication of the ease of evacuation and the ability of the fire and rescue service to intervene effectively; and
- c. the availability of an automatic fire suppression system which affects the growth rate of the fire and may suppress it altogether.

**9.3** Sub-division is achieved using compartment walls and compartment floors. The circumstances in which they are needed are given in paragraphs 9.9 to 9.19.

**9.4** Provisions for the construction of compartment walls and compartment floors are given in paragraphs 9.20 onwards. These construction provisions vary according to the function of the wall or floor.

### Special forms of compartmentation

**9.5** Special forms of compartmentation to which particular construction provisions apply, are:

- a. walls common to two or more buildings, see paragraph 9.10;
- b. walls dividing buildings into separated parts, see paragraph 9.11; and
- c. construction enclosing places of special fire hazard, see paragraph 9.12.

### Junctions

**9.6** For compartmentation to be effective, there should be continuity at the junctions of the fire-resisting elements enclosing a compartment and any openings from one compartment to another should not present a weakness.

## Section 9

### Protected shafts

**9.7** Spaces that connect compartments, such as stairways and service shafts, need to be protected to restrict fire spread between the compartments and they are termed protected shafts. Any walls or floors bounding a protected shaft are considered to be compartment walls or floors for the purpose of this Approved Document.

### Buildings containing one or more atria

**9.8** Detailed advice on all issues relating to the incorporation of atria in buildings is given in BS 5588-7:1997. However, it should be noted that for the purposes of Approved Document B, the standard is relevant **only where the atrium breaches any compartmentation**.

### Provision of compartmentation

#### General

**9.9** Compartment walls and compartment floors should be provided in the circumstances described below, with the proviso that the lowest floor in a building does not need to be constructed as a compartment floor. Paragraphs 9.10 to 9.19 give guidance on the provision of compartmentation in different building types. Information on the construction of compartment walls and compartment floors in different circumstances is given in paragraphs 9.20 to 9.31. Provisions for the protection of openings in compartment walls and compartment floors are given in paragraphs 9.32 to 9.34.

#### All purpose groups

**9.10** A wall common to two or more buildings should be constructed as a compartment wall.

**9.11** Parts of a building that are occupied mainly for different purposes should be separated from one another by compartment walls and/or compartment floors. This does not apply where one of the different purposes is ancillary to the other. Refer to Appendix D for guidance on whether a function should be regarded as ancillary or not.

#### Places of special fire hazard

**9.12** Every place of special fire hazard (see Appendix E) should be enclosed with fire-resisting construction; see Table A1, Item 13.

**Note:** Any such walls and floors are not compartment walls and compartment floors.

#### Flats

**9.13** In buildings containing flats, the following should be constructed as compartment walls or compartment floors:

- a. every floor (unless it is within a flat, i.e. between one storey and another within one individual dwelling); and
- b. every wall separating a flat from any other part of the building; and

## Section 9

**Note:** Any other part of the building does not include an external balcony/deck access.

- c. every wall enclosing a refuse storage chamber.

**9.14** Blocks of flats with a floor more than 30m above ground level should be fitted with a sprinkler system in accordance with section 2.

**Note:** Sprinklers need only be provided within the individual flats, they are not required in the common areas such as stairs, corridors or landings.

### Institutional buildings including health care

**9.15** All floors should be constructed as compartment floors.

**9.16** Paragraphs 4.41 to 4.52 give guidance on the provisions for compartment walls in care homes utilising progressive horizontal evacuation.

### Other residential buildings

**9.17** All floors should be constructed as compartment floors.

### Non-residential buildings

**9.18** The following walls and floors should be constructed as compartment walls and compartment floors in buildings of a non-residential purpose group (i.e. Office, Shop and Commercial, Assembly and Recreation, Industrial, Storage or Other non-residential):

- a. every wall needed to sub-divide the building to observe the size limits on compartments given in Table 12 (see Diagram 28a);
- b. every floor, if the building or separated part (see paragraph 9.22) of the building, has a storey with a floor at a height of more than 30m above ground level (see Diagram 28b);
- c. the floor of the ground storey if the building has one or more basements (see Diagram 28c), with the exception of small premises (see paragraph 4.1);
- d. the floor of every basement storey (except the lowest floor) if the building, or separated part (see paragraph 9.19), has a basement at a depth of more than 10m below ground level (see Diagram 28d);
- e. if the building forms part of a shopping complex, every wall and floor described in Section 6 of BS 5588-0:1991 *Fire precautions in the design, construction and use of buildings, Code of practice for shopping complexes* as needing to be constructed to the standard for a compartment wall or compartment floor; and
- f. if the building comprises Shop and Commercial, Industrial or Storage premises, every wall or floor provided to divide a building into separate occupancies, (i.e. spaces used by different organisations whether they fall within the same Purpose Group or not).

**Note:** See also the provision in paragraph 6.58 for store rooms in shops to be separated from retail areas by fire-resisting construction to the standard given in Table A1.



Section 9

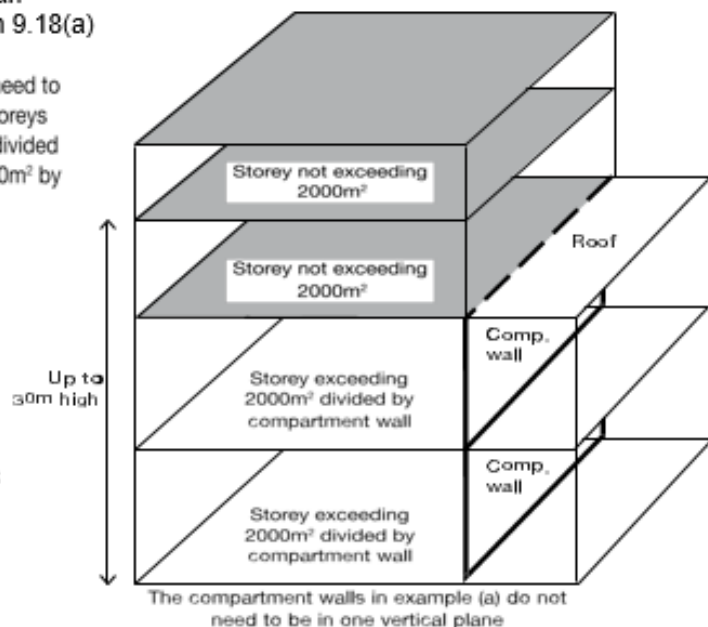
**9.19** In a two storey building in the Shop and Commercial or Industrial Purpose Groups, where the use of the upper storey is ancillary to the use of the ground storey, the ground storey may be treated as a single storey building for fire compartmentation purposes, provided that:

- the area of the upper storey does not exceed 20% of the area of the ground storey, or 500m<sup>2</sup>, whichever is less;
- the upper storey is compartmented from the lower one; and
- there is a means of escape from the upper storey that is independent of the routes from the lower storey.

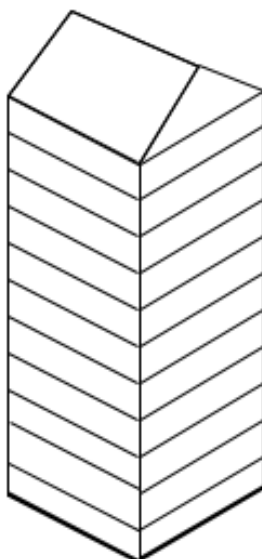
**Diagram 28** Compartment floors: illustration of guidance in paragraph 9.18

**A.** Example of compartmentation in an un sprinklered shop see paragraph 9.18(a)

None of the floors in this case would need to be compartment floors, but the two storeys exceeding 2000m<sup>2</sup> would need to be divided into compartments not more than 2000m<sup>2</sup> by compartment walls.



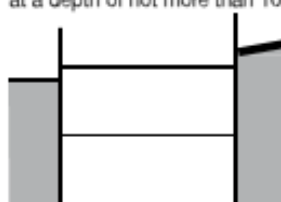
**B.** Compartmentation in tall Buildings see paragraph 9.18(b)



In a building over 30m in height all storeys should be separated by compartment floors. For advice on the special conditions in atrium buildings see BS 5588-7

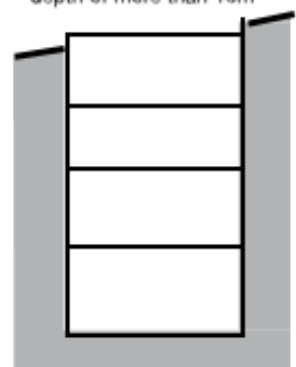
**C. SHALLOW BASEMENTS**

See paragraph 9.18(c)  
Only the floor of the ground storey need be a compartment floor if the lower basement is at a depth of not more than 10m



**D. DEEP BASEMENTS**

See paragraph 9.18(d)  
All basement storeys to be separated by compartment floors if any storey is at a depth of more than 10m



Section 9

<b>Table 12 Maximum dimensions of building or compartment (non-residential buildings)</b>				
<b>Purpose Group of building or part</b>	<b>Height of floor of top storey above ground level (m)</b>	<b>Floor area of any one storey in the building or any one storey in a compartment (m<sup>2</sup>)</b>		
			<b>In multi-storey buildings</b>	<b>In single-storey buildings</b>
Office	No limit		No limit	No limit
Assembly and recreation Shop and commercial				
a. Shops – not sprinklered	No limit		2000	2000
Shops – sprinklered <sup>(1)</sup>	No limit		4000	No limit
b. Elsewhere – not sprinklered	No limit		2000	No limit
Elsewhere – sprinklered <sup>(1)</sup>	No limit		4000	No limit
Industrial <sup>(2)</sup>				
Not sprinklered	Not more than 18 More than 18		7000 2000 <sup>(3)</sup>	No limit N/A
Sprinklered <sup>(1)</sup>	Not more than 18 More than 18		14,000 4000 <sup>(3)</sup>	No limit N/A
<b>Height of floor of top storey above ground level (m)</b>	<b>Maximum compartment volume m<sup>3</sup></b>		<b>Maximum floor area (m<sup>2</sup>)</b>	<b>Maximum height (m) <sup>(4)</sup></b>
	<b>Multi storey buildings</b>		<b>Single storey buildings</b>	
a. Storage (2) and other non-residential: Car park for light vehicles	No limit	No limit	No limit	No limit
b. Any other building or part: Not sprinklered	Not more than 18 More than 18	20,000 4000 <sup>(3)</sup>	20,000 N/A	18 N/A
Sprinklered <sup>(1)</sup>	Not more than 18 More than 18	40,000 8000 <sup>(3)</sup>	No limit	No limit

**Notes:**

1. 'Sprinklered' means that the building is fitted throughout with an automatic fire suppression system in accordance with Section 2.
2. There may be additional limitations on floor area and/or automatic fire suppression provisions in certain industrial and storage uses under other legislation, for example in respect of storage of LPG and certain chemicals.
3. This reduced limit applies only to storeys that are more than 18m above ground level. Below this height the higher limit applies.
4. Compartment height is measured from finished floor level to underside of roof or ceiling.

## Section 9

# Construction of compartment walls and compartment floors

## General

**9.20** Every compartment wall and compartment floor should:

- a. form a complete barrier to fire between the compartments they separate; and
- b. have the appropriate fire resistance as indicated in Appendix A, Tables A1 and A2.

**Note 1:** Timber beams, joists, purlins and rafters may be built into or carried through a masonry or concrete compartment wall if the openings for them are kept as small as practicable and then fire-stopped. If trussed rafters bridge the wall, they should be designed so that failure of any part of the truss due to a fire in one compartment will not cause failure of any part of the truss in another compartment.

**Note 2:** Where services are incorporated within the construction that could provide a potential source of ignition, care should be taken to ensure the risk of fire developing and spreading prematurely into adjacent compartments is controlled.

## Compartment walls between buildings

**9.21** Compartment walls that are common to two or more buildings should run the full height of the building in a continuous vertical plane. Thus adjoining buildings should only be separated by walls, not floors.

## Separated parts of buildings

**9.22** Compartment walls used to form a separated part of a building (so that the separated parts can be assessed independently for the purpose of determining the appropriate standard of fire resistance) should run the full height of the building in a continuous vertical plane. The two separated parts can have different standards of fire resistance.

## Other compartment walls

**9.23** Compartment walls not described in paragraphs 9.21 and 9.22 should run the full height of the storey in which they are situated.

**9.24** Compartment walls in a top storey beneath a roof should be continued through the roof space (see definition of compartment in Appendix E).

## Junction of compartment wall or compartment floor with other walls

**9.25** Where a compartment wall or compartment floor meets another compartment wall or an external wall, the junction should maintain the fire resistance of the compartmentation. Fire-stopping should meet the provisions of paragraphs 11.17 to 11.19.

**9.26** At the junction of a compartment floor with an external wall that has no fire resistance (such as a curtain wall) the external wall should be restrained at floor level to reduce the movement of the wall away from the floor when exposed to fire.

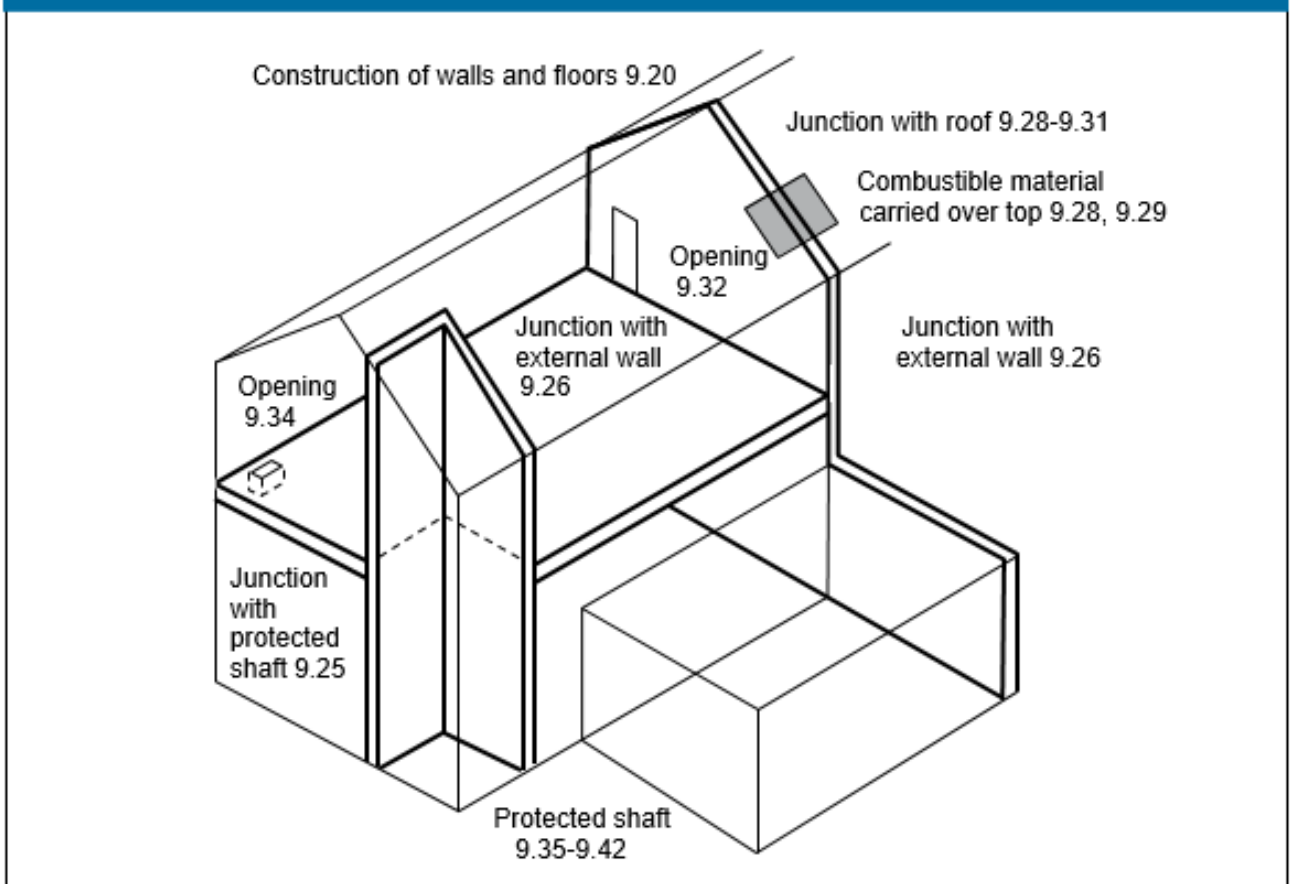
## Section 9

**9.27** Compartment walls should be able to accommodate the predicted deflection of the floor above by either:

- a. having a suitable head detail between the wall and the floor, that can deform but maintain integrity when exposed to a fire; or
- b. the wall may be designed to resist the additional vertical load from the floor above as it sags under fire conditions and thus maintain integrity.

**Note:** Where compartment walls are located within the middle half of a floor between vertical supports, the predicted deflection may be assumed to be 40mm unless a smaller value can be justified by assessment. Outside this area the limit can be reduced linearly to zero at the supports. For steel beams that do not have the required fire resistance, reference should be made to SCI Publication 288 *Fire safe design: A new approach to multi-storey steel-framed buildings* (Second Edition) 2000 (ISBN: 1 85942 169 5).

**Diagram 29** Compartment walls and compartment floors with reference to relevant paragraphs in Section 9



## Section 9

### Junction of compartment wall with roof

- 9.28** A compartment wall should be taken up to meet the underside of the roof covering or deck, with fire-stopping where necessary at the wall/ roof junction to maintain the continuity of fire resistance. The compartment wall should also be continued across any eaves cavity (see paragraph 9.20a).
- 9.29** If a fire penetrates a roof near a compartment wall there is a risk that it will spread over the roof to the adjoining compartment. To reduce this risk and subject to paragraph 9.30, a zone of the roof 1500mm wide on either side of the wall should have a covering of designation AA, AB or AC (see Appendix A, paragraph 6) on a substrate or deck of a material of limited combustibility, as set out in Diagram 30a.

**Note:** Thermoplastic rooflights which, by virtue of paragraph 15.7, are regarded as having an AA (*National class*) designation or  $B_{ROOF}(t4)$  (*European class*) classification are **not** suitable for use in the zone described above.

- 9.30** In buildings not more than 15m high, of the purpose groups listed below, combustible boarding used as a substrate to the roof covering, wood wool slabs, or timber tiling battens, may be carried over the compartment wall provided that they are fully bedded in mortar or other suitable material over the width of the wall (see Diagram 30b). This applies to, buildings or compartments in Residential use (other than Institutional), Office buildings, Assembly and Recreation buildings.

**Note:** Double-skinned insulated roof sheeting, with a thermoplastic core, should incorporate a band of material of limited combustibility at least 300mm wide centred over the wall.

- 9.31** As an alternative to paragraphs 9.29 or 9.30 the compartment wall may be extended up through the roof for a height of at least 375mm above the top surface of the adjoining roof covering. Where there is a height difference of at least 375mm between two roofs or where the roof coverings on either side of the wall are AA, AB or AC this height may be reduced to 200mm (see Diagram 30c).

### Openings in compartmentation

#### Openings in compartment walls separating buildings or occupancies

- 9.32** Any openings in a compartment wall which is common to two or more buildings, or between different occupancies in the same building, should be limited to those for:
- a door which is needed to provide a means of escape in case of fire and which has the same fire resistance as that required for the wall (see Appendix B, Table B1) and is fitted in accordance with the provisions of Appendix B; and
  - the passage of a pipe which meets the provisions in Section 11.

## Section 9

### Doors

**9.33** Information on fire doors may be found in Appendix B.

### Openings in other compartment walls or in compartment floors

**9.34** Openings in compartment walls (other than those described in paragraph 9.32) or compartment floors should be limited to those for:

- a. doors which have the appropriate fire resistance given in Appendix B, Table B1 and are fitted in accordance with the provisions of Appendix B;
- b. the passage of pipes, ventilation ducts, service cables, chimneys, appliance ventilation ducts or ducts encasing one or more flue pipes, which meet the provisions in Section 10;
- c. refuse chutes of non-combustible construction;
- d. atria designed in accordance with BS 5588-7:1997; and
- e. protected shafts which meet the relevant provisions below.

### Protected shafts

**9.35** Any stairway or other shaft passing directly from one compartment to another should be enclosed in a protected shaft so as to delay or prevent the spread of fire between compartments.

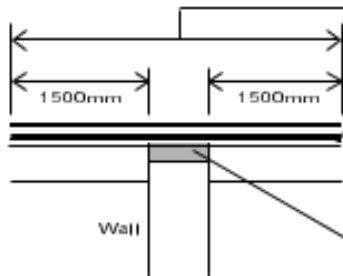
There are additional provisions in Sections 3 to 6 for protected shafts that are protected stairways and in Section 18 if the stairway also serves as a firefighting stair.

Section 9

**Diagram 30 Junction of compartment wall with roof**

See paras 9.28-9.31

**a. ANY BUILDING OR COMPARTMENT**



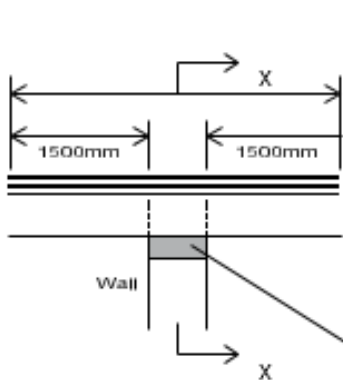
Roof covering over this distance to be designated AA, AB or AC on deck of material of limited combustibility. Roof covering and deck could be composite structure. E.g. profiled steel cladding.

Double-skinned insulated roof sheeting should incorporate a band of material of limited combustibility at least 300mm wide centred over the wall.

If roof support members pass through the wall, fire protection to these members for a distance of 1500mm on either side of the wall may be needed to delay distortion at the junction (see note to paragraph 9.20).

Resilient fire-stopping to be carried up to underside of roof covering e.g. roof tiles.

**b. RESIDENTIAL (NOT INSTITUTIONAL) OFFICE OR ASSEMBLY USE AND NOT MORE THAN 15M HIGH**



Roof covering to be designated AA, AB or AC for at least this distance.

Boarding (used as a substrate), wood wool slabs or timber tiling battens may be carried over the wall provided that they are fully bedded in mortar (or other no less suitable material) where over the wall.

Thermoplastic insulation materials should not be carried over the wall.

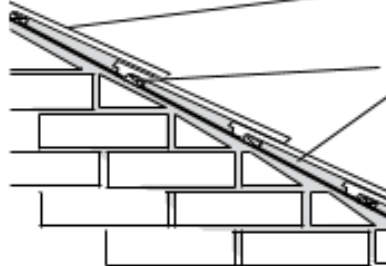
Double-skinned insulated roof sheeting with a thermoplastic core should incorporate a band of material of limited combustibility at least 300mm wide centred over the wall.

Sarking felt may also be carried over the wall.

If roof support members pass through the wall, fire protection to these members for a distance of 1500mm on either side of the wall may be needed to delay distortion at the junction (see note to paragraph 9.20).

Fire-stopping to be carried up to underside of roof covering, boarding or slab.

**Section X-X**



Roof covering to be designated AA, AB or AC for at least 1500mm either side of wall.

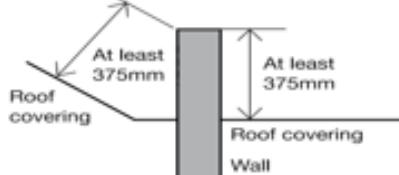
Roofing battens and sarking felt may be carried over the wall.

Fire-stopping to be carried up to underside of roof covering. Above and below sarking felt.

**Notes**

1. Fire-stopping should be carried over the full thickness of the wall.
2. Fire-stopping should be extended into any eaves.
3. The compartment wall need not necessarily be constructed of masonry.

**c. ANY BUILDING OR COMPARTMENT**



The wall should be extended up through the roof for a height of at least 375mm above the top surface of the adjoining roof covering.

Where there is a height difference of at least 375mm between two roofs or where the roof coverings on either side of the wall are AA, AB or AC the height of the upstand/parapet wall above the highest roof may be reduced to 200mm.

## Section 9

### Uses for protected shafts

**9.36** The uses of protected shafts should be restricted to stairs, lifts, escalators, chutes, ducts and pipes. Sanitary accommodation and washrooms may be included in protected shafts.

### Construction of protected shafts

**9.37** The construction enclosing a protected shaft (see Diagram 31) should:

- a. form a complete barrier to fire between the different compartments which the shaft connects;
- b. have the appropriate fire resistance given in Appendix A, Table A1, except for uninsulated glazed screens which meet the provisions of paragraph 9.38; and
- c. satisfy the provisions about their ventilation and the treatment of openings in paragraphs 9.41 and 9.42.

### Uninsulated glazed screens to protected shafts

**9.38** If the conditions given below and described in Diagram 32 are satisfied, an uninsulated glazed screen may be incorporated in the enclosure to a protected shaft between a stair and a lobby or corridor which is entered from the stair. The conditions to be satisfied are:

- a. the standard of fire resistance for the stair enclosure is not more than 60 minutes; and
- b. the glazed screen:
  - i. has at least 30 minutes fire resistance in terms of integrity; and
  - ii. meets the guidance in Appendix A, Table A4, on the limits on areas of uninsulated glazing; and
- c. the lobby or corridor is enclosed to at least a 30 minute standard.

**9.39** Where the measures in Diagram 32 to protect the lobby or corridor are not provided, the enclosing walls should comply with Appendix A, Table A1 (item 8c) and the doors with the guidance in Appendix A, Table A4.

### Pipes for oil or gas and ventilation ducts in protected shafts

**9.40** If a protected shaft contains a stair and/or a lift, it should not also contain a pipe conveying oil (other than in the mechanism of a hydraulic lift) or contain a ventilating duct (other than a duct provided for the purposes of pressurizing the stairway to keep it smoke free; or a duct provided solely for ventilating the stairway).

Any pipe carrying natural gas or LPG in such a shaft should be of screwed steel or of all welded steel construction, installed in accordance with the *Pipelines Safety Regulations 1996*, SI 1996 No 825 and the *Gas Safety (Installation and use) Regulations 1998*, SI 1998 No 2451.

**Note:** A pipe is not considered to be contained within a protected shaft if the pipe is completely separated from that protected shaft by fire-resisting construction.



## Section 9

### Ventilation of protected shafts conveying gas

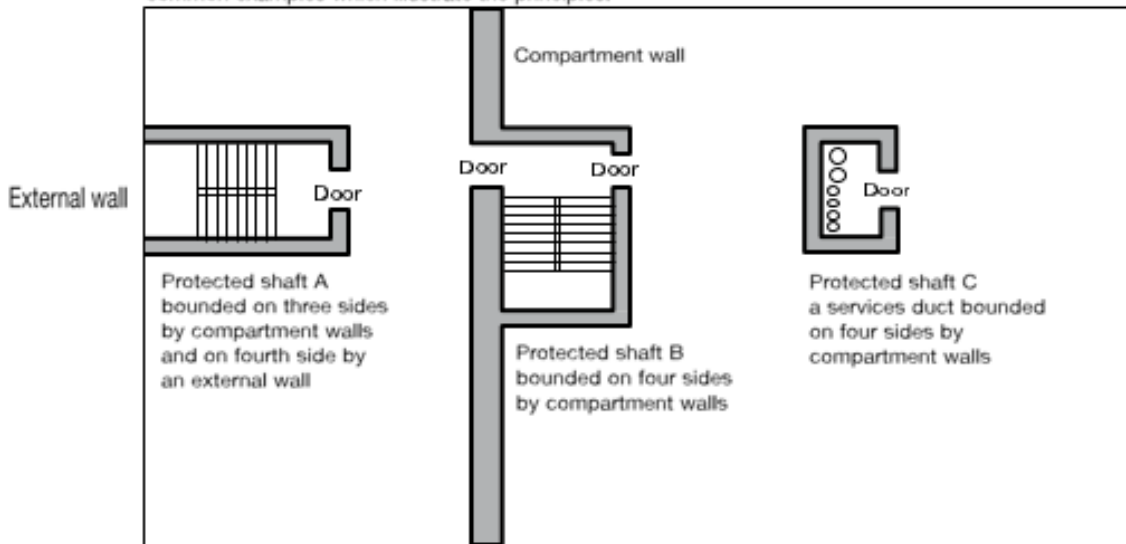
**9.41** A protected shaft conveying piped flammable gas should be adequately ventilated direct to the outside air by ventilation openings at high and low level in the shaft.

Any extension of the storey floor into the shaft should not compromise the free movement of air over the entire length of the shaft. Guidance on such shafts, including sizing of the ventilation openings, is given in BS 8313:1997.

#### Diagram 31 Protected shafts

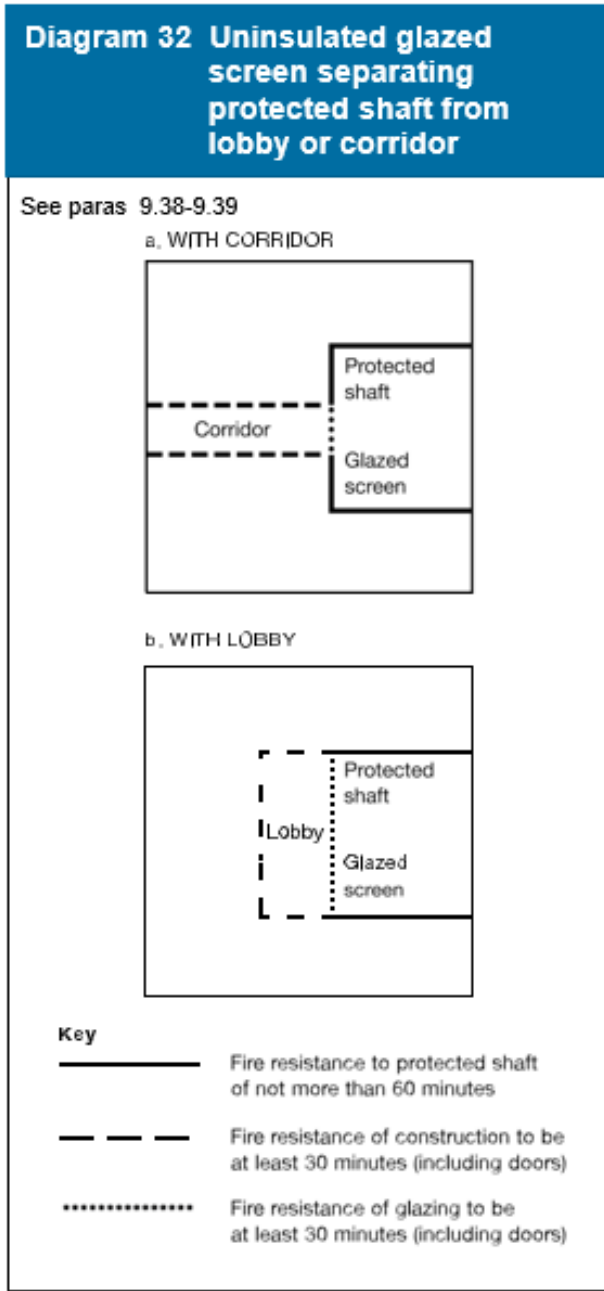
See paras 9.35-9.37

Protected shafts provide for the movement of people (e.g. stairs, lifts), or for passage of goods, air or services such as pipes or cables between different compartments. The elements enclosing the shaft (unless formed by adjacent external walls) are compartment walls and floors. The diagram shows three common examples which illustrate the principles.



The shaft structure (including any openings) should meet the relevant provisions for: compartment walls (see paragraphs 9.20 to 9.34), external walls (see Sections 13 and 14 and Diagram 24)

Section 9



## Section 9

### Openings into protected shafts

**9.42** Generally an external wall of a protected shaft does not need to have fire resistance.

However, there are some provisions for fire resistance of external walls of firefighting shafts in BS 5588-5:2004, which is the relevant guidance called up by paragraph 18.11 to 18.13 and of external walls to protected stairways (which may also be protected shafts) in paragraph 6.24.

Openings in other parts of the enclosure to a protected shaft should be limited as follows:

- a. Where part of the enclosure to a protected shaft is a wall common to two or more buildings, only the following openings should be made in that wall:
  - i. a door which is needed to provide a means of escape in case of fire; and which has the same fire resistance as that required for the wall (see Appendix B, Table B1); and is fitted in accordance with the provisions of Appendix B; and/or
  - ii. the passage of a pipe which meets the provisions in Section 11.
- b. Other parts of the enclosure (other than an external wall) should only have openings for:
  - i. doors which have the appropriate fire resistance given in Appendix B, Table B1 and are fitted in accordance with the provisions of Appendix B;
  - ii. the passage of pipes which meet the provisions in Section 11;
  - iii. inlets to, outlets from and openings for a ventilation duct, (if the shaft contains or serves as a ventilating duct) which meet the provisions in Section 11; and/or
  - iv. the passage of lift cables into a lift machine room (if the shaft contains a lift). If the machine room is at the bottom of the shaft, the openings should be as small as practicable.

## Section 10

## B3

# Concealed spaces (cavities)

### Introduction

**10.1** Concealed spaces or cavities in the construction of a building provide a ready route for smoke and flame spread. This is particularly so in the case of voids in, above and below the construction of a building, e.g. walls, floors, ceilings and roofs. As any spread is concealed, it presents a greater danger than would a more obvious weakness in the fabric of the building.

### Provision of cavity barriers

**10.2** Provisions for cavity barriers are given below for specified locations. The provisions necessary to restrict the spread of smoke and flames through cavities are broadly for the purpose of sub-dividing:

- a. cavities, which could otherwise form a pathway around a fire-separating element and closing the edges of cavities; therefore reducing the potential for unseen fire spread; and

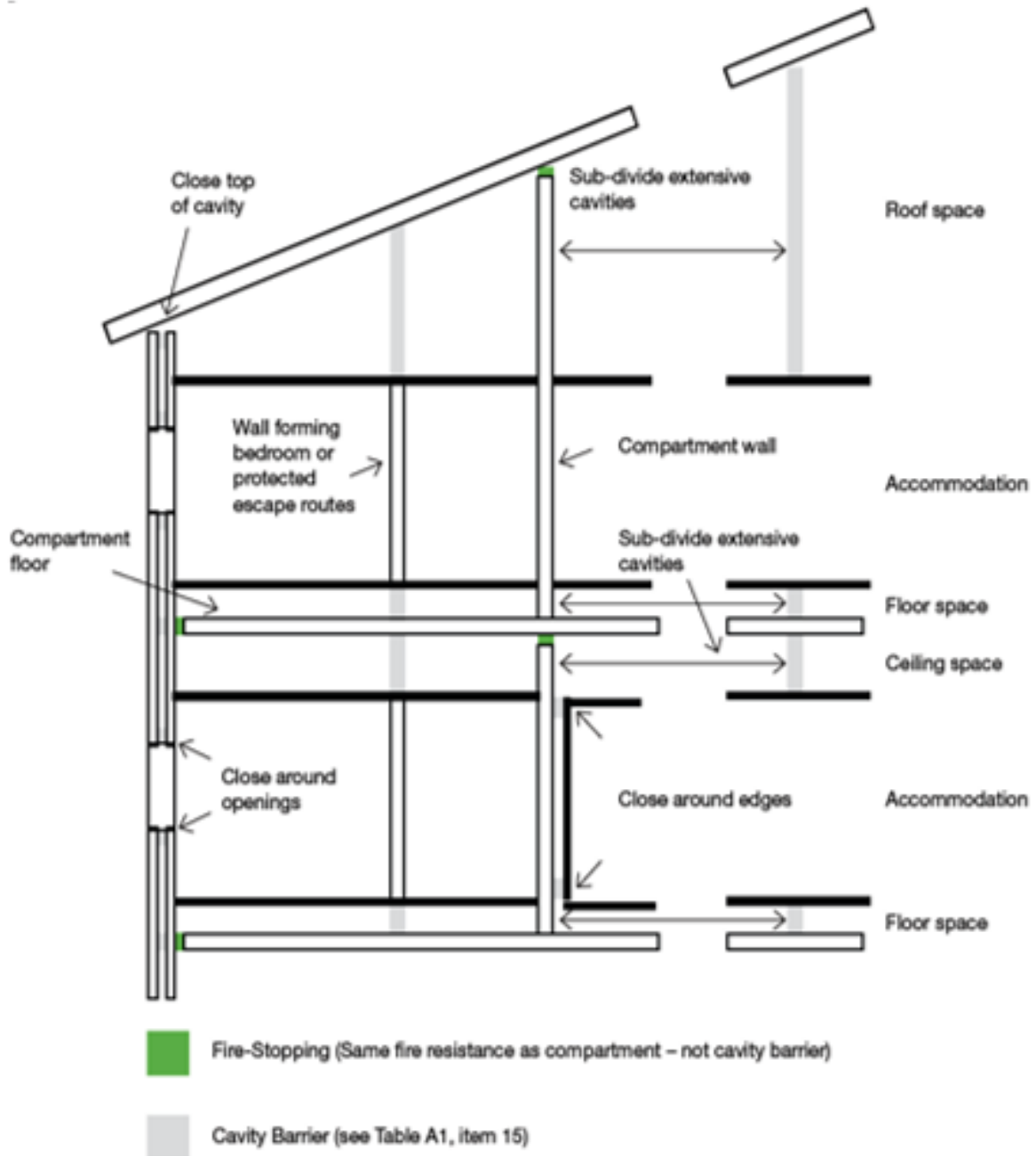
**Note:** These should not be confused with fire-stopping details, see Section 11 and Diagram 33 (see also paragraphs 10.3 to 10.7).

- b. extensive cavities (see paragraphs 10.8 to 10.12). Consideration should also be given to the construction and fixing of cavity barriers provided for these purposes and the extent to which openings in them should be protected. For guidance on these issues, see paragraphs 10.13 to 10.16 respectively.

Section 10

**Diagram 33 Provisions for cavity barriers**

See para 10.2



## Section 10

### Pathways around fire-separating elements

#### Junctions and cavity closures

**10.3** Cavity barriers should be provided to close the edges of cavities, including around openings. Cavity barriers should also be provided:

- a. at the junction between an external cavity wall (except where the cavity wall complies with Diagram 34) and every compartment floor and compartment wall; and
- b. at the junction between an internal cavity wall (except where the cavity wall complies with Diagram 34) and every compartment floor, compartment wall, or other wall or door assembly which forms a fire-resisting barrier.

It is important to continue any compartment wall up through a ceiling or roof cavity to maintain the standard of fire resistance – therefore compartment walls should be carried up full storey height to a compartment floor or to the roof as appropriate, see paragraphs 9.21 to 9.24. It is therefore not appropriate to complete a line of compartmentation by fitting cavity barriers above them.

#### Protected escape routes

**10.4** For a protected escape route, a cavity that exists **above or below** any fire-resisting construction because the construction is not carried to full storey height or, in the case of a top storey, to the underside of the roof covering, should either be:

- a. fitted with cavity barriers on the line of the enclosure(s) to the protected escape route; or
- b. for cavities above the fire-resisting construction, enclosed on the lower side by a fire-resisting ceiling which extends throughout the building, compartment or separated part (see Diagram 35).

#### Double-skinned corrugated or profiled roof sheeting

**10.5** Cavity Barriers need not be provided between double-skinned corrugated or profiled insulated roof sheeting, if the sheeting is a material of limited combustibility and both surfaces of the insulating layer have a surface spread of flame of at least Class 0 or 1 (National class) or Class C- s3, d2 or better (European class) (see Appendix A) and make contact with the inner and outer skins of cladding (see Diagram 36).

**Note:** See also paragraph 9.29 Note 2 regarding the junction of a compartment wall with a roof.

**Note:** When a classification includes “s3, d2”, this means that there is no limit set for smoke production and/or flaming droplets/particles.

#### Cavities affecting alternative escape routes

**10.6** Cavity barriers may be needed where corridors are to be sub-divided to prevent alternative escape routes being simultaneously affected by fire and/or smoke (see paragraph 4.26 and Diagram 16).

## Section 10

### Separation of bedrooms

**10.7** In Institutional and Other Residential buildings, a cavity that exists above or below partitions between bedrooms because the enclosures are not carried to full storey height, or, (in the case of the top storey) to the underside of the roof covering, should either be:

- a. fitted with cavity barriers on the line of the partitions; or
- b. for cavities above the partitions, enclosed on the lower side by a fire-resisting ceiling which extends throughout the building, compartment or separated part.

### Extensive Cavities

**10.8** Cavity barriers should be used to sub-divide any cavity, including any roof space, so that the distance between cavity barriers does not exceed the dimensions given in Table 13.

### Maximum dimensions of concealed spaces

**10.9** Table 13 sets out maximum dimensions for undivided concealed spaces. With the exceptions given in paragraphs 10.10 to 10.12, extensive concealed spaces should be sub-divided to comply with the dimensions in Table 13.

**10.10** The provisions in Table 13 do not apply to any cavity described below:

- a. in a wall which should be fire-resisting only because it is loadbearing;
- b. in a masonry or concrete external cavity wall shown in Diagram 34;
- c. in any floor or roof cavity above a fire-resisting ceiling, as shown in Diagram 35 and which extends throughout the building or compartment subject to a 30m limit on the extent of the cavity; or
- d. formed behind the external skin of an external cladding system with a masonry or concrete inner leaf at least 75mm thick, or by overcladding an existing masonry (or concrete) external wall, or an existing concrete roof, provided that the cavity does not contain combustible insulation and the building is not put to a residential or institutional use; or
- e. between double-skinned corrugated or profiled insulated roof sheeting, if the sheeting is a material of limited combustibility and both surfaces of the insulating layer have a surface spread of flame of at least Class 0 or 1 (National class) or Class C-s3, d2 or better (European class) (see Appendix A) and make contact with the inner and outer skins of cladding (see Diagram 36); or
- f. below a floor next to the ground or oversite concrete, if the cavity is less than 1000mm in height or if the cavity is not normally accessible by persons, unless there are openings in the floor such that it is possible for combustibles to accumulate in the cavity (in which case cavity barriers should be provided and access should be provided to the cavity for cleaning).

**Note:** When a classification includes “s3, d2”, this means that there is no limit set for smoke production and/or flaming droplets/particles.

**Section 10**

**Table 13 Maximum dimensions of cavities in non-domestic buildings (Purpose Groups 2-7)**

Location of cavity	Class of surface/product exposed in cavity (excluding the surface of any pipe, cable or conduit, or any insulation to any pipe)		Maximum dimensions in any direction (m)
	National class	European class	
Between roof and a ceiling	Any	Any	20
Any other cavity	Class 0 or Class 1	Class A1 or Class A2-s3, d2 or Class B-s3, d2 or Class C-s3, d2	20
	Not Class 0 or Class 1	Not any of the above classes	10

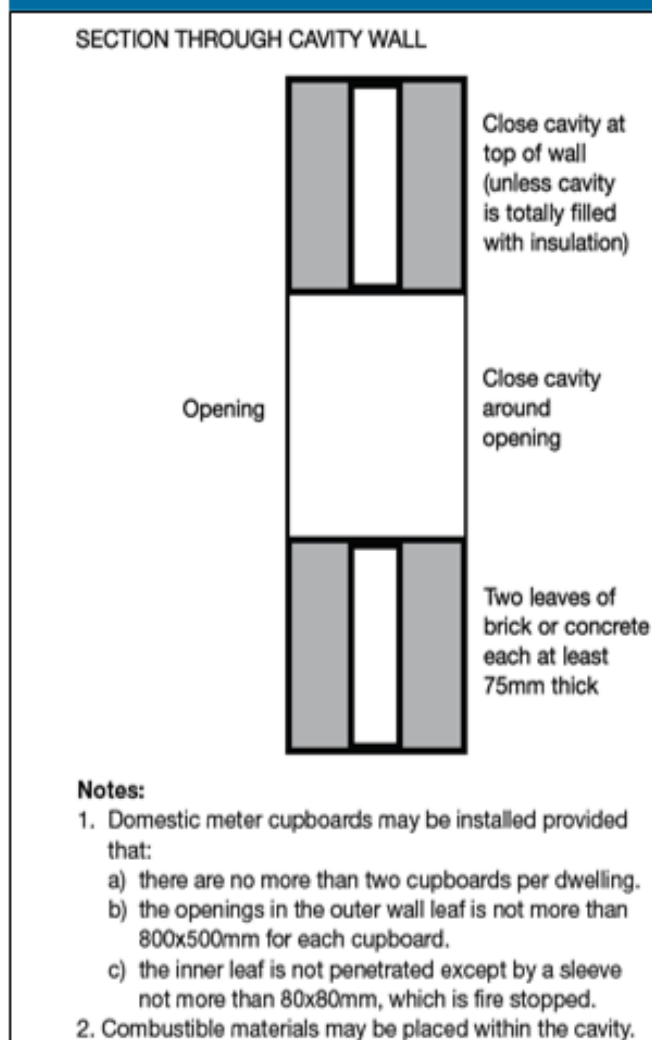
**Notes:**

1. Exceptions to these provisions are given in paragraphs 10.10 to 10.12.
2. The national classifications do not automatically equate with the equivalent classifications in the European column, therefore, products cannot typically assume a European class unless they have been tested accordingly.
3. When a classification includes “s3, d2”, this means that there is no limit set for smoke production and/or flaming droplets/particles

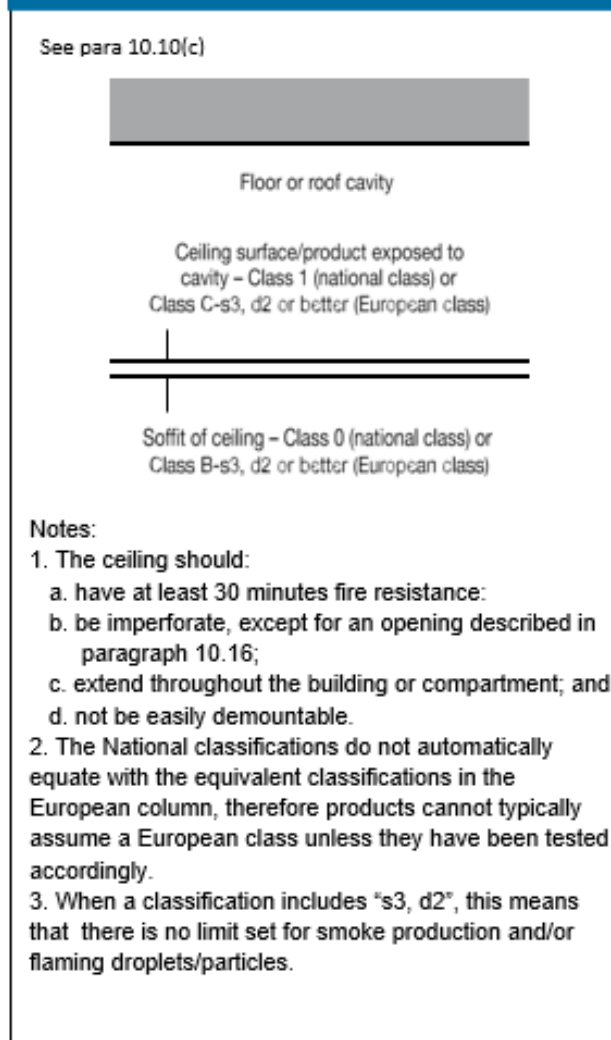


Section 10

**Diagram 34 Cavity wall excluded from provisions for cavity barriers**



**Diagram 35 Fire-resisting ceiling below concealed space**

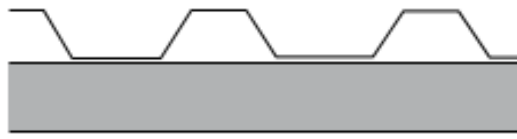


Section 10

**Diagram 36 Provisions for cavity barriers in double-skinned insulated roof sheeting**

See para 10.10(e)

a. ACCEPTABLE WITHOUT CAVITY BARRIERS



The insulation should make contact with both skins of sheeting. See also Diagram 30a regarding the need for a fire break where such roofs pass over the top of a compartment wall.



b. CAVITY BARRIERS NECESSARY

**10.11** Where any single room with a ceiling cavity or underfloor service void exceeds the dimensions given in Table 13, cavity barriers need only be provided on the line of the enclosing walls/ partitions of that room, subject to:

- a. the cavity barriers being no more than 40m apart; and
- b. the surface of the material/product exposed in the cavity being Class 0 or Class 1 (National class) or Class C-s3, d2 or better (European class).

**Note:** When a classification includes “s3, d2”, this means that there is no limit set for smoke production and/or flaming droplets/particles.

**10.12** Where the concealed space is an undivided area which exceeds 40m (this may be in both directions on plan) there is no limit to the size of the cavity if:

- a. the room and the cavity together are compartmented from the rest of the building;
- b. an automatic fire detection and alarm system meeting the relevant recommendations of BS 5839-1:2002 is fitted in the building. Detectors are only required in the cavity to satisfy BS 5839-1.
- c. the cavity is used as a plenum and the recommendations about recirculating air distribution systems in BS 5588-9:1999 are followed;

## Section 10

- d. the surface of the material/product used in the construction of the cavity which is exposed in the cavity is Class 0 (National class) or Class B-s3, d2 or better (European class) and the supports and fixings in the cavity are of non-combustible construction;
- e. the flame spread rating of any pipe insulation system is Class 1 or Class C-s3, d2 or better (European class) (see Appendix A);
- f. any electrical wiring in the void is laid in metal trays, or in metal conduit; and
- g. any other materials in the cavity are of limited combustibility or Class A2 or better (European class) (see Appendix A).

**Note:** When a classification includes “s3, d2”, this means that there is no limit set for smoke production and/or flaming droplets/particles.

### Construction and fixings for cavity barriers

**10.13** Every cavity barrier should be constructed to provide at least 30 minutes fire resistance. It may be formed by any construction provided for another purpose if it meets the provisions for cavity barriers (see Appendix A, Table A1, item 15).

Cavity barriers in a stud wall or partition, or provided around openings may be formed of:

- a. steel at least 0.5mm thick;
- b. timber at least 38mm thick;
- c. polythene-sleeved mineral wool, or mineral wool slab, in either case under compression when installed in the cavity; or
- d. calcium silicate, cement-based or gypsum-based boards at least 12mm thick.

**Note:** Cavity barriers provided around openings may be formed by the window or door frame if the frame is constructed of steel or timber of the minimum thickness in a) or b) above as appropriate.

**10.14** A cavity barrier should, wherever possible, be tightly fitted to a rigid construction and mechanically fixed in position. Where this is not possible (for example, in the case of a junction with slates, tiles, corrugated sheeting or similar materials) the junction should be fire-stopped. Provisions for fire-stopping are set out in Section 11.

**10.15** Cavity barriers should also be fixed so that their performance is unlikely to be made ineffective by:

- a. movement of the building due to subsidence, shrinkage or temperature change and movement of the external envelope due to wind;
- b. collapse in a fire of any services penetrating them;
- c. failure in a fire of their fixings (but see note below); and
- d. failure in a fire of any material or construction which they abut. (For example, if a suspended ceiling is continued over the top of a fire-resisting wall or partition and direct connection is made between the ceiling and the cavity barrier above the line of the wall or partition, premature failure of the cavity

## Section 10

barrier can occur when the ceiling collapses. However, this may not arise if the ceiling is designed to provide fire protection of 30 minutes or more.)

**Note:** Where cavity barriers are provided in roof spaces, the roof members to which they are fitted are not expected to have any fire resistance – for the purpose of supporting the cavity barrier(s).

**10.16** Any openings in a cavity barrier should be limited to those for:

- a. doors which have at least 30 minutes fire resistance (see Appendix B, Table B1, item 8) and are fitted in accordance with the provisions of Appendix B;
- b. the passage of pipes which meet the provisions in Section 11;
- c. the passage of cables or conduits containing one or more cables;
- d. openings fitted with a suitably mounted automatic fire damper (see paragraphs 11.11 to 11.15); and
- e. ducts which (unless they are fire-resisting) are fitted with a suitably mounted automatic fire damper where they pass through the cavity barrier.

**Note:** If a cavity barrier is provided above a partition separating bedrooms in accordance with paragraph 10.7 which do not need to be fire resisting partitions then a. to e need not apply. However, openings in the barrier should be kept to a minimum and any penetrations should be sealed to restrict the passage of smoke.

## Section 11

## B3

# Protection of openings and fire stopping

### Introduction

- 11.1** Sections 9 and 10 make provisions for fire-separating elements and set out the circumstances in which there may be openings in them. This section deals with the protection of openings in such elements.
- 11.2** If a fire-separating element is to be effective, every joint or imperfection of fit, or opening to allow services to pass through the element, should be adequately protected by sealing or fire-stopping so that the fire resistance of the element is not impaired.
- 11.3** The measures in this Section are intended to delay the passage of fire. They generally have the additional benefit of retarding smoke spread, but the tests specified in Appendix A for integrity does not directly stipulate criteria for the passage of smoke.
- 11.4** Detailed guidance on door openings and fire doors is given in Appendix B.

### Openings for pipes

- 11.5** Pipes which pass through a fire-separating element (unless the pipe is in a protected shaft), should meet the appropriate provisions in alternatives A, B or C below.

#### Alternative A: Proprietary seals (any pipe diameter)

- 11.6** Provide a proprietary sealing system which has been shown by test to maintain the fire resistance of the wall, floor or cavity barrier.

#### Alternative B: Pipes with a restricted diameter

- 11.7** Where a proprietary sealing system is not used, fire-stopping may be used around the pipe, keeping the opening as small as possible. The nominal internal diameter of the pipe should not be more than the relevant dimension given in Table 14.

The diameters given in Table 14 for pipes of specification (b) used in situation (2) assumes that the pipes are part of an above ground drainage system and are enclosed as shown in Diagram 38 if they are not, the smaller diameter given for situation (3) should be used.

#### Alternative C: Sleeving

- 11.8** A pipe of lead, aluminium, aluminium alloy, fibre-cement or uPVC, with a maximum nominal internal diameter of 160mm, may be used with a sleeving of non-combustible pipe as shown in Diagram 37. The specification for non-combustible and uPVC pipes is given in the notes to Table 14.

Section 11

**Table 14 Maximum nominal internal diameter of pipes passing through a compartment wall/floor (see paragraph 11.5 onwards)**

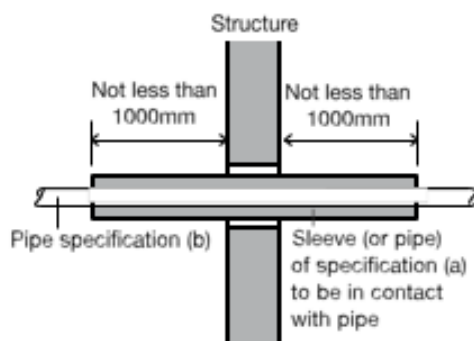
Situation	Pipe material and maximum nominal internal diameter (mm)		
	(a) Non-combustible material <sup>(1)</sup>	(b) Lead, aluminium, aluminium alloy, uPVC <sup>(2)</sup> , fibre cement	(c) Any other material
1. Structure (but not a wall separating buildings) enclosing a protected shaft which is not a stairway or a lift shaft	160	110	40
2. Compartment wall or compartment floor between flats	160	160 (stack pipe) <sup>(3)</sup> 110 (branch pipe) <sup>(3)</sup>	40
3. Any other situation	160	40	40

**Notes:**

1. Any non-combustible material (such as cast iron, copper or steel) which, if exposed to a temperature of 800°C, will not soften or fracture to the extent that flame or hot gas will pass through the wall of the pipe.
2. uPVC pipes complying with BS 4514:2001 and uPVC pipes complying with BS 5255:1989.
3. These diameters are only in relation to pipes forming part of an above-ground drainage system and enclosed as shown in Diagram 38. In other cases the maximum diameters against situation 3 apply.

**Diagram 37 Pipes penetrating structure**

See para 11.8, alternative method C



**Notes:**

- 1 Make the opening in the structure as small as possible and provide fire-stopping between pipe and structure.
- 2 See Table 14 for materials specification.

## Section 11

### Ventilation ducts, flues etc.

**11.9** Where air handling ducts pass through fire separating elements the integrity of those elements should be maintained.

There are three basic methods and these are:

- Method 1 Protection using fire dampers;
- Method 2 Protection using fire-resisting enclosures;
- Method 3 Protection using fire-resisting ductwork.

**11.10** Method 1 is not suitable for extract ductwork serving kitchens. This is due to the likely build up of grease within the duct which can adversely affect the effectiveness of any dampers.

Further information on fire-resisting ductwork is given in the ASFP Blue Book: *Fire resisting ductwork* (ISBN: 1 87040 926 4) published by the Association for Specialist Fire Protection and freely available from the ASFP website at [www.asfp.org.uk](http://www.asfp.org.uk).

### Fire dampers

**11.11** Fire dampers should be situated within the thickness of the fire-separating elements and be securely fixed. It is also necessary to ensure that, in a fire, expansion of the ductwork would not push the fire damper through the structure.

**11.12** Adequate means of access should be provided to allow inspection, testing and maintenance of both the fire damper and its actuating mechanism.

**11.13** Where the use of the building involves a sleeping risk, such as an hotel or residential care home, fire dampers should be actuated by smoke detector-controlled automatic release mechanisms, in addition to being actuated by thermally actuated devices.

However, in a situation where all occupants of the building can be expected to make an unaided escape and an L1 fire alarm system is installed in accordance with BS 5839-1:2002, the following exceptions may be made:

- a. If, on the detection of smoke, the alarm system signals the immediate evacuation of all the occupants of the building, then fire/smoke dampers are not needed; and
- b. If the building is divided into fire compartments and the alarm system is arranged to signal the immediate evacuation of the occupants of the fire compartment in which the fire has been detected, then smoke detector operated fire/smoke dampers need only be provided where ductwork enters or leaves the fire compartment.

**Note:** Fire dampers actuated only by fusible links are not suitable for protecting escape routes. However an ES classified fire and smoke damper which is activated by a suitable fire detection system may be used. See paragraph 11.15.

## Section 11

**11.14** Further guidance on the design and installation of mechanical ventilation and air-conditioning plant is given in BS 5720:1979 on ventilation and air-conditioning ductwork in BS 5588-9:1999.

Further information on fire and smoke-resisting dampers is given in the ASFP Grey Book: *Fire and smoke resisting dampers* (ISBN: 1 87040 924 8) published by the Association for Specialist Fire Protection and freely available from the ASFP website at [www.asfp.org.uk](http://www.asfp.org.uk).

**11.15** Fire dampers should be tested to BS EN 1366-2:1999 and be classified to BS EN 13501-3:2005. They should have an E classification equal to, or greater than, 60 minutes. Fire and smoke dampers should also be tested to BS EN 1366-2:1999 and be classified to BS EN 13501-3. They should have an ES classification equal to, or greater than, 60 minutes.

**Note 1:** Fire dampers tested using ad-hoc procedures based on BS 476 may only be appropriate for fan-off situations. In all cases, fire dampers should be installed as tested.

**Note 2:** Paragraphs 6.46 and 9.40 also deal with ventilation and air-conditioning ducts.

### Flues, etc.

**11.16** If a flue, or duct containing flues or appliance ventilation duct(s), passes through a compartment wall or compartment floor, or is built into a compartment wall, each wall of the flue or duct should have a fire resistance of at least half that of the wall or floor in order to prevent the by-passing of the compartmentation (see Diagram 39)

### Fire-stopping

**11.17** In addition to any other provisions in this document for fire-stopping:

- a. joints between fire-separating elements should be fire-stopped; and
- b. all openings for pipes, ducts, conduits or cables to pass through any part of a fire-separating element should be:
  - i. kept as few in number as possible; and
  - ii. kept as small as practicable; and
  - iii. fire-stopped (which in the case of a pipe or duct, should allow thermal movement).

**11.18** To prevent displacement, materials used for fire-stopping should be reinforced with (or supported by) materials of limited combustibility in the following circumstances:

- a. in all cases where the unsupported span is greater than 100mm; and
- b. in any other case where non-rigid materials are used (unless they have been shown to be satisfactory by test).

**11.19** Proprietary fire-stopping and sealing systems (including those designed for service penetrations) which have been shown by test to maintain the fire resistance of the wall or other element, are available and may be used.



## Section 11

Other fire-stopping materials include:

- cement mortar;
- gypsum-based plaster;
- cement-based or gypsum-based vermiculite/perlite mixes;
- glass fibre, crushed rock, blast furnace slag or ceramic-based products (with or without resin binders); and
- intumescent mastics.

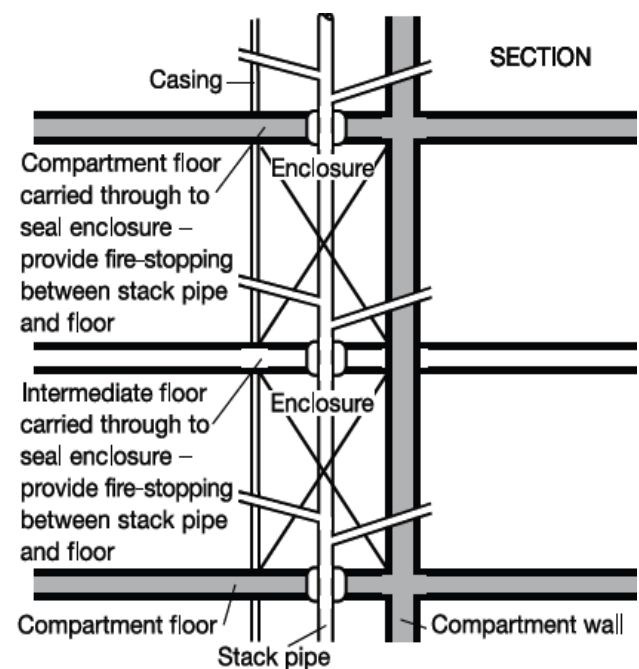
These may be used in situations appropriate to the particular material. Not all of them will be suitable in every situation.

Guidance on the process of design, installation and maintenance of passive fire protection is available in Ensuring best practice for passive fire protection in buildings (ISBN: 1 87040 919 1) produced by the Association for Specialist Fire Protection (ASFP).

Further information on the generic types of systems available, information about their suitability for different applications and guidance on test methods is given in the ASFP Red Book: *Fire Stopping and Penetration Seals for the Construction Industry – the ‘Red Book’* (ISBN:1 87040 923 X) published by the Association for Specialist Fire Protection and freely available from the ASFP website at [www.asfp.org.uk](http://www.asfp.org.uk).

### Diagram 38 Pipes penetrating structure

See para 6.24



#### Notes:

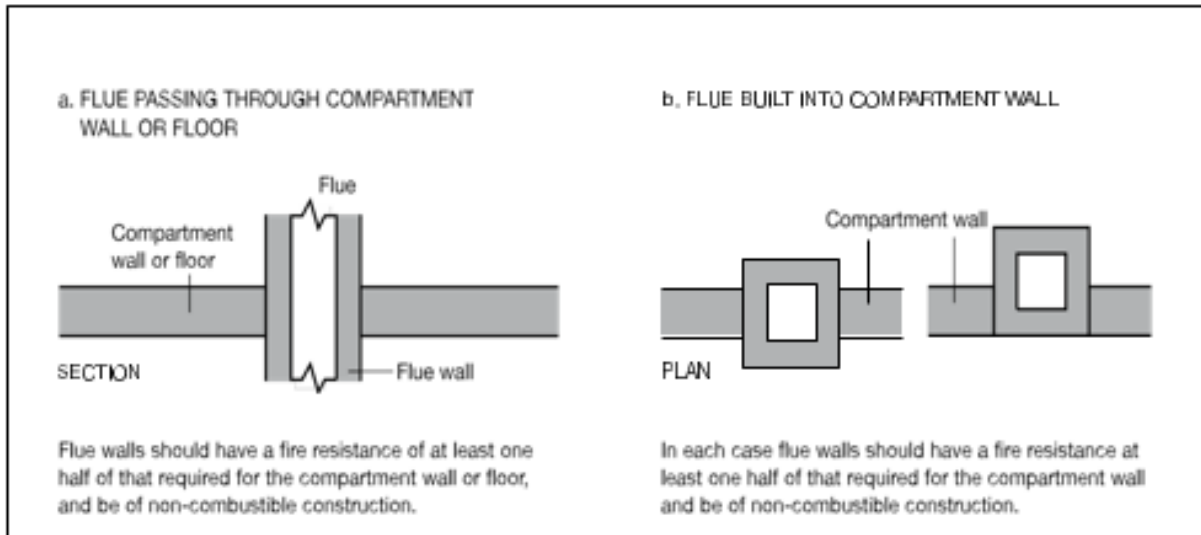
- The enclosure should:
  - be bounded by a compartment wall or floor, an outside wall, an intermediate floor, or a casing (see specification at 2 below);
  - have internal surfaces (except framing members) of Class 0 (National class) or Class B-s3, d2 or better (European class)
 

**Note:** When a classification includes 's3, d2', this means that there is no limit set for smoke production and/or flaming droplets/particles);
  - not have an access panel which opens into a circulation space or bedroom;
  - be used only for drainage, or water supply, or vent pipes for a drainage system.
- The casing should:
  - be imperforate except for an opening for a pipe or an access panel;
  - not be of sheet metal;
  - have (including any access panel) not less than 30 minutes fire resistance.
- The opening for a pipe, either in the structure or the casing, should be as small as possible and fire-stopped around the pipe.

Section 11

**Diagram 39 Flues penetrating compartment walls or floor (note that there is guidance in Approved Document J concerning hearths adjacent to compartment walls)**

See para 11.18



## Section 12

## B3

# Special provision for car parks and shopping complexes

### Introduction

**12.1** This section describes additional considerations which apply to the design and construction of car parks and shopping complexes.

### Car parks

#### General principles

**12.2** Buildings or parts of buildings used as parking for cars and other light vehicles are unlike other buildings in certain respects which merit some departures from the usual measures to restrict fire spread within buildings. Those are:

- a. The fire load is well defined; and
- b. Where the car park is well ventilated, there is a low probability of fire spread from one storey to another. Ventilation is the important factor and, as heat and smoke cannot be dissipated so readily from a car park that is not open-sided, fewer concessions are made. The guidance in paragraphs 12.3 to 12.6 is concerned with three ventilation methods: open-sided (high level of natural ventilation), natural ventilation and mechanical ventilation.

#### Open-sided car parks

**12.3** If the building, or separated part containing the car park, complies with the following provisions it may be regarded as an open-sided car park for the purposes of fire resistance assessment in Appendix A, Table A2. The provisions are that:

- a. there should not be any basement storeys;
- b. each storey should be naturally ventilated by permanent openings at each car parking level, having an aggregate vent area not less than 1/20th of the floor area at that level, of which at least half (1/40th) should be equally provided between two opposing walls;
- c. where one element of structure supports or carries or gives stability to another, the fire resistance of the supporting element should be no less than the minimum period of fire resistance for the other element (whether that other element is loadbearing or not).
- d. if the building is also used for any other purpose, the part forming the car park is a separated part and the fire resistance of any element of structure that supports or carries or gives stability to another element in the other part of the building should be no less than the minimum period of fire resistance for the elements it supports; and
- e. all materials used in the construction of the building, compartment or separated part should be non-combustible, except for:

## Section 12

- i. any surface finish applied to a floor or roof of the car park, or within any adjoining building, compartment or separated part to the structure enclosing the car park, if the finish meets all relevant aspects of the guidance on requirements B2 and B4;
- ii. any fire door;
- iii. any attendant's kiosk not exceeding 15m<sup>2</sup> in area; and
- iv. any shop mobility facility.

### Car parks which are not open-sided

**12.4** Where car parks do not have the standard of ventilation set out in paragraph 12.3(b), they are not regarded as open-sided and a different standard of fire resistance is necessary (the relevant provisions are given in Appendix A, Table A2).

Such car parks still require some ventilation, which may be by natural or mechanical means, as described in paragraphs 12.5 or 12.6 below.

### Natural ventilation

**12.5** Where car parks that are not open-sided are provided with some, more limited, natural ventilation, each storey should be ventilated by permanent openings (which can be at ceiling level) at each car parking level. These should have an aggregate free vent area not less than 1/40th of the floor area at that level, of which at least half should be split equally and provided between two opposing walls (1/160th on each side). (See Approved Document F Ventilation for additional guidance on normal ventilation of car parks.)

### Mechanical ventilation

**12.6** In most basement car parks and in enclosed car parks, it may not be possible to obtain the minimum standard of natural ventilation openings set out in paragraph 12.5. In such cases a system of mechanical ventilation should be provided as follows:

- a. the system should be independent of any other ventilating system (other than any system providing normal ventilation to the car park) and be designed to operate at 10 air changes per hour in a fire condition. (See Approved Document F Ventilation for guidance on normal ventilation of car parks);
- b. the system should be designed to run in two parts, each part capable of extracting 50% of the rates set out in (a) above and designed so that each part may operate singly or simultaneously;
- c. each part of the system should have an independent power supply which would operate in the event of failure of the main supply;
- d. extract points should be arranged so that 50% of the outlets are at high level and 50% at low level; and
- e. the fans should be rated to run at 300°C for a minimum of 60 minutes and the ductwork and fixings should be constructed of materials having a melting point not less than 800°C.

## Section 12

For further information on equipment for removing hot smoke, refer to BS EN 12101-3:2002.

An alternative method of providing smoke ventilation from enclosed car parks is given BS 7346-7:2006

### Shopping complexes

- 12.7** Whilst the provisions in this document about shops should generally be capable of application in cases where a shop is contained in a single separate building, the provisions may not be appropriate where a shop forms part of a complex. These may include covered malls providing access to a number of shops and common servicing areas. In particular, the provisions about maximum compartment size may be difficult to meet, bearing in mind that it would generally not be practical to compartment a shop from a mall serving it. To a lesser extent, the provisions about fire resistance, walls separating shop units, surfaces and boundary distances may pose problems.
- 12.8** To ensure a satisfactory standard of fire safety in shopping complexes, alternative measures and additional compensatory features to those set out in this document are appropriate. Such features are set out in Sections 6 and 7 of BS 5588-10:1991 and the relevant recommendations of those sections should be followed.

# External Fire Spread

# B4

## The Requirement

This Approved Document deals with the following Requirement from Part B of Schedule 1 to the Building Regulations 2010.

Requirement	Limits on application
<p><b>External fire spread</b></p> <p>B4.</p> <p>(1) The external walls of the building shall adequately resist the spread of fire over the walls and from one building to another, having regard to the height, use and position of the building.</p> <p>(2) The roof of the building shall adequately resist the spread of fire over the roof and from one building to another, having regard to the use and position of the building.</p>	
Regulation	
<p>Regulation 7 - Materials and workmanship</p> <p>7. (1) Building work shall be carried out—</p> <p>(a) with adequate and proper materials which—</p> <p>(i) are appropriate for the circumstances in which they are used,</p> <p>(ii) are adequately mixed or prepared, and</p> <p>(iii) are applied, used or fixed so as adequately to perform the functions for which they are designed; and</p> <p>(b) in a workmanlike manner.</p> <p>(2) Subject to paragraph (3), building work must be carried out so that materials which become part of an external wall, or specified attachment, of a relevant building are of a minimum European Classification A2-s1, d0 or A1, classified in accordance with BS EN 13501-1:2018 entitled “Fire classification of construction products and building elements. Classification using test data from reaction to</p>	

fire tests” (ISBN 978 0 580 95726 0) published by the British Standards Institution on 14<sup>th</sup> January 2019.

- (3) Paragraph (2) does not apply to—
- (a) cavity trays when used between two leaves of masonry;
  - (b) any part of a roof (other than any part of a roof which falls within paragraph (iv) of regulation 2(6)) if that part is connected to an external wall;
  - (c) door frames and doors;
  - (d) electrical installations;
  - (e) insulation and water proofing materials used below ground level;
  - (f) intumescent and fire stopping materials where the inclusion of the materials is necessary to meet the requirements of Part B of Schedule 1;
  - (g) membranes;
  - (h) seals, gaskets, fixings, sealants and backer rods;
  - (i) thermal break materials where the inclusion of the materials is necessary to meet the thermal bridging requirements of Part L of Schedule 1; or
  - (j) window frames and glass.
- (4) In this regulation—
- (a) a “relevant building” means a building with a storey (not including roof-top plant areas or any storey consisting exclusively of plant rooms) at least 18 metres above ground level and which—
    - (i) contains one or more dwellings;
    - (ii) contains an institution; or
    - (iii) contains a room for residential purposes (excluding any room in a hostel, hotel or boarding house);
  - (b) “above ground level” in relation to a storey means above ground level when measured from the lowest ground level adjoining the outside of a building to the top of the floor surface of the storey.

# Guidance

# B4

## Performance

In Welsh Ministers' view the Requirements of B4 will be met:

- a. if the external walls are constructed so that the risk of ignition from an external source and the spread of fire over their surfaces, is restricted, by making provision for them to have low rates of heat release;
- b. if the amount of unprotected area in the side of the building is restricted so as to limit the amount of thermal radiation that can pass through the wall, taking the distance between the wall and the boundary into account; and
- c. if the roof is constructed so that the risk of spread of flame and/or fire penetration from an external fire source is restricted.

In each case so as to limit the risk of a fire spreading from the building to a building beyond the boundary, or vice versa.

The extent to which this is necessary is dependent on the use of the building, its distance from the boundary and, in some cases, its height.

## Introduction

### External walls

**B4.i** The construction of external walls and the separation between buildings to prevent external fire spread are closely related.

The chances of fire spreading across an open space between buildings and the consequences if it does, depend on:

- a. the size and intensity of the fire in the building concerned;
- b. the distance between the buildings;
- c. the fire protection given by their facing sides; and
- d. the risk presented to people in the other building(s).

**B4.ii** Provisions are made in Section 13 for the fire resistance of external walls and to limit the susceptibility of the external surface of walls to ignition and to fire spread.

**B4.iii** Provisions are made in Section 14 to limit the extent of openings and other unprotected areas in external walls in order to reduce the risk of fire spread by radiation.

### Roofs

**B4.iv** Provisions are made in Section 15 for reducing the risk of fire spread between roofs and over the surfaces of roofs.



## Section 13

## B4

# Construction of external walls

### Introduction

**13.1** The external wall of a building should not provide a medium for fire spread if that is likely to be a risk to health and safety. Combustible materials and cavities in external walls can present such a risk, particularly in tall buildings. The guidance in this section is designed to reduce the risk of vertical fire spread in tall buildings and the risk of ignition from flames coming from adjacent buildings.

### Fire resistance standard

**13.2** This section does not deal with fire resistance for external walls. An external wall may need fire resistance to meet the requirements of Section 3 (Means of escape from flats), Section 6 (general provisions), Section 8 (loadbearing elements of structures) or Section 14 (space separation)

### Portal frames

**13.3** Portal frames are often used in single storey industrial and commercial buildings where there may be no need for fire resistance of the structure (Requirement B3). However, where a portal framed building is near a relevant boundary, the external wall near the boundary may need fire resistance to restrict the spread of fire between buildings.

It is generally accepted that a portal frame acts as a single structural element because of the moment-resisting connections used, especially at the column/rafter joints. Thus, in cases where the external wall of the building cannot be wholly unprotected, the rafter members of the frame, as well as the column members, may need to be fire protected.

Following an investigation of the behaviour of steel portal frames in fire, it is considered technically and economically feasible to design the foundation and its connection to the portal frame so that it would transmit the overturning moment caused by the collapse, in a fire, of unprotected rafters, purlins and some roof cladding, while allowing the external wall to continue to perform its structural function.

The design method for this is set out in the SCI publication *P313 Single storey steel framed buildings in fire boundary conditions*, 2002 (ISBN: 1 85942 135 0).

**Note 1:** The recommendations in the SCI publication for designing the foundation to resist overturning need not be followed if the building is fitted with a sprinkler system in accordance with paragraph 0.16.

**Note 2:** Normally, portal frames of reinforced concrete can support external walls requiring a similar degree of fire resistance without specific provision at the base to resist overturning.

## Section 13

**Note 3:** Existing buildings may have been designed to the following guidance which is also acceptable:

- a. the column members are fixed rigidly to a base of sufficient size and depth to resist overturning;
- b. there is brick, block or concrete protection to the columns up to a protected ring beam providing lateral support; and
- c. there is some form of roof venting to give early heat release. (The roof venting could be, for example, PVC rooflights covering some 10 per cent of the floor area and evenly spaced over the floor area.)

### Combustibility of external walls

**13.4** The external walls of buildings, other than those described in Regulation 7(4) of the Building Regulations, should either meet the guidance given in paragraphs 13.5 to 13.8 or meet the performance criteria given in the BRE Report *Fire performance of external thermal insulation for walls of multi-storey buildings* (BR 135) for external walls using full-scale test data from BS 8414-1:2015 or BS 8414-2:2015. The total amount of combustible material may also be limited in practice by the provisions for space separation in Section 14.

### External surfaces

**13.5** The external surfaces of walls should meet the provisions in Diagram 40, but where Regulation 7(2) applies (see 13.10 below), that regulation prevails over the provisions in the diagram.

### Insulation Materials/Products

**13.6** In a building with a storey 18m or more in height (see Diagram C6) any insulation product, filler material (not including gaskets, sealants and similar) etc. used in the construction of an external wall should be of limited combustibility or better (see Appendix A). This restriction does not apply to masonry cavity wall construction which complies with Diagram 34 in Section 10. Where Regulation 7(2) applies, that regulation prevails over all the provisions in this paragraph.

**Note 1:** Whilst the guidance above applies to any insulation product, filler material (not including gaskets, sealants and similar) etc. used in the construction of an external wall, consideration should be given to the choice of material used for any other parts of an external wall or attachments to the wall which could impact on the risk of fire spread over the wall.

**Note 2:** Best practice guidance for green walls (also called living walls) can be found in *Fire Performance of Green Roofs and Walls*, published by the Department for Communities and Local Government.

## Section 13

### Cavities and cavity barriers

**13.7** Cavity barriers should be provided in accordance with Section 10.

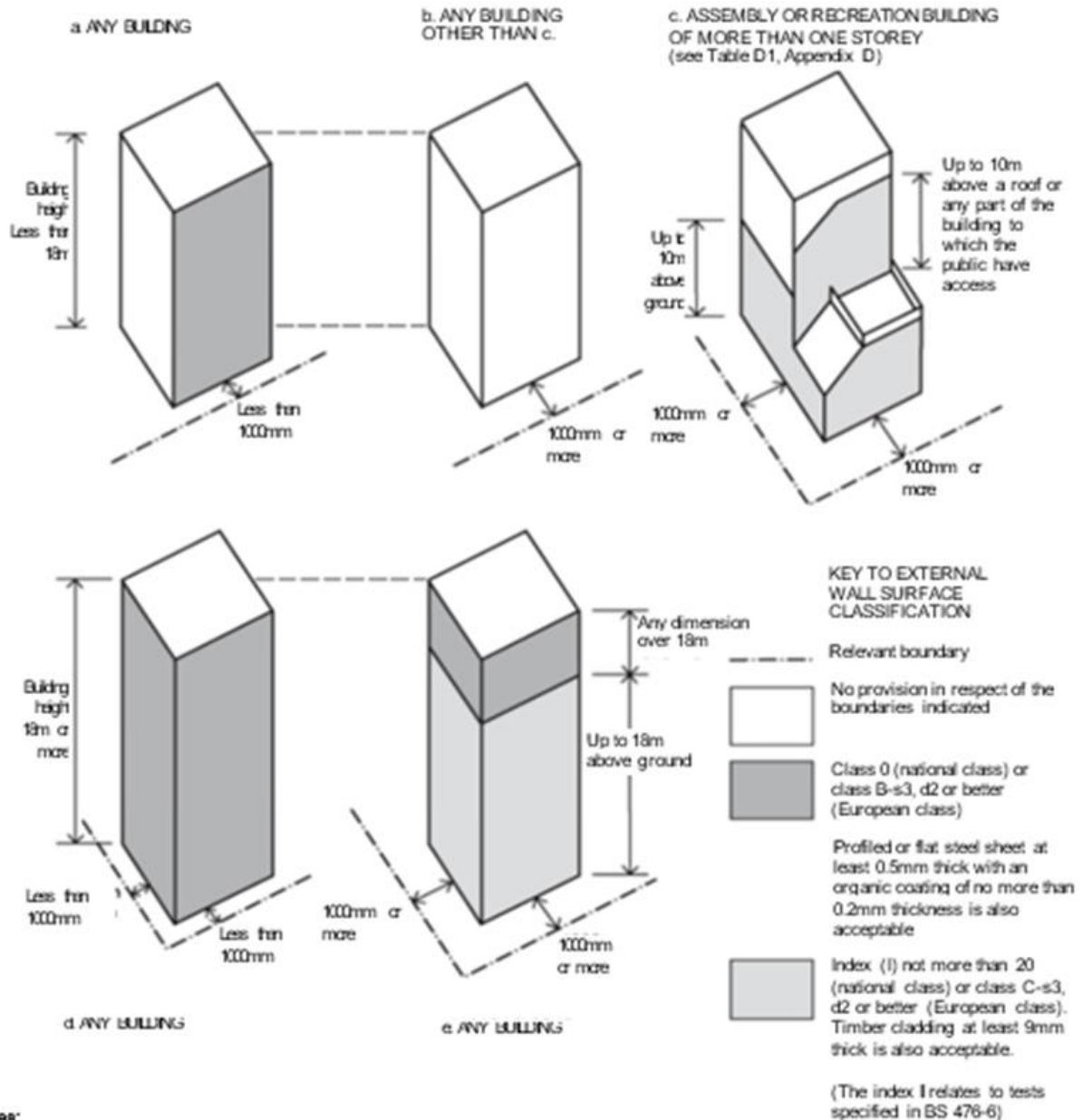
**13.8** In the case of an external wall construction, of a building which, by virtue of paragraph 9.10(d) (external cladding system with a masonry or concrete inner leaf), is not subject to the provisions of Table 13 *Maximum dimensions of cavities in non-domestic buildings*, the surfaces which face into cavities should also meet the provisions of Diagram 40, and provisions in Section 9, but where Regulation 7(2) applies, that regulation prevails over the guidance provided in Diagram 40 and Section 9.

Section 13

**Diagram 40 Provisions for external surfaces or walls**

**Note: Where Regulation 7(2) applies, it prevails over the provisions in this diagram**

See para 13.5 and 13.6



**Notes:**

- 1 The national classifications do not automatically equate with the equivalent European classifications, therefore, products cannot typically assume a European class unless they have been tested accordingly.
- 2 When a classification includes "s3, d2", this means that there is no limit set for smoke production and/or flaming droplets/particles.
- 3 Where a mixed-use building includes Assembly and Recreation Purpose Group(s) accommodation, the external surfaces of walls should meet the provisions in Diagram 40c.
- 4 Where Regulation 7(2) applies, it prevails over the provisions in this diagram.

## Section 13

### Regulation 7 – Materials and Workmanship Materials

**13.9** Regulation 7(1)(a) requires that materials used in building work are appropriate for the circumstances in which they are used. Regulation 7(2) sets requirements in respect of external walls and specified attachments in relevant buildings.

Note: Guidance on Regulation 7(1) can be found in Approved Document 7.

**13.10** Regulation 7(2) applies to any building with a storey at least 18m above ground level (as measured in accordance with Diagram C6) and which contains one or more dwellings; an institution; or a room for residential purposes (excluding any room in a hostel, hotel or a boarding house). It requires that all materials which become part of an external wall or specified attachment achieve European Class A2-s1, d0 or Class A1, other than those exempted by Regulation 7(3).

**Note 1:** The above includes student accommodation, care homes, sheltered housing, hospitals and dormitories in boarding schools.

**Note 2:** The requirement in Regulation 7(2) is limited to materials achieving European classification Class A2-s1, d0 or Class A1. Therefore materials achieving limited combustibility cannot be deemed to meet the requirement using an alternative classification method.

**13.11** External walls and specified attachments are defined in Regulation 2 and these definitions include any parts of the external wall as well as balconies and solar panels.

**13.12** Regulation 7(3) provides an exemption for certain components found in external walls and specified attachments.

#### Material change of use

**13.13** Regulations 5 and 6 provide that, where the use of a building is changed such that the building becomes a building described in Regulation 7(4), the construction of the external walls, and specified attachments, must be investigated and, where necessary, work must be carried out to ensure they only contain materials achieving European Class A2-s1, d0 or Class A1, other than those exempted by Regulation 7(3)

#### Further considerations

**13.14** The provisions of Regulation 7 apply in addition to the requirements of B4. Therefore, for buildings described in Regulation 7(4), the potential impact of any products incorporated into or onto the external walls should be carefully considered with regard to their number, size, orientation and position. Particular attention is drawn to the following points.

- a. Membranes used as part of the external wall construction should achieve a minimum classification of European Class B-s3, d0.
- b. Internal linings should comply with the guidance provided in Section 6.

## Section 13

- c. Any part of a roof should achieve the minimum performance as detailed in Section 14.
- d. As per Regulation 7(3), window frames and glass (including laminated glass) are exempted from Regulation 7(2). Window spandrel panels and infill panels must comply with Regulation 7(2).
- e. Thermal breaks are small elements used as part of the external wall construction to restrict thermal bridging. There is no minimum performance for these materials. However, they should not span two compartments and should be limited in size to the minimum required to restrict the thermal bridging (the principal insulation layer is not to be regarded as a thermal break).
- f. Regulation 7(2) only applies to specified attachments. Shop front signs and similar attachments are not covered by the requirements of Regulation 7(2), although attention is drawn to paragraph 13.14(g).
- g. Whilst Regulation 7(2) applies to materials which become part of an external wall or specified attachment, consideration should be given to other attachments to the wall which could impact on the risk of fire spread over the wall.

## Section 14

## B4

# Space separation

### Introduction

**14.1** The provisions in this Section are based on a number of assumptions and, whilst some of these may differ from the circumstances of a particular case, together they enable a reasonable standard of space separation to be specified. The provisions limit the extent of unprotected areas in the sides of a building (such as openings and areas with a combustible surface) which will not give adequate protection against the external spread of fire from one building to another.

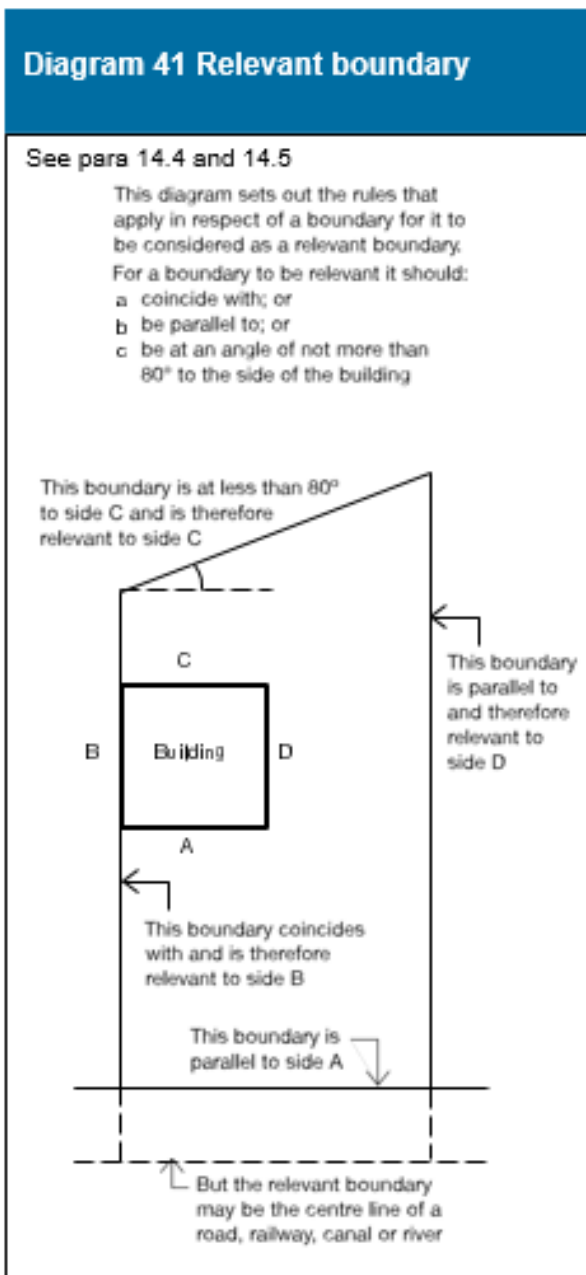
A roof is not subject to the provisions in this Section unless it is pitched at an angle greater than 70° to the horizontal (see definition for 'external wall' in Appendix E). Similarly, vertical parts of a pitched roof such as dormer windows (which taken in isolation might be regarded as a wall), would not need to meet the following provisions unless the slope of the roof exceeds 70°. It is a matter of judgement whether a continuous run of dormer windows occupying most of a steeply pitched roof should be treated as a wall rather than a roof.

**14.2** The assumptions are:

- a. that the size of a fire will depend on the compartmentation of the building, so that a fire may involve a complete compartment, but will not spread to other compartments;
- b. that the intensity of the fire is related to the use of the building (i.e. purpose group), but that it can be moderated by an automatic fire suppression system;
- c. that Residential and Assembly and Recreation Purpose Groups represent a greater life risk than other uses;
- d. that there is a building on the far side of the boundary that has a similar elevation to the one in question and that it is at the same distance from the common boundary; and
- e. that the amount of radiation that passes through any part of the external wall that has fire resistance may be discounted.

**14.3** Where a reduced separation distance is desired (or an increased amount of unprotected area) it may be advantageous to construct compartments of a smaller size.

## Section 14



## Boundaries

**14.4** The use of the distance to a boundary, rather than to another building, in measuring the separation distance, makes it possible to calculate the allowable proportion of unprotected areas, regardless of whether there is a building on an adjoining site and regardless of the site of that building or the extent of any unprotected areas that it might have.

A wall is treated as facing a boundary if it makes an angle with it of  $80^\circ$  or less (see Diagram 41).



## Section 14

Usually only the distance to the actual boundary of the site needs to be considered. But in some circumstances, when the site boundary adjoins a space where further development is unlikely, such as a road, then part of the adjoining space may be included as falling within the relevant boundary for the purposes of this Section. The meaning of the term boundary is explained in Diagram 41.

### Relevant boundaries

**14.5** The boundary which a wall faces, whether it is the actual boundary of the site or a notional boundary, is called the relevant boundary (see Diagrams 41 and 42).

### Notional boundaries

**14.6** Generally separation distance between buildings on the same site is discounted. In some circumstances the distances to other buildings on the same site need to be considered. This is done by assuming that there is a boundary between those buildings. This assumed boundary is called a notional boundary.

A notional boundary is assumed to exist where:

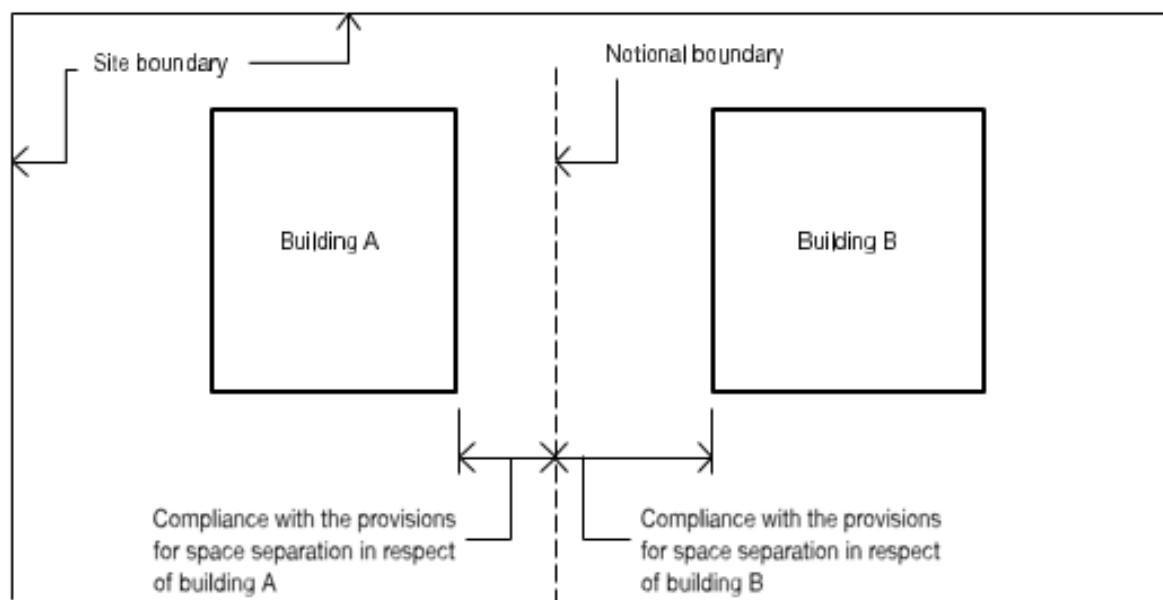
- a. either or both of the buildings concerned are in the Residential or Assembly and Recreation Purpose Groups; or
- b. more than one building is constructed on the same site but is to be operated/managed by different organisations.

## Section 14

The appropriate rules are given in Diagram 42.

### Diagram 42 Notional boundary

See para 14.6



The notional boundary should be set in the area between the two buildings using the following rules:

1. The notional boundary is assumed to exist in the space between the buildings and is positioned so that one of the buildings would comply with the provisions for space separation having regard to the amount of its unprotected area. In practice, if one of the buildings is existing, the position of the boundary will be set by the space separation factors for that building.
2. The siting of the new building, or the second building if both are new, can then be checked to see that it also complies, using the notional boundary as the relevant boundary for the second building.

## Section 14

### Unprotected areas and fire resistance

**14.7** Any part of an external wall which has less fire resistance than the appropriate amount given in Appendix A, Table A2, is considered to be an unprotected area.

### External walls of protected shafts forming stairways

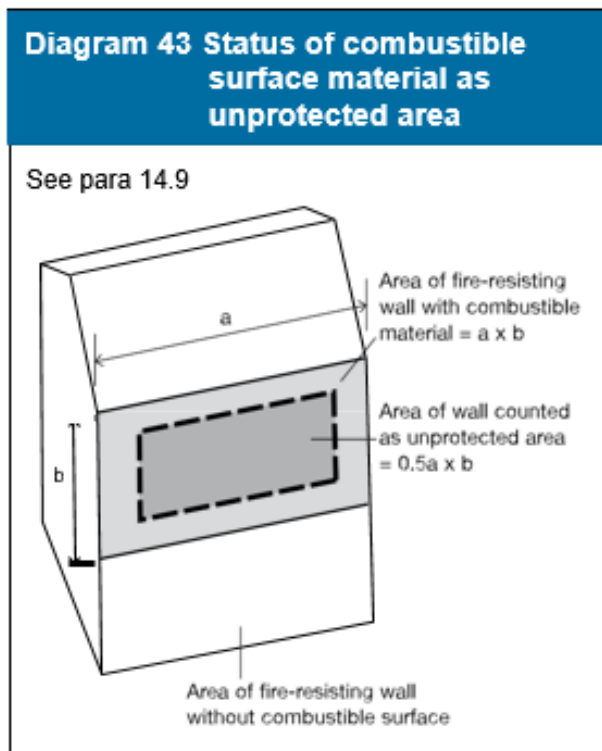
**14.8** Any part of an external wall of a stairway in a protected shaft is excluded from the assessment of unprotected area.

**Note:** There are provisions in the guidance to B1 (Diagram 24) and B5 (paragraph 18.11) which refers to Section 3 of BS 5588-5:2004 about the relationship of external walls for protected stairways to the unprotected areas of other parts of the building.

### Status of combustible surface materials as unprotected area

**14.9** If an external wall has the appropriate fire resistance, but has combustible material more than 1mm thick as its external surface, then that wall is counted as an unprotected area amounting to half the actual area of the combustible material, see Diagram 43. (For the purposes of this provision, a material with a Class 0 rating (National class) or Class B-s3, d2 rating (European class) (see Appendix A, paragraphs 7 and 13) need not be counted as unprotected area).

**Note:** When a classification includes “s3, d2”, this means that there is no limit set for smoke production and/or flaming droplets/particles.



## Section 14

### Small unprotected areas

**14.10** Small unprotected areas in an otherwise protected area of wall are considered to pose a negligible risk of fire spread and may be disregarded. Diagram 44 shows the constraints that apply to the placing of such areas in relation to each other and to lines of compartmentation inside the building. These constraints vary according to the size of each unprotected area.

### Canopies

**14.11** Some canopy structures would be exempt from the application of the Building Regulations by falling within Class 6 or Class 7 of Schedule 2 to the Regulations (Exempt Buildings and Works). Many others may not meet the exemption criteria and in such cases the provisions in this Section about limits of unprotected areas could be onerous.

In the case of a canopy attached to the side of a building, provided that the edges of the canopy are at least 2m from the relevant boundary, separation distance may be determined from the wall rather than the edge of the canopy (see Diagram 45).

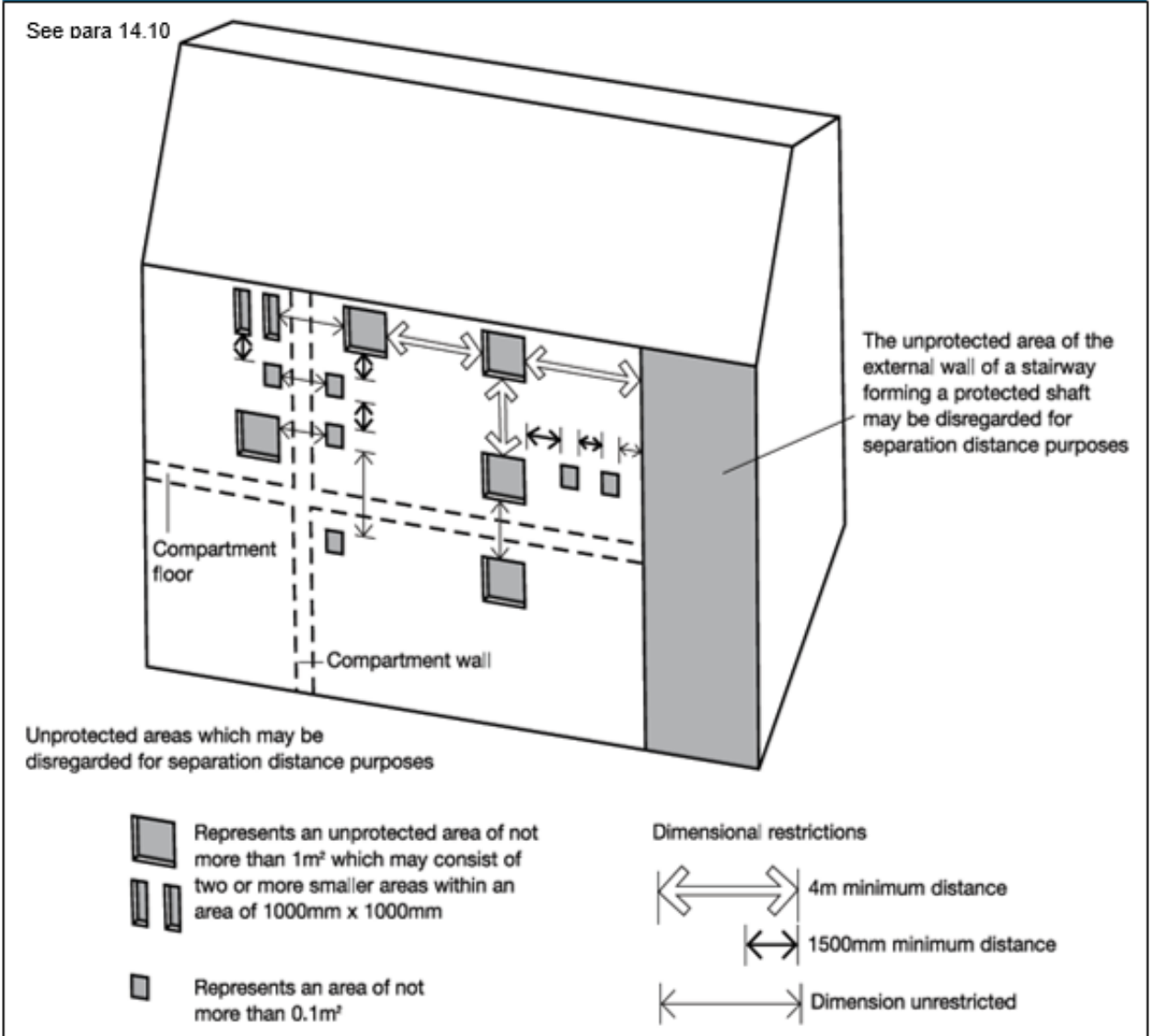
In the case of a free-standing canopy structure above a limited risk or controlled hazard (for example over petrol pumps), in view of the high degree of ventilation and heat dissipation achieved by the open sided construction and provided the canopy is 1000mm or more from the relevant boundary, the provisions for space separation could reasonably be disregarded.

### Large uncompartmented buildings

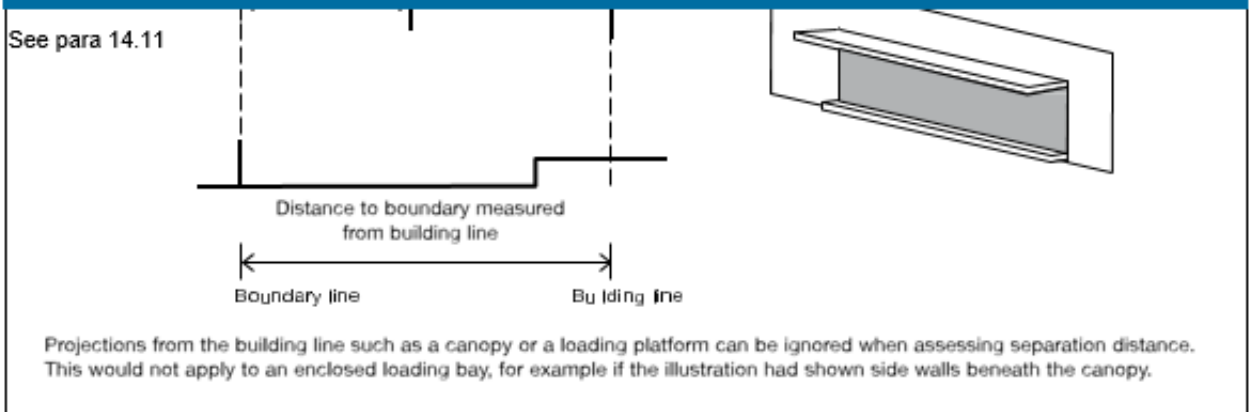
**14.12** Parts of the external wall of an uncompartmented building which are more than 30m above mean ground level, may be disregarded in the assessment of unprotected area.

Section 14

**Diagram 44 Unprotected areas which may be disregarded in assessing the separation distance from the boundary**



**Diagram 45 The effect of a canopy on separation distance**



## Section 14

### External walls within 1000mm of the relevant boundary

**14.13** A wall situated within 1000mm from any point on the relevant boundary and including a wall coincident with the boundary, will meet the provisions for space separation if:

- a. the only unprotected areas are those shown in Diagram 44 or referred to in paragraph 14.12; and
- b. the rest of the wall is fire-resisting from both sides.

### External walls 1000mm or more from the relevant boundary

**14.14** A wall situated at least 1000mm from any point on the relevant boundary will meet the provisions for space separation if:

- a. the extent of unprotected area does not exceed that given by one of the methods referred to in paragraph 14.15; and
- b. the rest of the wall (if any) is fire-resisting from the inside of the building.

### Methods for calculating acceptable unprotected area

**14.15** Two simple methods are given in this Approved Document for calculating the acceptable amount of unprotected area in an external wall that is at least 1000mm from any point on the relevant boundary. (For walls within 1000mm of the boundary see 14.13 above.)

**Method 1** may be used for small residential buildings which do not belong to Purpose Group m2a (Institutional type premises) and is set out in paragraph 14.19.

**Method 2** may be used for most buildings or compartments for which Method 1 is not appropriate and is set out in paragraph 14.20.

There are other more precise methods, described in a BRE report External fire spread: Building separation and boundary distances (BR 187, BRE 1991), which may be used instead of Methods 1 and 2. The “Enclosing Rectangle” and “Aggregate Notional Area” methods are included in the BRE report.

### Basis for calculating acceptable unprotected area

**14.16** The basis of Methods 1 and 2 is set out in Fire Research Technical Paper No 5, 1963. This has been reprinted as part of the BRE report referred to in paragraph 14.15. The aim is to ensure that the building is separated from the boundary by at least half the distance at which the total thermal radiation intensity received from all unprotected areas in the wall would be 12.6 kw/m<sup>2</sup> (in still air), assuming the radiation intensity at each unprotected area is:

- a. 84 kw/m<sup>2</sup>, if the building is in the Residential, Office or Assembly and Recreation Purpose Groups, or is an open-sided multi-storey car park in Purpose Group 7(b); and
- b. 168 kw/m<sup>2</sup>, if the building is in the Shop and Commercial, Industrial, Storage or Other non-residential Purpose Groups.

## Section 14

### Automatic fire suppression systems

**14.17** If a building is fitted throughout with an automatic fire suppression system, it is reasonable to assume that the intensity and extent of a fire will be reduced. The automatic fire suppression system should be in accordance with Section 2. In these circumstances the boundary distance may be half that for an otherwise similar, but un-suppressed, building, subject to there being a minimum distance of 1m. Alternatively, the amount of unprotected area may be doubled if the boundary distance is maintained.

**Note:** The presence of an automatic fire suppression system may be taken into account in a similar way when using the BRE report referred to in paragraph 14.15.

### Atrium buildings

**14.18** If a building contains one or more atria, the recommendations of clause 28.2 in BS 5588-7:1997 should be followed.

### Method 1

**14.19** This method applies only to a building intended to be used for block of flats or other residential purposes (not Institutional), which is 1000mm or more from any point on the relevant boundary.

The following rules for determining the maximum unprotected area should be read with Diagram 46.

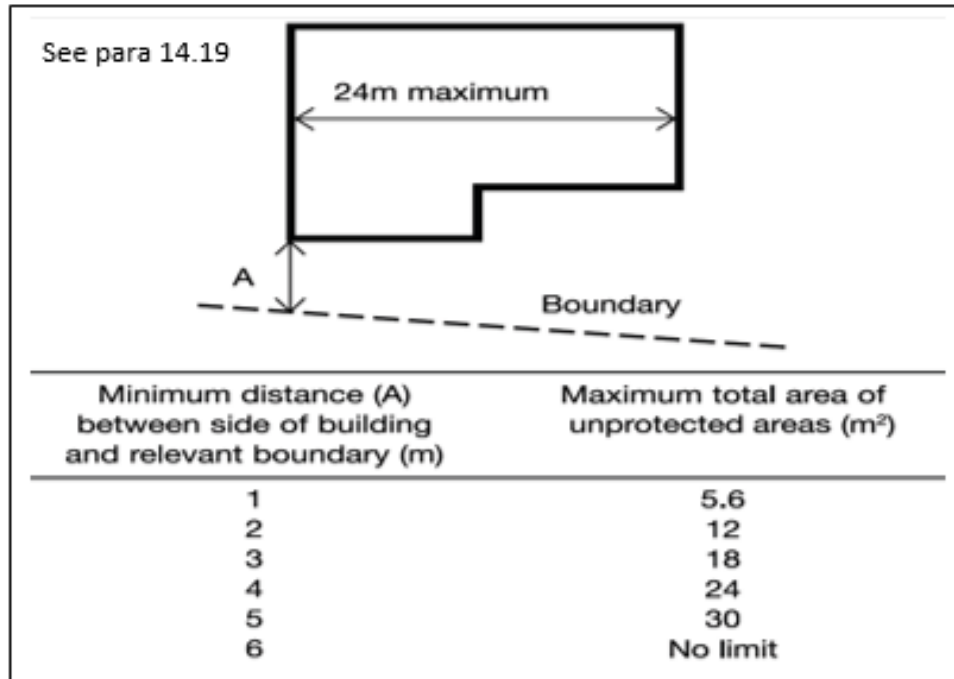
- a. The building should not exceed 3 storeys in height (basements not counted) or be more than 24m in length:
- b. Each side of the building will meet the provisions for space separation if:
  - i. the distance of the side of the building from the relevant boundary; and
  - ii. the extent of the unprotected area, are within the limits given in Diagram 46.

**Note:** In calculating the maximum unprotected area, any areas falling within the limits shown in Diagram 44 and referred to in paragraph 14.10, can be disregarded.

- c. Any parts of the side of the building in excess of the maximum unprotected area should be fire-resisting.

Section 14

**Diagram 46 Permitted unprotected areas in small residential buildings**





Section 14

**Method 2**

**14.20** This method applies to a building or compartment intended for any use and which is not less than 1000mm from any point on the relevant boundary.

The following rules for determining the maximum unprotected area should be read with Table 15.

- a. The building or compartment should not exceed 10m in height except for an open-sided car park in Purpose Group 7(b) (see paragraph 12.3).

**Note:** For any building or compartment more than 10m in height, the methods set out in the BRE report External fire spread: Building separation and boundary distances can be applied.

- b. Each side of the building will meet the provisions for space separation if either:
  - i. the distance of the side of the building from the relevant boundary; and
  - ii. the extent of unprotected area, are within the appropriate limits given in Table 15.

**Note:** In calculating the maximum unprotected area, any areas shown in Diagram 44 and referred to in paragraph 14.10, can be disregarded.

- c. any parts of the side of the building in excess of the maximum unprotected area should be fire-resisting.

Table 15 Permitted unprotected areas in small buildings or compartments		
Minimum distance between side of building and relevant boundary (m)	Maximum total percentage of unprotected area %	
Purpose groups		
Residential, office, assembly and recreation	Shop and commercial industrial, storage and other non-residential	
(1)	(2)	(3)
n.a	1	4
1	2	8
2.5	5	20
5	10	40
7.5	15	60
10	20	80
12.5	25	100

**Notes:**

n.a. = not applicable

- a. Intermediate values may be obtained by interpolation.
- b. For buildings which are fitted throughout with an automatic fire suppression system, see para 14.17.
- c. In the case of open-sided car parks in Purpose Group 7(b), the distances set out in column (1) may be used instead of those in column (2).
- d. The total percentage of unprotected area is found by dividing the total unprotected area by the area of a rectangle that encloses all the unprotected areas and multiplying the result by 100.

## Section 15

## B4

# Roof coverings

### Introduction

- 15.1** The provisions in this section limit the use, near a boundary, of roof coverings which will not give adequate protection against the spread of fire over them. The term roof covering is used to describe constructions which may consist of one or more layers of material, but does not refer to the roof structure as a whole. The provisions in this Section are principally concerned with the performance of roofs when exposed to fire from the outside.
- 15.2** The circumstances when a roof is subject to the provisions in Section 14 for space separation are explained in paragraph 14.1.

### Other controls on roofs

- 15.3** There are provisions concerning the fire properties of roofs in three other Sections of this document. In the guidance to B1 (paragraph 6.3) there are provisions for roofs that are part of a means of escape. In the guidance to B2 (paragraph 7.12) there are provisions for the internal surfaces of rooflights as part of the internal lining of a room or circulation space. In the guidance to B3 there are provisions in Section 8 for roofs which are used as a floor and in Section 9 for roofs that pass over the top of a compartment wall.

### Classification of performance

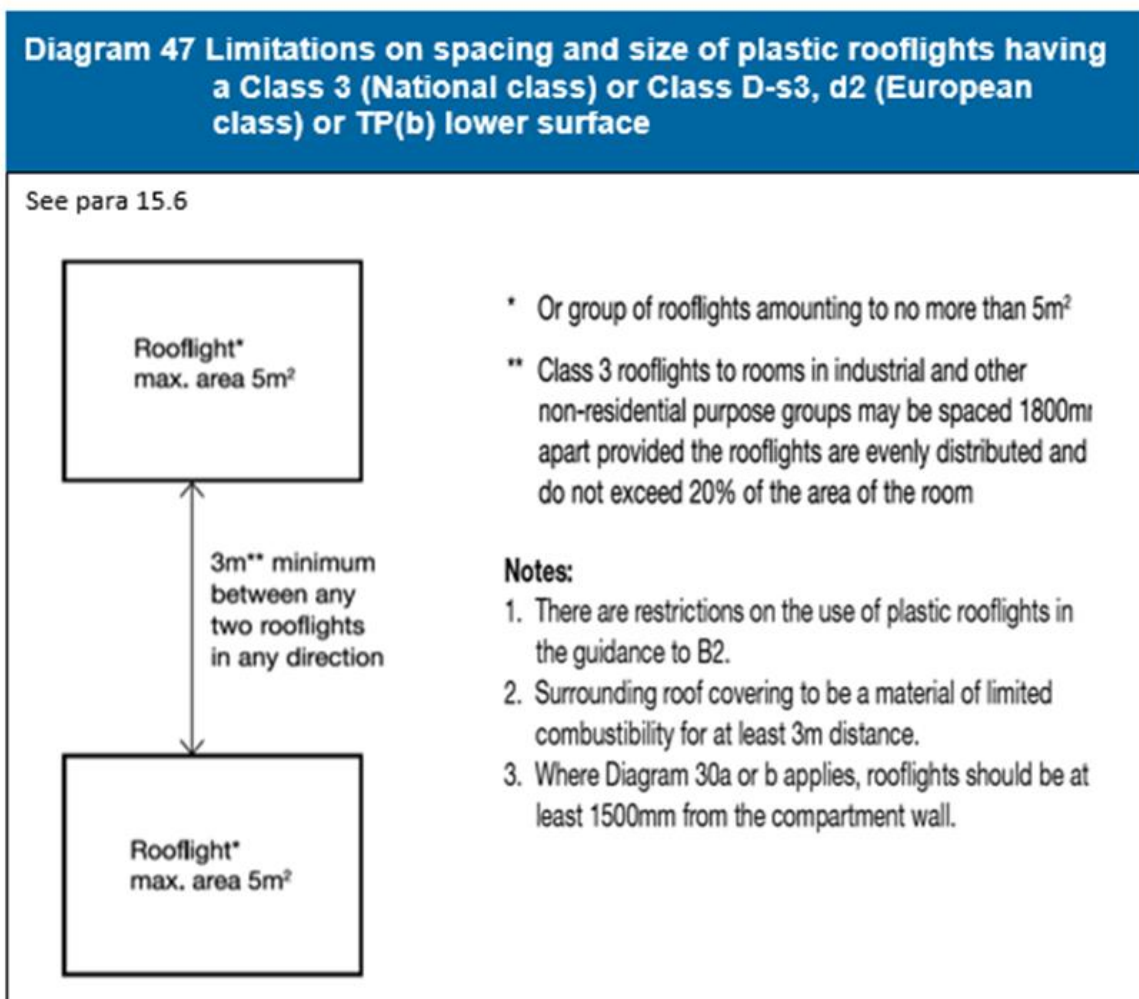
- 15.4** The performance of roof coverings is designated by reference to the test methods specified in BS 476-3: 2004 or determined in accordance with BS EN 13501-5:2005, as described in Appendix A. The notional performance of some common roof coverings is given in Table A5 of Appendix A. Rooflights are controlled on a similar basis and plastic rooflights described in paragraph 15.6 and 15.7 may also be used.

### Separation distances

- 15.5** The separation distance is the minimum distance from the roof (or part of the roof) to the relevant boundary, which may be a notional boundary.

Table 16 sets out separation distances according to the type of roof covering and the size and use of the building. There are no restrictions on the use of roof coverings designated AA, AB or AC (National class) or BROOF(t4) (European class) classification. In addition, roof covering products (and/or materials) as defined in Commission Decision 2000/553/EC of 6th September 2000 implementing Council Directive 89/106/EEC as regards the external fire performance of roof coverings can be considered to fulfil all of the requirements for performance characteristic “external fire performance” without the need for testing **provided that any national provisions on the design and execution of works are fulfilled**. That is, the roof covering products (and/ or materials) defined in this Commission Decision can be used without restriction.

## Section 15



### Plastic rooflights

**15.6** Table 17 sets out the limitations on the use of plastic rooflights which have at least a Class 3 (National class) or Class D-s3, d2 (European class) lower surface and Table 18 sets out the limitations on the use of thermoplastic materials with a TP(a) rigid or TP(b) classification (see also Diagram 47). The method of classifying thermoplastic materials is given in Appendix A.

**15.7** When used in rooflights, a rigid thermoplastic sheet product made from polycarbonate or from unplasticised PVC, which achieves a Class 1 (National class) rating for surface spread of flame when tested to BS 476-7:1971 (or 1987 or 1997) Surface spread of flame tests for materials, or Class C-s3, d2 (European class) can be regarded as having an AA (National class) designation or BROOF(t4) (European class) classification, other than for the purposes of Diagram 30.

### Unwired glass in rooflights

**15.8** When used in rooflights, unwired glass at least 4mm thick can be regarded as having an AA designation (National class) designation or BROOF(t4) (European class) classification.

Section 15

## Thatch and wood shingles

**15.9** Thatch and wood shingles should be regarded as having an AD/BD/CD designation or E<sub>ROOF</sub>(t4) (European class) classification in Table 16 if performance under BS 476-3: 1958 2004 or BS EN 13501-5 respectively cannot be established.

Table 16 Limitations on roof coverings*					
Designation† of covering of roof or part of roof		Minimum distance from any point on relevant boundary			
National Class	European Class	Less than 6m	At least 6m	At least 12m	At least 20m
AA, AB or AC	B <sub>ROOF</sub> (t4)	●	●	●	●
BA, BB or BC	C <sub>ROOF</sub> (t4)	○	●	●	●
CA, CB or CC	D <sub>ROOF</sub> (t4)	○	● (1) (2)	● (1)	●
AD, BD or CD	E <sub>ROOF</sub> (t4)	○	● (1) (2)	● (1)	● (1)
DA, DB, DC or DD	F <sub>ROOF</sub> (t4)	○	○	○	● (1) (2)

**Notes:**

\* See paragraph 15.8 for limitations on glass; paragraph 15.9 for limitations on thatch and wood shingles; and paragraphs 15.6 and 15.7 and Tables 6 and 7 for limitations on plastic rooflights.

† The designation of external roof surfaces is explained in Appendix A. (See Table A5 for notional designations of roof coverings.)

Separation distances do not apply to the boundary between roofs of a pair of semi-detached houses (see para 15.5) and to enclosed/ covered walkways. However, see Diagram 30 if the roof passes over the top of a compartment wall. Polycarbonate and PVC rooflights which achieve a Class 1 rating by test, see paragraph 16.7, may be regarded as having an AA designation.

Openable polycarbonate and PVC rooflights which achieve a Class 1 (National class) or Class C-s3, d2 (European class) rating by test, see paragraph 11.7, may be regarded as having an AA (National class) designation or B<sub>ROOF</sub>(t4) (European class) classification.

● Acceptable.

○ Not acceptable.

1. Not acceptable on any of the following buildings:

- a. Houses in terraces of three or more houses.
- b. Any other buildings with a cubic capacity of more than 1500m<sup>3</sup>.

2. Acceptable on buildings not listed in Note 1, provided that part of the roof is no more than 3m<sup>2</sup> in area and is at least 1500mm from any similar part, with the roof between the parts covered with a material of limited combustibility.

Section 15

<b>Table 17 Class 3 (National class) or D-s3, d2 (European class) plastic rooflights: limitations on use and boundary distance</b>			
<b>Minimum classification on lower surface <sup>(1)</sup></b>	<b>Space which rooflight can serve</b>	<b>Minimum distance from any point on relevant boundary to rooflight with an external designation† of:</b>	
		<b>AD BD CD (National class) E<sub>ROOF</sub>(t4) (European class) CA CB CC or D<sub>ROOF</sub>(t4) (European class)</b>	<b>DA DB DC DD or (National class), or F<sub>ROOF</sub>(t4) (European class)</b>
Class 3	a. Balcony, verandah, carport, covered way or loading bay, which has at least one longer side wholly or permanently open b. Detached swimming pool c. Conservatory, garage or outbuilding, with a maximum floor area of 40m <sup>2</sup>	6m	20m
	d. Circulation space <sup>(2)</sup> (except a protected stairway) e. Room <sup>(2)</sup>	6m <sup>(3)</sup>	20m <sup>(3)</sup>

**Notes:**

† The designation of external roof surfaces is explained in Appendix A.

None of the above designations are suitable for protected stairways – see paragraph 7.12.

Polycarbonate and PVC rooflights which achieve a Class 1 (National class) or Class C-s3, d2 (European class) rating by test, see paragraph 15.7, may be regarded as having an AA designation or BROOF(t4) (European class) classification.

Where Diagram 30a or b applies, rooflights should be at least 1.5m from the compartment wall.

Products may have upper and lower surfaces with different properties if they have double skins or are laminates of different materials; in which case the more onerous distance applies.

1. See also the guidance to B2.
2. Single skin rooflight only, in the case of non-thermoplastic material.
3. The rooflight should also meet the provisions of Diagram 47.

Section 15

<b>Table 18 TP(a) and TP(b) plastic rooflights: limitations on use and boundary distance</b>			
<b>Minimum classification on lower surface <sup>(1)</sup></b>	<b>Space which rooflight can serve</b>	<b>Minimum distance from any point on relevant boundary to rooflight with an external surface classification <sup>(1)</sup> of:</b>	
		<b>TP(a)</b>	<b>TP(b)</b>
1. TP(a) rigid	Any space except a protected stairway	6m <sup>(2)</sup>	Not applicable
2. TP(b)	a. Balcony, verandah, carport, covered way or loading bay, which has at least one longer side wholly or permanently open b. Detached swimming pool c. Conservatory, garage or outbuilding, with a maximum floor area of 40m <sup>2</sup>	Not applicable	6m
	d. Circulation space <sup>(3)</sup> (except a protected stairway) e. Room <sup>(3)</sup>	Not applicable	6m <sup>(4)</sup>

**Notes:**

None of the above designations are suitable for protected stairways – see paragraph 7.12.

Polycarbonate and PVC rooflights which achieve a Class rating by test, see paragraph 15.7, may be regarded as having an AA designation.

Where Diagram 30a or b applies, rooflights should be at least 1.5m from the compartment wall.

Products may have upper and lower surfaces with different properties if they have double skins or are laminates of different materials; in which case the more onerous distance applies.

1. See also the guidance to B2.
2. No limit in the case of any space described in 2a, b & c.
3. Single skin rooflight only, in the case of non-thermoplastic material.
4. The rooflight should also meet the provisions of Diagram 47.

# Access and facilities for the Fire and Rescue Service

## B5

### The Requirement

This Approved Document deals with the following Requirement from Part B of Schedule 1 to the Building Regulations 2010.

Requirement	Limits on application
<p><b>Access and facilities for the fire service</b></p> <p>B5.(1) The building shall be designed and constructed so as to provide reasonable facilities to assist firefighters in the protection of life.</p> <p>(2) Reasonable provision shall be made within the site of the building to enable fire appliances to gain access to the building.</p>	

# Guidance

# B5

---

## Performance

In Welsh Ministers' view the Requirements of B5 will be met:

- a. if there is sufficient means of external access to enable fire appliances to be brought near to the building for effective use;
- b. if there is sufficient means of access into and within, the building for firefighting personnel to effect search and rescue and fight fire;
- c. if the building is provided with sufficient internal fire mains and other facilities to assist firefighters in their tasks; and
- d. if the building is provided with adequate means for venting heat and smoke from a fire in a basement.

These access arrangements and facilities are only required in the interests of the health and safety of people in and around the building. The extent to which they are required will depend on the use and size of the building in so far as it affects the health and safety of those people.

## Introduction

**B5.i** The guidance given here covers the selection and design of facilities for the purpose of protecting life by assisting the fire and rescue service. To assist the fire and rescue service some or all of the following facilities may be necessary, depending mainly on the size of the building:

- a. vehicle access for fire appliances;
- b. access for firefighting personnel;
- c. the provision of fire mains within the building;
- d. venting for heat and smoke from basement areas;
- e. the provision of adequate water supplies.

If it is proposed to deviate from the general guidance in sections 16 to 19 then it would be advisable to seek advice from the relevant Fire and Rescue Service at the earliest opportunity, even where there is no statutory duty to consult.

## Facilities appropriate to a specific building

**B5.ii** The main factor determining the facilities needed to assist the fire and rescue service is the size of the building. Generally speaking firefighting is carried out within the building.

- a. In deep basements and tall buildings (see paragraph 18.2) firefighters will invariably work inside. They need special access facilities (see Section 18), equipped with fire mains (see Section 16). Fire appliances will need access to entry points near the fire mains (see Section 17).



## Section 15

- b. In other buildings, the combination of personnel access facilities offered by the normal means of escape and the ability to work from ladders and appliances on the perimeter, will generally be adequate without special internal arrangements. Vehicle access may be needed to some or all of the perimeter, depending on the size of the building (see Section 16).

**Note:** Where an alternative approach outside the scope of this Approved Document has been used to justify the means of escape it may be necessary to consider additional provisions for firefighting access.

- c. For small buildings, it is usually only necessary to ensure that the building is sufficiently close to a point accessible to fire and rescue service vehicles (see paragraph 17.2).
- d. In taller blocks of flats, fire and rescue service personnel access facilities are needed within the building, although the high degree of compartmentation means that some simplification is possible compared to other tall buildings (see paragraph 18.12);
- e. Products of combustion from basement fires tend to escape via stairways, making access difficult for fire and rescue service personnel. The problem can be reduced by providing vents (see Section 18). Venting can improve visibility and reduce temperatures, making search, rescue and firefighting less difficult.

### Insulating core panels

**B5.iii** Guidance on the fire behaviour of insulating core panels used for internal structures is given in Appendix F.

## Section 16

## B5

# Fire mains and hydrants

### Introduction

**16.1** Fire mains are installed in a building and equipped with valves etc so that the fire and rescue service may connect hoses for water to fight fires inside the building.

Fire mains may be of the 'dry' type which are normally empty and are supplied through hose from a fire and rescue service pumping appliance. Alternatively, they may be of the 'wet' type where they are kept full of water and supplied from tanks and pumps in the building. There should be a facility to allow a wet system to be replenished from a pumping appliance in an emergency.

### Provision of fire mains

**16.2** Buildings with firefighting shafts should be provided with fire mains in those shafts and, where necessary, in protected escape stairs. The criteria for the provision of firefighting shafts and fire mains in such buildings are given in Section 18.

**16.3** Fire mains may also be provided in other buildings where vehicle access is not provided in accordance with Table 19 (see paragraphs 17.6 & 17.7) or paragraphs 17.2 or 17.3.

### Number and location of fire mains

**16.4** In buildings provided with fire mains for the purposes of paragraph 16.3, outlets from fire mains should be located to meet the hose criterion set out in paragraph 18.8. This does not imply that these stairs need to be designed as firefighting shafts.

### Design and construction of fire mains

**16.5** The outlets from fire mains should be located within the protected enclosure of a stairway or a protected lobby where one is provided (see Diagram 52).

**16.6** Guidance on other aspects of the design and construction of fire mains, not included in the provisions of this Approved Document, should be obtained from BS 9990:2006.

**Note:** Wet fire mains should be provided in buildings with a floor at more than 50m above fire and rescue service vehicle access level. In lower buildings where fire mains are provided, either wet or dry mains are suitable.

### Provision of private hydrants

**16.7** Where a building, which has a compartment of 280m<sup>2</sup> or more in area, is being erected more than 100m from an existing fire-hydrant additional hydrants should be provided as follows;

## Section 16

- a. **Buildings provided with fire mains** – hydrants should be provided within 90m of dry fire main inlets.
- b. **Buildings not provided with fire mains** – hydrants should be provided within 90m of an entry point to the building and not more than 90m apart.

Each fire hydrant should be clearly indicated by a plate, affixed nearby in a conspicuous position, in accordance with BS 3251:1976.

**16.8** Where no piped water supply is available, or there is insufficient pressure and flow in the water main, or an alternative arrangement is proposed, the alternative source of supply should be provided in accordance with the following recommendations:

- a. a charged static water tank of at least 45,000 litre capacity; or
- b. a spring, river, canal or pond capable of providing or storing at least 45,000 litres of water at all times of the year, to which access, space and a hard standing are available for a pumping appliance; or
- c. any other means of providing a water supply for firefighting operations considered appropriate by the fire and rescue authority.

## Section 17

## B5

# Vehicle access

### Introduction

**17.1** For the purposes of this Approved Document vehicle access to the exterior of a building is needed to enable high reach appliances, such as turntable ladders and hydraulic platforms, to be used and to enable pumping appliances to supply water and equipment for firefighting, search and rescue activities. Access requirements increase with building size and height. Fire mains (see Section 16) enable firefighters within the building to connect their hoses to a water supply. In buildings fitted with fire mains, pumping appliances need access to the perimeter at points near the mains, where firefighters can enter the building and where in the case of dry mains, a hose connection will be made from the appliance to pump water into the main.

The vehicle access requirements described in Table 19 for buildings without fire mains, do not apply to blocks of flats, because access is required to each individual dwelling (see paragraph 17.3), or to buildings with fire mains.

Vehicle access routes and hard-standings should meet the criteria described in paragraphs 17.7 to 17.10 where they are to be used by fire and rescue service vehicles.

**Note:** Requirements cannot be made under the Building Regulations for work to be done outside the site of the works shown on the deposited plans, building notice or initial notice.

In this connection it may not always be reasonable to upgrade an existing route across a site to a small building. The options in such a case, from doing no work to upgrading certain features of the route e.g. a sharp bend, should be considered by the Building Control Body in consultation with the Fire and Rescue Service.

### Buildings not fitted with fire mains

**17.2** There should be vehicle access for a pump appliance to small buildings (those of up to 2000m<sup>2</sup> with a top storey up to 11m above ground level) to either:

- a. 15% of the perimeter; or
- b. within 45m (60m if provided with automatic fire suppression in line with Section 2) of every point on the projected plan area (or 'footprint', see Diagram 48) of the building; whichever is the less onerous.

**17.3** There should be vehicle access for a pump appliance to blocks of flats to within 60m of all points within each dwelling (45m if not provided with automatic fire suppression in line with Section 2).

**Note 1:** If the provisions in paragraph 17.2 or 17.3 cannot be met, a fire main should be provided in accordance with paragraph 16.3 and vehicle access should meet paragraph 17.6.

Section 17

<b>Table 19 Fire and rescue service vehicle access to buildings (excluding blocks of flats) not fitted with fire mains</b>			
<b>Total floor area <sup>(1)</sup> of building m<sup>2</sup></b>	<b>Height of floor of top storey above ground <sup>(2)</sup></b>	<b>Provide vehicle access <sup>(3)(4)</sup> to:</b>	<b>Type of appliance</b>
Up to 2000	Up to 11 Over 11	See paragraph 17.2 15% of perimeter <sup>(5)</sup>	Pump High reach
2000-8000	Up to 11 Over 11	15% of perimeter <sup>(5)</sup> 50% of perimeter <sup>(5)</sup>	Pump High reach
8000-16,000	Up to 11 Over 11	50% of perimeter <sup>(5)</sup> 50% of perimeter <sup>(5)</sup>	Pump High reach
16,000-24,000	Up to 11 Over 11	75% of perimeter <sup>(5)</sup> 75% of perimeter <sup>(5)</sup>	Pump High reach
Over 24,000	Up to 11 Over 11	100% of perimeter <sup>(5)</sup> 100% of perimeter <sup>(5)</sup>	Pump High reach

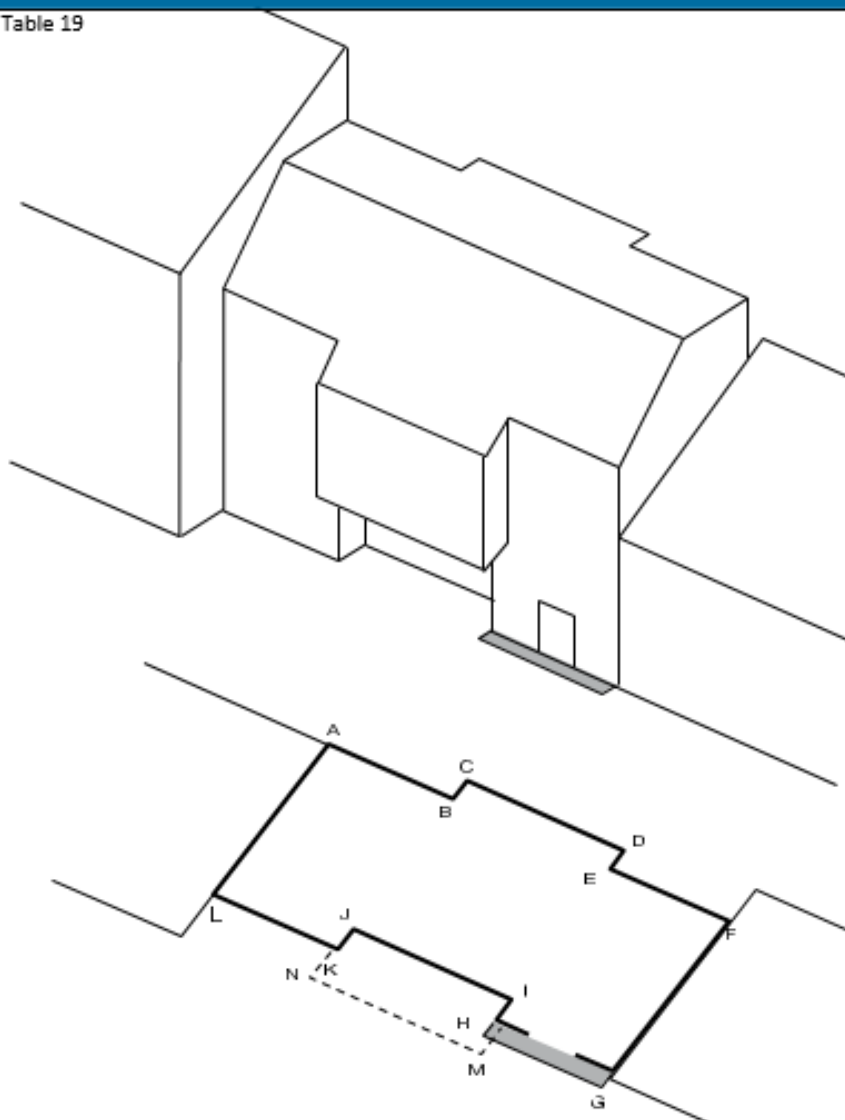
Notes:

1. The total floor area is the aggregate of all floors in the building (excluding basements).
2. In the case of Purpose Group 7(a) (storage) buildings, height should be measured to mean roof level, see Methods of measurement in Appendix C.
3. An access door is required to each such elevation (see paragraph 17.5).
4. See paragraph 17.8 for meaning of access.
5. Perimeter is described in Diagram 48.

Section 17

**Diagram 48 Example of building footprint and perimeter**

See para 17.2 and Table 19



Plan of building AFGL where AL and FG are walls in common with other buildings.

The footprint of the building is the maximum aggregate plan perimeter found by the vertical projection of any overhanging storey onto a ground storey (i.e. ABCDEFGHMNKL).

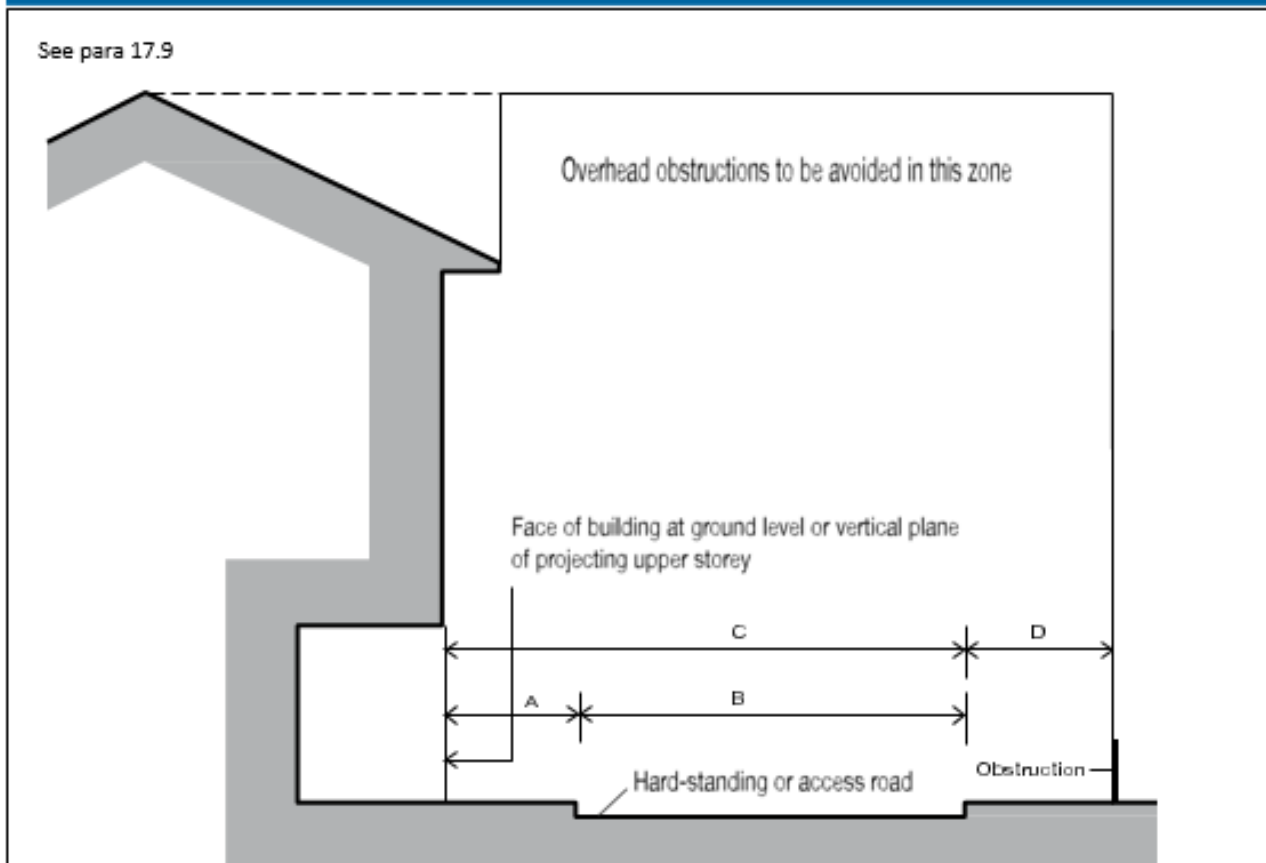
The perimeter of the building for the purposes of Table 20 is the sum of the lengths of the two external walls, taking account of the footprint i.e. (A to B to C to D to E to F) + (G to H to M to N to K to L).

If the dimensions of the building are such that Table 20 requires vehicle access, the shaded area illustrates one possible example of 15% of the perimeter. **Note:** There should be a door into the building in this length (see paragraph 17.5)

If the building does not have walls in common with other buildings, the lengths AL and FG would be included in the perimeter.

Section 17

**Diagram 49 Relationship between building and hardstanding/access road for high reach fire appliances**



	Type of appliance	
	Turntable ladder dimension (m)	Hydraulic platform dimension (m)
A. Maximum distance of near edge of hard-standing from building	4.9	2.0
B. Minimum width of hardstanding	5.0	5.5
C. Minimum distance of further edge of hard-standing from building	10.0	7.5
D. Minimum width of unobstructed space (for swing of appliance platform)	N/A	2.2
<b>Notes</b>		
1. Hard-standing for high reach appliances should be as level as possible and should not exceed a gradient of 1 in 12.		
2. Fire appliances are not standardised. Some fire services have appliances with a greater weight or different size. In consultation with the Fire and Rescue Service, the Building Control Body should adopt the relevant dimensions and ground loading capacity.		

**Section 17**

**17.4** Vehicle access to buildings that do not have fire mains (other than buildings described in paragraph 17.2) should be provided in accordance with Table 19.

**17.5** Every elevation to which vehicle access is provided in accordance with paragraph 17.2 or Table 19 should have a suitable door(s), not less than 750mm wide, giving access to the interior of the building

Door(s) should be provided such that there is no more than 60m between each door and/or the end of that elevation (e.g. a 150m elevation would need at least 2 doors).

<b>Table 20 Typical fire and rescue service vehicle access route specification</b>						
<b>Appliance type</b>	<b>Minimum width of road between kerbs (m)</b>	<b>Minimum width of gateways (m)</b>	<b>Minimum turning circle between kerbs (m)</b>	<b>Minimum turning circle between walls (m)</b>	<b>Minimum clearance height (m)</b>	<b>Minimum carrying capacity (tonnes)</b>
Pump	3.7	3.1	16.8	19.2	3.7	12.5
High reach	3.7	3.1	26.0	29.0	4.0	17.0

**Notes:**

1. Fire appliances are not standardised. Some fire services have appliances of greater weight or different size. In consultation with the Fire and Rescue Service, the Building Control Body may adopt other dimensions in such circumstances.
2. Because the weight of high reach appliances is distributed over a number of axles, it is considered that their infrequent use of a carriageway or route designed to 12.5 tonnes should not cause damage. It would therefore be reasonable to design the roadbase to 12.5 tonnes, although structures such as bridges should have the full 17 tonnes capacity.



## Section 17

### Buildings fitted with fire mains

- 17.6** In the case of a building fitted with dry fire mains there should be access for a pumping appliance to within 18m of each fire main inlet connection point, typically on the face of the building. The inlet should be visible from the appliance.
- 17.7** In the case of a building fitted with wet mains the pumping appliance access should be to within 18m and within sight of, a suitable entrance giving access to the main and in sight of the inlet for the emergency replenishment of the suction tank for the main.

**Note:** Where fire mains are provided in buildings for which Sections 16 and 18 make no provision, vehicle access may be to paragraph 17.6 or 17.7 rather than Table 19.

### Design of access routes and hard-standings

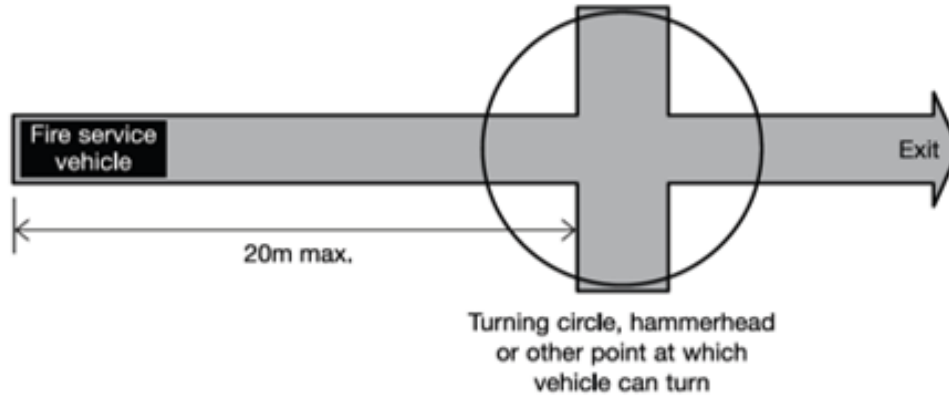
- 17.8** A vehicle access route may be a road or other route which, including any inspection covers and the like, meets the standards in Table 20 and the following paragraphs.
- 17.9** Where access is provided to an elevation in accordance with Table 19 for:
- a. buildings up to 11m in height (excluding buildings covered by paragraph 17.2(b)), there should be access for a pump appliance adjacent to the building for the percentage of the total perimeter specified;
  - b. buildings over 11m in height, the access routes should meet the guidance in Diagram 49.
- 17.10** Where access is provided to an elevation for high reach appliances in accordance with Table 19, overhead obstructions such as cables and branches that would interfere with the setting of ladders etc, should be avoided in the zone shown in Diagram 49.
- 17.11** Turning facilities should be provided in any dead-end access route that is more than 20m long (see Diagram 50). This can be by a hammerhead or turning circle, designed on the basis of Table 20.

Section 17

### Diagram 50 Turning facilities

See para 17.11

Fire and rescue service vehicles should not have to reverse more than 20m from the end of an access road



## Section 18

## B5

# Access to buildings for firefighting personnel

### Introduction

**18.1** In low-rise buildings without deep basements fire and rescue service personnel access requirements will be met by a combination of the normal means of escape and the measures for vehicle access in Section 17, which facilitate ladder access to upper storeys. In other buildings, the problems of reaching the fire and working inside near the fire, necessitate the provision of additional facilities to avoid delay and to provide a sufficiently secure operating base to allow effective action to be taken.

These additional facilities include firefighting lifts, firefighting stairs and firefighting lobbies, which are combined in a protected shaft known as the firefighting shaft (Diagram 52).

Guidance on protected shafts in general is given in Section 9.

**Note:** Because of the high degree of compartmentation in blocks of block of flats, the provisions for the design and construction of firefighting shafts is different to other buildings.

### Provision of firefighting shafts

- 18.2** Buildings with a floor at more than 18m above fire and rescue service vehicle access level, or with a basement at more than 10m below fire and rescue service vehicle access level, should be provided with firefighting shafts containing firefighting lifts (see Diagram 51).
- 18.3** Buildings in Purpose Groups 4, 5 and 6 with a storey of 900m<sup>2</sup> or more in area, where the floor is at a height of more than 7.5m above fire and rescue service vehicle access level, should be provided with firefighting shaft(s), which need not include firefighting lifts.
- 18.4** Buildings with two or more basement storeys, each exceeding 900m<sup>2</sup> in area, should be provided with firefighting shaft(s), which need not include firefighting lifts.
- 18.5** If a firefighting shaft is required to serve a basement it need not also serve the upper floors unless they also qualify because of the height or size of the building. Similarly a shaft serving upper storeys need not serve a basement which is not large or deep enough to qualify in its own right. However, a firefighting stair and any firefighting lift should serve all intermediate storeys between the highest and lowest storeys that they serve.

## Section 18

- 18.6** Firefighting shafts should serve all floors through which they pass.
- 18.7** Shopping complexes should be provided with firefighting shafts in accordance with the recommendations of Section 4 of BS 5588-10:1991.

### Number and location of firefighting shafts

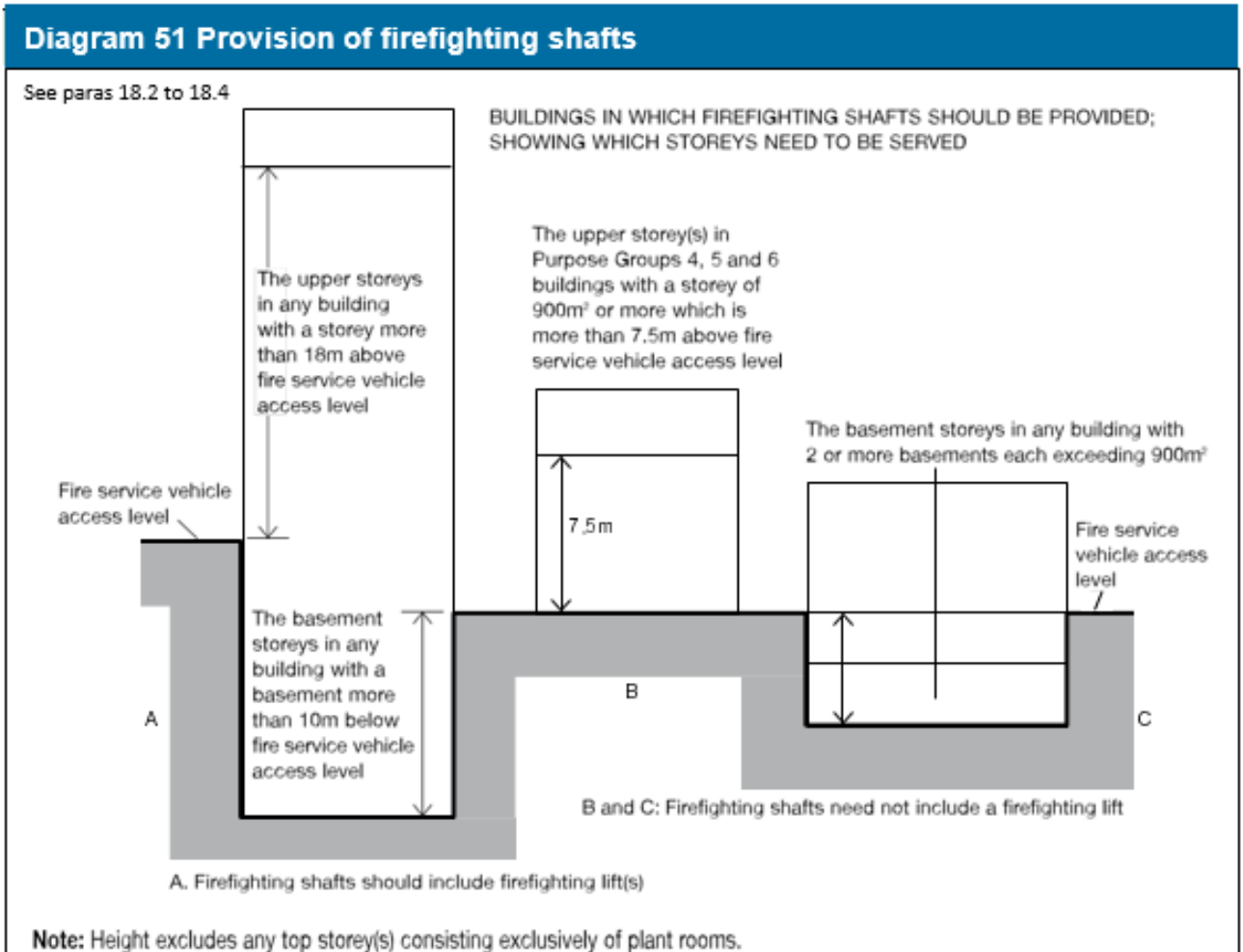
- 18.8** Fire fighting shafts should be located to meet the maximum hose distances set out on paragraph 18.9 or 18.10 and at least two should be provided in buildings with a storey of 900m<sup>2</sup> or more in area, where the floor is at a height of more than 18m above fire and rescue service vehicle access level (or above 7.5m where covered by paragraph 18.3)
- 18.9** If the building is fitted throughout with an automatic fire suppression system in accordance with section 2, then sufficient firefighting shafts should be provided such that every part of every storey, that is more than 18m above fire and rescue service vehicle access level (or above 7.5m where covered by paragraph 18.3), is no more than 60m from a fire main outlet in a firefighting shaft, measured on a route suitable for laying hose.
- 18.10** If the building is not fitted with automatic fire suppression system then every part of every storey that is more than 18m above fire and rescue service vehicle access level (or above 7.5m where covered by paragraph 18.3), should be no more than 45m from a fire main outlet contained in a protected stairway and 60m from a fire main in a firefighting shaft, measured on a route suitable for laying hose.

**Note:** In order to meet the 45m hose criterion it may be necessary to provide additional fire mains in escape stairs. This does not imply that these stairs need to be designed as firefighting shafts.

### Design and construction of firefighting shafts

- 18.11** Except in blocks of flats (see paragraph 18.14), every firefighting stair and firefighting lift should be approached from the accommodation, through a firefighting lobby.
- 18.12** All firefighting shafts should be equipped with fire mains having outlet connections and valves at every storey.
- 18.13** A firefighting lift installation includes the lift car itself, the lift well and the lift machinery space, together with the lift control system and the lift communications system. The shaft should be constructed generally in accordance with clauses 7 and 8 of BS 5588-5:2004. Firefighting lift installations should conform to BS EN 81-72:2003 and to BS EN 81-1:1998 or BS EN 81-2:1998 as appropriate for the particular type of lift.

Section 18



### Variations for block of flats

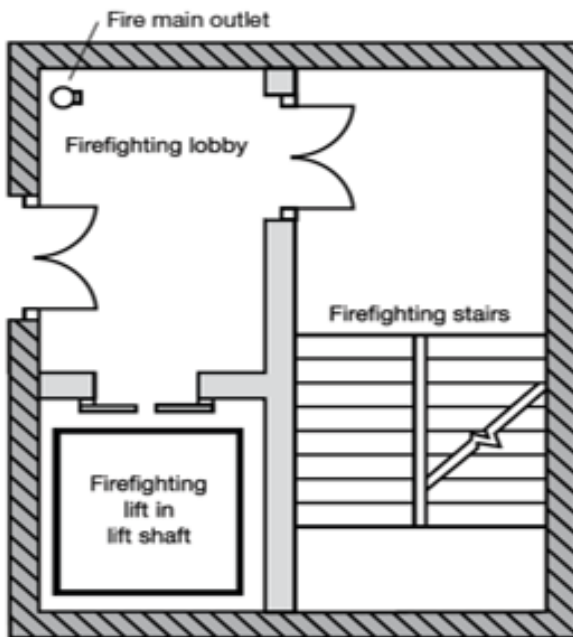
**18.14** Where the design of means of escape in case of fire and compartmentation in blocks of flats has followed the guidance in Sections 4 and 10, the addition of a firefighting lobby between the firefighting stair(s) and the protected corridor or lobby provided for means of escape purposes is not necessary. Similarly, the firefighting lift can open directly into such protected corridor or lobby, but the firefighting lift landing doors should not be more than 7.5m from the door to the firefighting stair.

Section 18

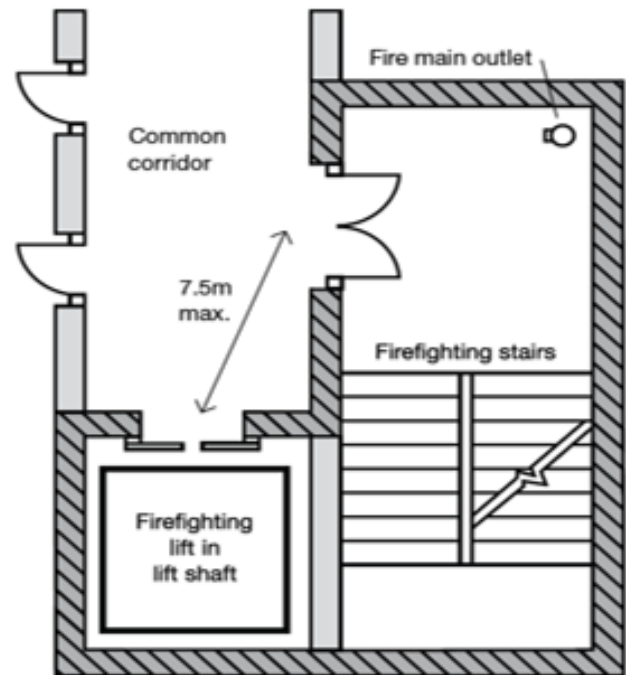
**Diagram 52 Components of a firefighting shaft**

See para 18.1

a. Any building



b. Shafts serving flats



- Minimum fire resistance 60 minutes from both sides with 30 minute fire doors
- ▨ Minimum fire resistance 120 minutes from accommodation side and 60 minutes from inside the shaft with 60 minute fire doors

**Notes:**

1. Outlets from a fire main should be located in the firefighting lobby or, in the case of a shaft serving flats, in the firefighting stairway (see Diagram b).
2. Smoke control should be provided in accordance with BS 5588-5:2004 or, where the shaft only serves flats, the provisions for smoke control given in paragraph 3.25 may be followed instead.
3. A firefighting lift is required if the building has a floor more than 18m above, or more than 10m below, fire service vehicle access level.
4. This Diagram is only to illustrate the basic components and is not meant to represent the only acceptable layout. The shaft should be constructed generally in accordance with clauses 7 and 8 of BS 5588-5:2004.

**Rolling shutters in compartment walls**

**18.15** Rolling shutters should be capable of being opened and closed manually by the fire and rescue service without the use of a ladder.

## Section 19

## B5

# Venting of heat and smoke from basements

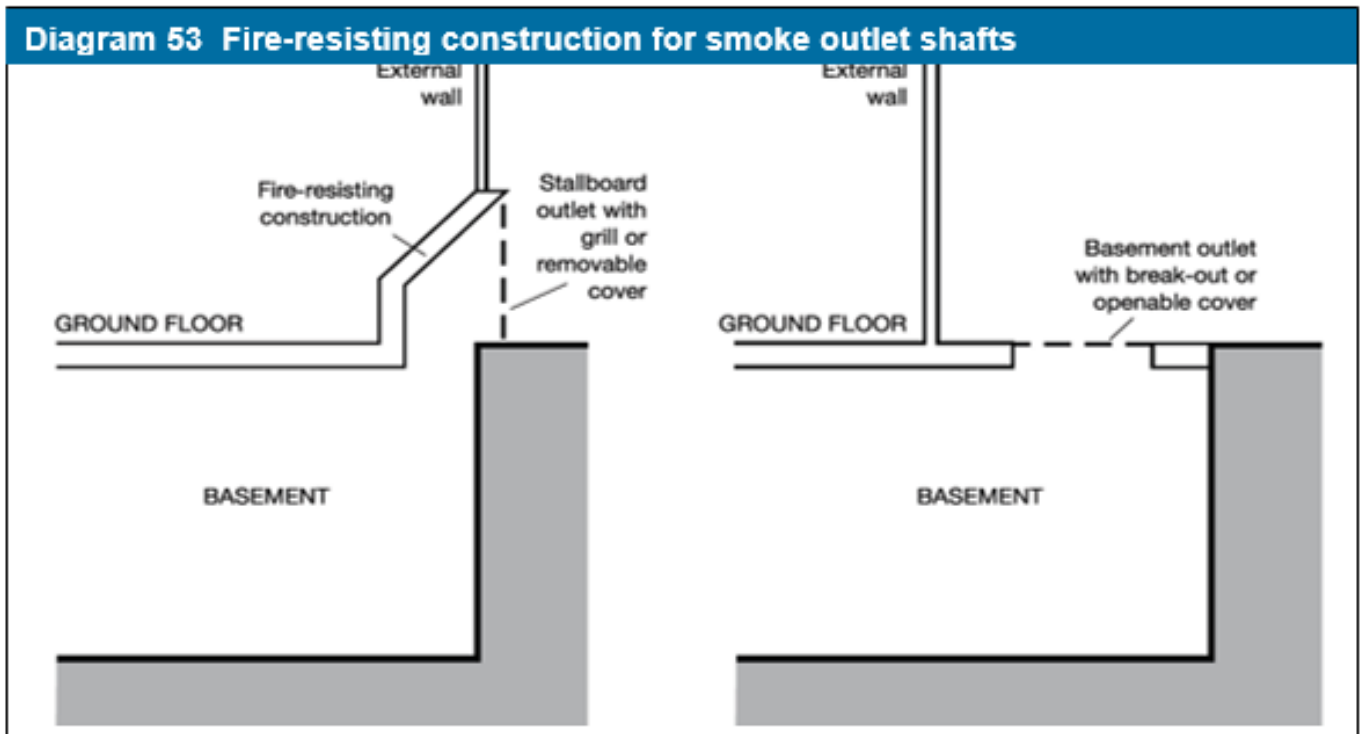
### Introduction

- 19.1** The build-up of smoke and heat as a result of a fire can seriously inhibit the ability of the fire and rescue service to carry out rescue and firefighting operations in a basement. The problem can be reduced by providing facilities to make conditions tenable for firefighters.
- 19.2** Smoke outlets (also referred to as smoke vents) provide a route for heat and smoke to escape to the open air from the basement level(s). They can also be used by the fire and rescue service to let cooler air into the basement(s). (See Diagram 53.)

### Provision of smoke outlets

- 19.3** Where practicable each basement space should have one or more smoke outlets, but it is not always possible to do this where, for example the plan is deep and the amount of external wall is restricted by adjoining buildings. It is therefore acceptable to vent spaces on the perimeter and allow other spaces to be vented indirectly by opening connecting doors. However if a basement is compartmented, each compartment should have direct access to venting, without having to open doors etc into another compartment.
- 19.4** Smoke outlets, connected directly to the open air, should be provided from every basement storey, except for any basement storey that has:
- a floor area of not more than 200m<sup>2</sup> and
  - a floor not more than 3m below the adjacent ground level.
- 19.5** Strong rooms need not be provided with smoke outlets.

Section 19





## Section 19

- 19.6** Where basements have external doors or windows, the compartments containing the rooms with these doors or windows do not need smoke outlets. It is common for basements to be open to the air on one or more elevations. This may be the result of different ground levels on different sides of the building. It is also common in 18th and 19th century terraced housing where an area below street level is excavated at the front and/or rear of the terrace so that the lowest storey has ordinary windows and sometimes an external door.

### Natural smoke outlets

- 19.7** Smoke outlets should be sited at high level, either in the ceiling or in the wall of the space they serve. They should be evenly distributed around the perimeter to discharge in the open air outside the building.
- 19.8** The combined clear cross-sectional area of all smoke outlets should not be less than 1/40th of the floor area of the storey they serve.
- 19.9** Separate outlets should be provided from places of special fire hazard.
- 19.10** If the outlet terminates at a point that is not readily accessible, it should be kept unobstructed and should only be covered with a non-combustible grille or louvre.
- 19.11** If the outlet terminates in a readily accessible position, it may be covered by a panel, stallboard or pavement light which can be broken out or opened. The position of such covered outlets should be suitably indicated.
- 19.12** Outlets should not be placed where they would prevent the use of escape routes from the building.

### Mechanical smoke extract

- 19.13** A system of mechanical extraction may be provided as an alternative to natural venting to remove smoke and heat from basements, provided that the basement storey(s) are fitted with an automatic fire suppression system in accordance with section 2. (It is not considered necessary in this particular case to install an automatic fire suppression system on the storeys other than the basement(s) unless they are needed for other reasons for example regulation 37A.)

**Note:** Car parks are not normally expected to be fitted with an automatic fire suppression system (see paragraph 12.2).

- 19.14** The air extraction system should give at least 10 air changes per hour and should be capable of handling gas temperatures of 300°C for not less than one hour. It should come into operation automatically on activation of the automatic fire suppression system; alternatively activation may be by an automatic fire detection system which conforms to BS 5839-1:2002 (at least L3 standard). For further information on equipment for removing hot smoke refer to BS EN 12101-3:2002.

## Section 19

### Construction of outlet ducts or shafts

- 19.15** Outlet ducts or shafts, including any bulkheads over them (see Diagram 53), should be enclosed in non-combustible construction having not less fire resistance than the element through which they pass.
- 19.16** Where there are natural smoke outlet shafts from different compartments of the same basement storey, or from different basement storeys, they should be separated from each other by non-combustible construction having not less fire resistance than the storey(s) they serve.

### Basement car parks

- 19.17** The provisions for ventilation of basement car parks in Section 12 may be taken as satisfying the requirements in respect of the need for smoke venting from any basement that is used as a car park.

# Appendix A

---

## Performance of materials, products and structures

### Introduction

1. Much of the guidance in this document is given in terms of performance classifications in relation to British or European Standards. In such cases, it will be necessary to demonstrate that a system or product can meet the relevant performance classification.
  - a. This will be achieved if the system or product complies with one of the following:
    - i. They should be in accordance with a specification or design that has been shown by specific test to be capable of meeting that performance classification.
    - ii. They should have been designed by using relevant design standards in order to meet that performance classification.
    - iii. They should have been assessed by applying the relevant test evidence, in lieu of carrying out a specific test, as being capable of meeting that performance classification.

**Note:** Some products are subject to Classification Without Further Testing (CWFT). For the purposes of this approved document, such products can be considered to have been shown to be capable of meeting a performance specification as per paragraph 1a.i. above.

- b. Any test evidence used to demonstrate the fire performance classification of a product or system should be carefully checked to ensure that it is applicable to the intended use. Small differences in detail, such as fixing method, joints, dimensions, the introduction of insulation materials and air gaps (ventilated or not), can significantly affect the performance.
- c. Assessments should not be regarded as a way to avoid a test where one is necessary. They should only be carried out where sufficient relevant test evidence is available. Relevant test evidence is unlikely to be provided by test standards which have different classification criteria.
- d. Where it is proposed to assess the classification of a product or system in lieu of carrying out a specific test (as in paragraph a.ii. above), this should be done in accordance with the relevant standard for extended application for the test in question and should include details of the test evidence that has been used to support the assessment.

## Appendix A

- e. For performance classifications where there is no specific standard for extended application, assessment reports should be produced in accordance with the principles of BS EN 15725 and should include details of the test evidence that has been used to support the assessment. Further information on best practice is provided in the Passive Fire Protection Federation's Guide to undertaking technical assessments of the fire performance of construction products based on fire test evidence

**Note:** Regulation 7(2) limits components used in or on the external walls of certain buildings to materials achieving European classification Class A2-s1, d0 or Class A1 (see Section 13). Assessments cannot be used to demonstrate compliance with this requirement.

2. Tests and assessments should be carried out by organisations with the necessary expertise. For example, organisations listed as "notified bodies" in accordance with the European Construction Products Regulation or laboratories accredited by the United Kingdom Accreditation Service (UKAS) for the relevant test standard can be assumed to have the necessary expertise.

**Note:** Standard fire tests do not directly measure fire hazard. They measure or assess the response of a material or system to exposure to one or more aspects of fire conditions. Performance in fire tests is only one of a number of factors that should be taken into account.

## Fire resistance

3. Factors having a bearing on fire resistance that are considered in this document are:
  - a. fire severity;
  - b. building height; and
  - c. building occupancy.
4. The standards of fire resistance given are based on assumptions about the severity of fires and the consequences should an element fail. Fire severity is estimated in very broad terms from the use of the building (its purpose group), on the assumption that the building contents (which constitute the fire load) are similar for buildings in the same use.

A number of factors affect the standard of fire resistance specified. These are:

- a. the amount of combustible material per unit of floor area in various types of building (the fire load density);
- b. the height of the top floor above ground, which affects the ease of escape and of firefighting operations and the consequences should large scale collapse occur;
- c. occupancy type, which reflects the ease with which the building can be evacuated quickly;
- d. whether there are basements, because the lack of an external wall through which to vent heat and smoke may increase heat build-up and thus affect the duration of a fire, as well as complicating firefighting; and

## Appendix A

- e. whether the building is of single storey construction (where escape is direct and structural failure is unlikely to precede evacuation).

Because the use of buildings may change, a precise estimate of fire severity based on the fire load due to a particular use may be misleading. Therefore if a fire engineering approach of this kind is adopted the likelihood that the fire load may change in the future needs to be considered.

5. Performance in terms of the fire resistance to be met by elements of structure, doors and other forms of construction is determined by reference to either:
  - a. (National tests) BS 476 *Fire tests on building materials and structures*, Parts 20-24: 1987, i.e. Part 20 *Method for determination of the fire resistance of elements of construction (general principles)*, Part 21 *Methods for determination of the fire resistance of loadbearing elements of construction*, Part 22 *Methods for determination of the fire resistance of non-loadbearing elements of construction*, Part 23 *Methods for determination of the contribution of components to the fire resistance of a structure* and Part 24 *Method for determination of the fire resistance of ventilation ducts* (or to BS 476-8:1972 in respect of items tested or assessed prior to 1 January 1988); or
  - b. (European tests) Commission Decision 2000/367/EC of 3rd May 2000 implementing Council Directive 89/106/EEC as regards the classification of the resistance to fire performance of construction products, construction works and parts thereof.

**Note:** The latest version of any standard may be used provided that it continues to address the relevant requirements of the Regulations.

All products are classified in accordance with BS EN 13501-2:2007, *Fire classification of construction products and building elements – Classification using data from fire resistance tests (excluding products for use in ventilation systems)*.

BS EN 13501-3:2005, *Fire classification of construction products and building elements – Classification using data from fire resistance tests on components of normal building service installations (other than smoke control systems)*.

BS EN 13501-4:2007, *Fire classification of construction products and building elements – Classification using data from fire resistance tests on smoke control systems*. The relevant European test methods under BS EN 1364, 1365, 1366 and 1634 are listed in Appendix G.

**Table A1 gives the specific requirements for each element in terms of one or more of the following performance criteria:**

- a. **resistance to collapse** (loadbearing capacity), which applies to loadbearing elements only, denoted R in the European classification of the resistance to fire performance;

## Appendix A

- b. **resistance to fire penetration** (integrity), denoted E in the European classification of the resistance to fire performance; and
- c. **resistance to the transfer of excessive heat** (insulation), denoted I in the European classification of the resistance to fire performance.

**Table A2 sets out the minimum periods of fire resistance for elements of structure.**

**Table A3 sets out criteria appropriate to the suspended ceilings that can be accepted as contributing to the fire resistance of a floor.**

**Table A4 sets out limitations on the use of uninsulated fire-resisting glazed elements.**

**These limitations do not apply to the use of insulated fire-resisting glazed elements.**

Information on tested elements is frequently given in literature available from manufacturers and trade associations.

Information on tests on fire-resisting elements is also given in such publications as: Association for Specialist *Fire Protection Fire protection for structural steel in buildings 4th Edition* (ISBN: 1 87040 925 6).

## Roofs

6. Performance in terms of the resistance of roofs to external fire exposure is determined by reference to either:
  - a. (National tests) BS 476-3:2004 *External fire exposure roof tests*; or
  - b. (European tests) Commission Decision 2005/823/EC amending Decision 2001/671/EC establishing a classification system for the external fire performance of roofs and roof coverings.

Constructions are classified within the National system by 2 letters in the range A to D, with an AA designation being the best. The first letter indicates the time to penetration; the second letter a measure of the spread of flame.

Constructions are classified within the European system as B<sub>ROOF</sub>(t4), C<sub>ROOF</sub>(t4), D<sub>ROOF</sub>(t4), E<sub>ROOF</sub>(t4) or F<sub>ROOF</sub>(t4) (with B<sub>ROOF</sub>(t4) being the highest performance and F<sub>ROOF</sub>(t4) being the lowest) in accordance with BS EN 13501-5:2005, *Fire classification of construction products and building elements – Classification using test data from external fire exposure to roof tests*.

BS EN 13501-1 refers to four separate tests. The suffix (t4) used above indicates that Test 4 is to be used for the purposes of this Approved Document.

Some roof covering products (and/or materials) can be considered to fulfil all of the requirements for the performance characteristic “external fire performance” without the

## Appendix A

need for testing, subject to any national provisions on the design and execution of works being fulfilled. These roof covering products are listed in Commission Decision 2000/553/EC of 6th September 2000 implementing Council Directive 89/106/EEC as regards the external fire performance of roof coverings.

In some circumstances roofs, or parts of roofs, may need to be fire-resisting, for example if used as an escape route or if the roof performs the function of a floor. Such circumstances are covered in Sections 3, 5 and 7.

### **Table A5 gives notional designations of some generic roof coverings.** **Reaction to fire**

7. Performance in terms of reaction to fire to be met by construction products is determined by Commission Decision 200/147/EC of 8th February 2000 implementing Council Directive 89/106/EEC as regards the classification of the reaction to fire performance of construction products.

**Note:** The latest version of any standard may be used provided that it continues to address the relevant requirements of the Regulations.

All products, excluding floorings, are classified as †A1, A2, B, C, D, E or F (with class A1 being the highest performance and F being the lowest) in accordance with BS EN 13501-1:2018, *Fire classification of construction products and building elements, Part 1 – Classification using data from reaction to fire tests*.

The relevant European test methods are specified as follows,

BS EN ISO 1182:2002, *Reaction to fire tests for building products – Non-combustibility test*.

BS EN ISO 1716:2002, *Reaction to fire tests for building products – Determination of the gross calorific value*.

BS EN 13823:2002, *Reaction to fire tests for building products – Building products excluding floorings exposed to the thermal attack by a single burning item*.

BS EN ISO 11925-2:2002, *Reaction to fire tests for building Products, Part 2 – Ignitability when subjected to direct impingement of a flame*.

BS EN 13238:2001, *Reaction to fire tests for building products – conditioning procedures and general rules for selection of substrates*.

### **Non-combustible materials**

8. Non-combustible materials are defined in Table A6 either as listed products, or in terms of performance:
- a. (National classes) when tested to BS 476-4:1970 *Non-combustibility test for materials* or BS 476-11:1982 *Method for assessing the heat emission from building products*; or

## Appendix A

- b. (European classes) when classified as class A1 in accordance with BS EN 13501-1:2018, *Fire classification of construction products and building elements, Part 1-Classification using data from reaction to fire tests* when tested to BS EN ISO 1182:2002, *Reaction to fire tests for building products – Non- combustibility test* and BS EN ISO 1716:2002 *Reaction to fire tests for building products – Determination of the gross calorific value*.

**Table A6 identifies non-combustible products and materials and lists circumstances where their use is necessary.**

### Materials of limited combustibility

9. Materials of limited combustibility are defined in Table A7:

- a. (National classes) by reference to the method specified in BS 476: Part 11:1982; or
- b. (European classes) in terms of performance when classified as class A2-s3, d2 in accordance with BS EN 13501-1:2018, *Fire classification of construction products and building elements, Part 1 – Classification using data from reaction to fire tests* when tested to BS EN ISO 1182:2002, *Reaction to fire tests for building products – Non- combustibility test* or BS EN ISO 1716:2002 *Reaction to fire tests for building products – Determination of the gross calorific value* and BS EN 13823:2002, *Reaction to fire tests for building products – Building products excluding floorings exposed to the thermal attack by a single burning item*.

**Table A7 also includes composite products (such as plasterboard) which are considered acceptable and where these are exposed as linings they should also meet any appropriate flame spread rating.**  
**Internal linings**

10. Flame spread over wall or ceiling surfaces is controlled by providing for the lining materials or products to meet given performance levels in tests appropriate to the materials or products involved.
11. Under the National classifications, lining systems which can be effectively tested for 'surface spread of flame' are rated for performance by reference to the method specified in BS 476-7:1971 *Surface spread of flame tests for materials, or 1987 Method for classification of the surface spread of flame of products, or 1997 Method of test to determine the classification of the surface spread of flame of products* under which materials or products are classified 1, 2, 3 or 4 with Class 1 being the highest.

Under the European classifications, lining systems are classified in accordance with BS EN 13501-1:2018, *Fire classification of construction products and building elements, Part 1 – Classification using data from reaction to fire tests*. Materials or products are classified as A1, A2, B, C, D, E or F, with A1 being the highest. When a classification includes "s3, d2", it means that there is no limit set for smoke production and/or flaming droplets/particles.



## Appendix A

† The classes of reaction to fire performance of A2, B, C, D and E are accompanied by additional classifications related to the production of smoke (s1, s2, s3) and/or flaming droplets/particles (d0, d1, d2).

12. To restrict the use of materials which ignite easily, which have a high rate of heat release and/ or which reduce the time to flashover, maximum acceptable 'fire propagation' indices are specified, where the National test methods are being followed.

These are determined by reference to the method specified in BS 476-6:1981 or 1989 *Method of test for fire propagation of products*. Index of performance (I) relates to the overall test performance, whereas sub-index (i1) is derived from the first three minutes of test.

13. The highest National product performance classification for lining materials is Class 0. This is achieved if a material or the surface of a composite product is either:
- composed throughout of materials of limited combustibility; or
  - a Class 1 material which has a fire propagation index (I) of not more than 12 and sub-index (i1) of not more than 6.

**Note:** Class 0 is not a classification identified in any British Standard test.

14. Composite products defined as materials of limited combustibility (see paragraph 12 above and Table A7) should in addition comply with the test requirement appropriate to any surface rating specified in the guidance on requirements B2, B3 and B4.
15. The notional performance ratings of certain widely used generic materials or products are listed in Table A8 in terms of their performance in the traditional lining tests BS 476 Parts 6 and 7 or in accordance with BS EN 13501-1:2018, *Fire classification of construction products and building elements, Part 1 – Classification using data from reaction to fire tests*.
16. Results of tests on proprietary materials are frequently given in literature available from manufacturers and trade associations.

Any reference used to substantiate the surface spread of flame rating of a material or product should be carefully checked to ensure that it is suitable, adequate and applicable to the construction to be used. Small differences in detail, such as thickness, substrate, colour, form, fixings, adhesive etc, may significantly affect the rating.

## Thermoplastic materials

17. A thermoplastic material means any synthetic polymeric material which has a softening point below 200°C if tested to BS EN ISO 306:2004 method A120 *Plastics – Thermoplastic materials – Determination of Vicat softening temperature*. Specimens for this test may be fabricated from the original polymer where the thickness of material of the end product is less than 2.5mm.

## Appendix A

18. A thermoplastic material in isolation cannot be assumed to protect a substrate, when used as a lining to a wall or ceiling. The surface rating of both products must therefore meet the required classification. If however, the thermoplastic material is fully bonded to a non-thermoplastic substrate, then only the surface rating of the composite will need to comply.
19. Concessions are made for thermoplastic materials used for window glazing, rooflights and lighting diffusers within suspended ceilings, which may not comply with the criteria specified in paragraphs 14 onwards.

They are described in the guidance on requirements B2 and B4.

20. For the purposes of the requirements B2 and B4 thermoplastic materials should either be used according to their classification 0-3, under the BS 476: Parts 6 and 7 tests as described in paragraphs 14 onwards, (if they have such a rating), or they may be classified TP(a) rigid, TP(a) flexible, or TP(b) according to the following methods:

### TP(a) rigid:

- i. rigid solid PVC sheet;
- ii. solid (as distinct from double- or multiple-skin) polycarbonate sheet at least 3mm thick;
- iii. multi-skinned rigid sheet made from unplasticised PVC or polycarbonate which has a Class 1 rating when tested to BS 476-7:1971, 1987 or 1997; or
- iv. any other rigid thermoplastic product, a specimen of which (at the thickness of the product as put on the market), when tested to BS 2782-0:2004 Method 508A *Rate of burning, Laboratory method*, performs so that the test flame extinguishes before the first mark and the duration of flaming or afterglow does not exceed 5 seconds following removal of the burner.

### TP(a) flexible:

Flexible products not more than 1mm thick which comply with the Type C requirements of BS 5867-2:1980 *Specification for fabrics for curtains and drapes – Flammability requirements* when tested to BS 5438:1989 *Methods of test for flammability of textile fabrics when subjected to a small igniting flame applied to the face or bottom edge of vertically oriented specimens*, Test 2, with the flame applied to the surface of the specimens for 5, 15, 20 and 30 seconds respectively, but excluding the cleansing procedure; and

### TP(b):

- i. rigid solid polycarbonate sheet products less than 3mm thick, or multiple-skin polycarbonate sheet products which do not qualify as TP(a) by test; or
- ii. other products which, when a specimen of the material between 1.5 and 3mm thick is tested in accordance with BS 2782-0:2004 Method 508A, has a rate of burning which does not exceed 50mm/minute.

**Note:** If it is not possible to cut or machine a 3mm thick specimen from the product then a 3mm test specimen can be moulded from the same material as that used for the manufacture of the product.

## Appendix A

**Note:** Currently, no new guidance is possible on the assessment or classification of thermoplastic materials under the European system since there is no generally accepted European test procedure and supporting comparative data.

### Fire test methods

21. A guide to the various test methods in BS 476 and BS 2782 is given in PD 6520: *Guide to fire test methods for building materials and elements of construction* (available from the British Standards Institution).

A guide to the development and presentation of fire tests and their use in hazard assessment is given in BS 6336:1998 *Guide to development and presentation of fire tests and their use in hazard assessment*.

Appendix A

<b>Table A1 Specific provisions of test for fire resistance of elements of structure etc</b>					
<b>Part of building</b>	<b>Minimum provisions when tested to the relevant part of BS 476 <sup>(1)</sup> (minutes)</b>			<b>Minimum provisions when tested to the relevant European standard (minutes) <sup>(9)</sup></b>	<b>Method of exposure</b>
	<b>Loadbearing capacity <sup>(2)</sup></b>	<b>Integrity</b>	<b>Insulation</b>		
1. <b>Structural</b> frame, beam or column	See Table A2	Not applicable	Not applicable	R see Table A2	Exposed faces
2. <b>Loadbearing wall</b> (which is not also a wall described in any of the following items)	See Table A2	Not applicable	Not applicable	R see Table A2	Each side separately
3. <b>Floors</b> <sup>(3)</sup> a. between a shop and flat above	60 or see Table A2 (whichever is greater)	60 or see Table A2 (whichever is greater)	60 or see Table A2 (whichever is greater)	REI 60 or see Table A2 (whichever is greater)	From underside <sup>(4)</sup>
b. Any other floor – including compartment floors	See Table A2	See Table A2	See Table A2	REI see Table A2	
4. <b>Roofs</b> a. any part forming an escape route; b. any roof that performs the function of a floor	30 See Table A2	30 See Table A2	30 See Table A2	REI 30 REI see Table A2	From underside <sup>(4)</sup>
5. <b>External walls</b> a. any part less than 1000mm from any point on the relevant boundary <sup>(5)</sup>	See Table A2	See Table A2	See Table A2	REI see Table A2	Each side separately
b. any part 1000mm or more from the relevant boundary <sup>(5)</sup>	See Table A2	See Table A2	15	RE see Table A2 and REI 15	From inside the building
c. any part adjacent to an external escape route (see Section 6 Diagram 25)	30	30	No provision <sup>(6)(7)</sup>	RE30	From inside the building
6. <b>Compartment walls</b> Separating a. a flat from any other part of the building (see 9.13) b. occupancies (see 9.18f)	60 or see Table A2 (whichever is less)	60 or see Table A2 (whichever is less)	60 or see Table A2 (whichever is less)	REI 60 or see Table A2 (whichever is less)	Each side separately
7. <b>Compartment walls</b> (other than in item 6)	See Table A2	See Table A2	See Table A2	REI see Table A2	Each side separately

**Table A1 Specific provisions of test for fire resistance of elements of structure etc**

Part of building	Minimum provisions when tested to the relevant part of BS 476 <sup>(1)</sup> (minutes)			Minimum provisions when tested to the relevant European standard (minutes) <sup>(9)</sup>	Method of exposure
	Loadbearing capacity <sup>(2)</sup>	Integrity	Insulation		
<b>8. Protected shafts</b> Excluding any firefighting shaft a. any glazing described in Section 9, Diagram 32; b. any other part between the shaft and a protected lobby/corridor described in Diagram 32 above. c. any part not described in (a) or (b) above.	Not applicable	30	No provision <sup>(7)</sup>	E30	Each side separately
	30	30	30	REI 30	
	See Table A2	See Table A2	See Table A2	REI see Table A2	
<b>9. Enclosure</b> (which does not form part of a compartment wall or a protected shaft) to a: a. protected stairway: b. lift shaft	30	30	30 <sup>(8)</sup>	REI 30 <sup>(8)</sup>	Each side separately
	30	30	30	REI 30	
<b>10. Firefighting shafts</b>  a. construction separating firefighting shaft from rest of building;  b. construction separating firefighting stair, firefighting lift shaft and firefighting lobby	120	120	120	REI 120	From side remote from shaft
	60	60	60	REI 60	From shaft side
	60	60	60	REI 60	Each side separately
<b>11. Enclosure</b> (which is not a compartment wall or describe in item 8) to a: a. protected lobby; b. protected corridor	30	30	30 <sup>(8)</sup>	REI 30 <sup>(8)</sup>	Each side separately
	30	30	30 <sup>(8)</sup>	REI 30 <sup>(8)</sup>	
<b>12. Sub-division of a corridor</b>	30	30	30 <sup>(8)</sup>	REI 30 <sup>(8)</sup>	Each side separately
<b>13. Fire-resisting construction:</b>  a. enclosing places of special fire hazard (see 8.12);	30	30	30	REI 30	Each side separately

**Table A1 Specific provisions of test for fire resistance of elements of structure etc**

Part of building	Minimum provisions when tested to the relevant part of BS 476 <sup>(1)</sup> (minutes)			Minimum provisions when tested to the relevant European standard (minutes) <sup>(9)</sup>	Method of exposure
	Loadbearing capacity <sup>(2)</sup>	Integrity	Insulation		
b. between store rooms and sales area in shops (see 5.58)	30	30	30	REI 30	
c. fire-resisting subdivision described in Section 3, Diagram 16(b)	30	30	30	REI 30	
d. enclosing bedrooms an ancillary accommodation in care homes (see 4.48 and 4.50)	30	30	30	REI 30	
14. <b>Enclosure</b> In a flat to a protected entrance hall, or to a protected landing.	30	30	30(8)	REI 30 (8)	Each side separately
15. <b>Cavity barrier</b>	Not applicable	30	15	E 30 and EI 15	Each side separately
16. <b>Ceiling</b> Diagram 35	Not applicable	30	30	EI 30	From underside
17. <b>Duct</b> described in paragraph 10.16e	Not applicable	30	No provision	E 30	From outside
18. <b>Casing</b> around a drainage system described in Section 11, Diagram 38	Not applicable	30	No provision	E 30	From outside
19. <b>Flue walls</b> described in Section 11, Diagram 39	Not applicable	Half the period specified in Table A2 for the compartment wall/floor	Half the period specified in Table A2 for the compartment wall/floor	EI half the period specified in Table A2 for the compartment wall/floor	From outside
20. <b>Fire doors</b>		See Table B1		See Table B1	

**Notes:**

- Part 21 for loadbearing elements, Part 22 for non-loadbearing elements, Part 23 for fire-protecting suspended ceilings, and Part 24 for ventilation ducts. BS 476-8 results are acceptable for items tested or assessed before 1 January 1988.
- Applies to loadbearing elements only (see B3.ii and Appendix E).
- Guidance on increasing the fire resistance of existing timber floors is given in BRE Digest 208 *Increasing the fire resistance of existing timber floors* (BRE 1988).

4. A suspended ceiling should only be relied on to contribute to the fire resistance of the floor if the ceiling meets the appropriate provisions given in Table A3.
  5. The guidance in Section 13 allows such walls to contain areas which need not be fire-resisting (unprotected areas).
  6. Unless needed as part of a wall in item 5a or 5b.
  7. Except for any limitations on glazed elements given in Table A4.
  8. See Table A4 for permitted extent of uninsulated glazed elements.
  9. The National classifications do not automatically equate with the equivalent classifications in the European column, therefore products cannot typically assume a European class unless they have been tested accordingly. 'R' is the European classification of the resistance to fire performance in respect of loadbearing capacity; 'E' is the European classification of the resistance to fire performance in respect of integrity; and 'I' is the European classification of the resistance to fire performance in respect of insulation.
-

Appendix A

**Table A2 minimum periods of fire resistance**

Purpose group of building	Minimum provisions when tested to the relevant part of BS 476 <sup>(1)</sup> (minutes)					
	Basement storey <sup>§</sup> including floor over		Ground or upper storey			
	Depth (m) of a lowest basement		Height (m) of top floor above ground, in a building or separated part of a building			
	More than 10 <sup>(2)</sup>	Not more than 10	Not more than 5	Not more than 18	Not more than 30	More than 30
1. Residential:						
a. Block of flats						
- not sprinklered	90	60	30*	60**+	90**	Not permitted
- sprinklered	90	60	30*	60**+	90**	120**
b. Institutional	90	60	30*	60	90	120#
c. Other residential	90	60	30*	60	90	120#
2. Office						
- not sprinklered	90	60	30*	60	90	Not permitted
- sprinklered <sup>(2)</sup>	60	60	30*	30**	60	120
3. Shop and commercial:						
- not sprinklered	90	60	60	60	90	Not permitted
- sprinklered <sup>(2)</sup>	60	60	30*	60	60	120#
4. Assembly and recreation:						
- not sprinklered	90	60	60	60	90	Not permitted
- sprinklered <sup>(2)</sup>	60	60	30*	60	60	120#
5. Industrial:						
- not sprinklered	120	90	60	90	120	Not permitted
- sprinklered <sup>(2)</sup>	90	60	30*	60	90	120#
6. Storage and other non-residential:						
a. any building or part not described elsewhere:						
- not sprinklered	120	90	60	90	120	Not permitted
- sprinklered (2)	90	60	30*	60	90	120#
b. car park for light vehicles:						
i open sided car park <sup>(3)</sup>	Not applicable	Not applicable	15*+	15*+ <sup>(4)</sup>	15*+ <sup>(4)</sup>	60
ii. any other car park	90	60	30*	60*	90*	120#

Single storey buildings are subject to the periods under the heading “not more than 5”. If they have basements, the basement storeys are subject to the period appropriate to their depth.

§ The floor over a basement (or if there is more than 1 basement, the floor over the topmost basement) should meet the provisions for the ground and upper storeys if that period is higher.

\* Increased to a minimum of 60 minutes for compartment walls separating buildings.



## Appendix A

- \*\* Reduced to 30 minutes for any floor within a flat with more than one storey, but not if the floor contributes to the support of the building.
- # Reduced to 90 minutes for elements not forming part of the structural frame.
- + Increased to 30 minutes for elements protecting the means of escape.
- † Refer to paragraph 8.9 regarding the acceptability of 30 minutes in flat conversions.

### Notes:

- 1 Refer to Table A1 for the specific provisions of test.
- 2 “Sprinklered” means that the building is fitted throughout with an automatic fire suppression system in accordance with Section 2.
3. The car park should comply with the relevant provisions in the guidance on requirement B3, Section 12.
4. For the purposes of meeting the Building Regulations, the following types of steel elements are deemed to have satisfied the minimum period of fire resistance of 15 minutes when tested to the European test method;
  - i. Beams supporting concrete floors maximum  $H_p/A=230m^{-1}$  operating under full design load.
  - ii. Free standing columns, maximum  $H_p/A=180m^{-1}$  operating under full design load.
  - iii. Wind bracing and struts, maximum  $H_p/A\sim 210m^{-1}$  operating under full design load.

Guidance is also available in BS 5950 Structural use of steelwork in building. Part 8 Code of practice for fire resistant design.

---

## Appendix A

### Application of the fire resistance standards in Table A2:

- a. Where one element of structure supports or carries or gives stability to another, the fire resistance of the supporting element should be no less than the minimum period of fire resistance for the other element (whether that other element is loadbearing or not).

There are circumstances where it may be reasonable to vary this principle, for example:

- i. where the supporting structure is in the open air and is not likely to be affected by the fire in the building; or
  - ii. the supporting structure is in a different compartment, with a fire-separating element (which has the higher standard of fire resistance) between the supporting and the separated structure; or
  - iii. where a plant room on the roof needs a higher fire resistance than the elements of structure supporting it.
- b. Where an element of structure forms part of more than one building or compartment, that element should be constructed to the standard of the greater of the relevant provisions.
  - c. Where one side of a basement is (due to the slope of the ground) open at ground level, giving an opportunity for smoke venting and access for fire fighting, it may be appropriate to adopt the standard of fire resistance applicable to above-ground structures for elements of structure in that storey.
  - d. Although most elements of structure in a single storey building may not need fire resistance (see the guidance on requirement B3, paragraph 8.4(a)), fire resistance will be needed if the element:
    - i. is part of (or supports) an external wall and there is provision in the guidance on requirement B4 to limit the extent of openings and other unprotected areas in the wall; or
    - ii. is part of (or supports) a compartment wall, including a wall common to two or more buildings; or
    - iii. supports a gallery.

For the purposes of this paragraph, the ground storey of a building which has one or more basement storeys and no upper storeys, may be considered as a single storey building. The fire resistance of the basement storeys should be that appropriate to basements.

Appendix A

Table A3 Limitations on fire-protecting suspended ceilings see Table A1, Note 4			
Height of building or separated part (m)	Type of floor	Provision for fire resistance or floor (minutes)	Type of floor
Less than 18	Not compartment	60 or less	Type W, X, Y or Z
	Compartment	Less than 60	
		60	Type X, Y or Z
18 or more	any	60 or less	Type Y or Z
No limit	any	More than 60	Type Z

**Notes:**

1. Ceiling type and description (the change from Types A-D to Types W-Z is to avoid confusion with Classes A-D (European)):

W. Surface of ceiling exposed to the cavity should be Class 0 or Class 1 (National) or Class C-s3, d2 or better (European).

X. Surface of ceiling exposed to the cavity should be Class 0 (National) or Class B-s3, d2 or better (European).

Y. Surface of ceiling exposed to the cavity should be Class 0 (National) or Class B-s3, d2 or better (European). Ceiling should not contain easily openable access panels.

Z. Ceiling should be of a material of limited combustibility (National) or of Class A2-s3, d2 or better (European) and not contain easily openable access panels. Any insulation above the ceiling should be of a material of limited combustibility (National) or Class A2-s3, d2 or better (European).

2. Any access panels provided in fire protecting suspended ceilings of type Y or Z should be secured in position by releasing devices or screw fixings, and they should be shown to have been tested in the ceiling assembly in which they are incorporated.

3. The National classifications do not automatically equate with the equivalent European classifications, therefore, products cannot typically assume a European class unless they have been tested accordingly.

When a classification includes 's3, d2', this means that there is no limit set for smoke production and/or flaming droplets/particles.

Appendix A

<b>Table A4 Limitations on the use of uninsulated glazed elements on escape routes (These limitations do not apply to glazed elements which satisfy the relevant insulation criterion, see Table A1)</b>				
<b>Position of glazed element</b>	<b>Maximum total glazed area in parts of a building with access to:</b>			
	<b>A single stairway</b>		<b>More than one stairway</b>	
	<b>Walls</b>	<b>Door leaf</b>	<b>Walls</b>	<b>Door leaf</b>
<b>Flats</b> 1. Within the enclosures of a protected entrance hall or protected landing or within fire-resisting separation shown in Section 3 Diagram 4.	Fixed Fanlights only	Unlimited above 1100mm from floor	Fixed fanlights only	Unlimited above 1100mm from floor
<b>General</b> 2. Between residential/sleeping accommodation and a common escape route (corridor, lobby or stair).	Nil	Nil	Nil	Nil
3. Between a protected stairway <sup>(1)</sup> and a. the accommodation; or ba corridor which is not a protected corridor. Other than in item 2 above.	Nil	25% of door area	Unlimited above 1100mm <sup>(2)</sup>	50% of door area
4. Between a. a protected stairway <sup>(1)</sup> and a protected lobby or protected corridor, or b. accommodation and a protected lobby. Other than in item 2 above	Unlimited above 1100mm from floor	Unlimited above 100mm from floor	Unlimited above 100mm from floor	Unlimited above 100mm from floor
5. Between the accommodation and a protected corridor forming a dead end. Other than in item 2 above.	Unlimited above 1100mm from floor	Unlimited above 100mm from floor	Unlimited above 100mm from floor	Unlimited above 100mm from floor
6. Between accommodation and any other corridor; or subdividing corridors. Other than in item 2 above	Not applicable	Not applicable	Unlimited above 100mm from floor	Unlimited above 100mm from floor
7. Adjacent an external escape route described in para 4.30.	Unlimited above 1100mm from floor	Unlimited above 1100mm from floor	Unlimited above 1100mm from floor	Unlimited above 1100mm from floor
8. Adjacent an external escape stair (see para 6.25 and diagram 25) of roof escape (see para 6.35).	Unlimited	Unlimited	Unlimited	Unlimited

**Notes:**

1. If the protected stairway is also a protected shaft (see paragraph 9.35) or a firefighting stair (see Section 18) there may be further restrictions on the uses of glazed elements.
2. Measured vertically from the landing floor level or the stair pitch line.
3. The 100mm limit is intended to reduce the risk of fire spread from a floor covering.
4. Items 1 and 4 apply also to single storey buildings.
5. Fire-resisting glass should be marked with the manufacturer and product name.
6. Further guidance can be found in A guide to best practice in the specification and use of fire-resistant glazed systems published by the Glass and Glazing Federation.

Appendix A

Table A5 Notional designations of roof coverings			
<b>Part i: Pitched roofs covered with slates or tiles</b>			
Covering material	Supporting structure	Designation	
1. Natural slates 2. Fibre reinforced cement slates 3. Clay tiles 4. Concrete tiles	Timber rafters with or without underfelt, sarking, boarding, woodwool slabs, compressed straw slabs, plywood, wood chipboard, or fibre insulating board	AA (National class) or B <sub>ROOF(t4)</sub> (European class)	
<p><b>Note:</b> Although the Table does not include guidance for roofs covered with bitumen felt, it should be noted that there is a wide range of materials on the market and information on specific products is readily available from manufacturers.</p>			
<b>Part ii: Pitched roofs covered with self-supporting sheet</b>			
Roof covering material	Construction	Supporting structure	Designation
1. Profiled sheet of galvanised steel, aluminium, fibre reinforced cement, or pre-painted (coil coated) steel or aluminium with a pvc or pvf2 coating	Single skin without underlay, or with underlay or plasterboard, fibre insulating board, or woodwool slab	Structure of timber, steel or concrete	AA (National class) or B <sub>ROOF(t4)</sub> (European class)
2. Profiled sheet of galvanised steel, aluminium, fibre reinforced cement, or pre-painted (coil coated) steel or aluminium with a pvc or pvf2 coating	Double skin without interlayer, or with interlayer of resin bonded glass fibre, mineral wool slab, polystyrene, or polyurethane	Structure of timber, steel or concrete	AA (National class) or B <sub>ROOF(t4)</sub> (European class)
<b>Part iii. Flat roofs covered with bitumen felt</b>			
<p>A flat roof comprising bitumen felt should (irrespective of the felt specification) be deemed to be of designation AA (National class) or B<sub>ROOF(t4)</sub> (European class) if the felt is laid on a deck constructed of 6mm plywood, 12.5mm wood chipboard, 16mm (finished) plain edged timber boarding, compressed straw slab, screeded wood wool slab, profiled fibre reinforced cement or steel deck (single or double skin) with or without fibre insulating board overlay, profiled aluminium deck (single or double skin) with or without fibre insulating board overlay, or concrete or clay pot slab (insitu or pre cast), and has a surface finish of:</p> <ol style="list-style-type: none"> <li>bitumen-bedded stone chippings covering the whole surface to a depth of at least 12.5mm;</li> <li>bitumen-bedded tiles of a non-combustible material;</li> <li>sand and cement screed; or</li> <li>macadam.</li> </ol>			

Appendix A

Table A5 Notional designations of roof coverings (continued)		
Part iv. Pitched or flat roofs covered with fully supported material		
Covering material	Supporting structure	Designation
1. Aluminium sheet 2. Copper sheet 3. Zinc sheet 4. Lead sheet 5. Mastic asphalt	timber joists and: tongued and grooved boarding, or plain edged boarding	AA* (National class) or B <sub>ROOF(t4)</sub> (European class)
6. Vitreous enamelled steel 7. Lead/tin alloy coated steel sheet 8. Zinc/aluminium alloy coated steel sheet	steel or timber joists with deck of: woodwool slabs, compressed straw slab, wood chipboard, fibre insulating board, or 9.5mm plywood	AA (National class) or B <sub>ROOF(t4)</sub> (European class)
9. Pre-painted (coil coated) steel sheet including liquid-applied pvc coatings	non-combustible deck of steel, aluminium, or fibre cement (with or without insulation)	AA (National class) or B <sub>ROOF(t4)</sub> (European class)
<p><b>Notes:</b></p> <p>* Lead sheet supported by timber joists and plain edged boarding should be regarded as having a BA designation and is deemed to be designated class C<sub>ROOF(t4)</sub> (European class).</p> <p>The National classifications do not automatically equate with the equivalent classifications in the European column, therefore products cannot typically assume a European class unless they have been tested accordingly.</p>		

Appendix A

**Table A6 Use and definitions of non-combustible materials**

References in AD B guidance to situations where such materials should be used	Definitions of non-combustible materials	
	National class	European class
<p>1. refuse chutes meeting the provisions in the guidance to B3, paragraph 9.34c</p> <p>2. suspended ceilings and their supports where there is provision in the guidance to B3, paragraph 10.12, for them to be constructed of non-combustible materials.</p> <p>3. pipes meeting the provisions in the guidance to B3. Table 14.</p> <p>4. flue walls meeting the provisions in the guidance to B3, Diagram 39.</p> <p>5. construction forming car parks referred to in the guidance to B3, paragraph 12.3.</p>	<p>a. Any material which when tested to BS 476-11:1982 does not flame nor cause any rise in temperature on either the centre (specimen) or furnace thermocouples.</p> <p>b. Totally inorganic materials such as concrete, fired clay, ceramics, metals, plaster and masonry containing not more than 1% by weight or volume of organic material. (Use in buildings of combustible metals such as magnesium/aluminium alloys should be assessed in each individual case).</p> <p>c. Concrete bricks or blocks meeting BS EN 771-3:2003</p> <p>d. Products classified as non-combustible under BS 476-4:1970</p>	<p>a. Any material classified as class A1 in accordance with BS EN 13501-1:2018 <i>Fire classification of construction products and building elements. Classification using data from reaction to fire tests.</i></p> <p>b. Products made from one or more of the materials considered as Class A1 without the need for testing as defined in Commission Decision 2003/424/EC of 6th June 2003 amending Decision ,96/603/EC establishing the list of products belonging to Classes A1 “No contribution to fire” provided for in the Decision 94/611/EC implementing Article 20 of the Council Directive ,89/106/EEC on construction products. None of the materials shall contain more than 1% by weight or volume (whichever is the more onerous) of homogeneously distributed organic material</p>
<p><b>Note:</b></p> <p>The National classifications do not automatically equate with the equivalent classifications in the European column, therefore products cannot typically assume a European class unless they have been tested accordingly.</p>		

Appendix A

**Table A7 Use and definitions of materials of limited combustibility**

References in AD B guidance to situations where such materials should be used	Definitions of materials of limited combustibility	
	National class	European class
<p>1. Stairs where there is provision in the guidance to B1 for them to be constructed of materials of limited combustibility (see 6.19)</p> <p>2. Materials above a suspended ceiling meeting the provisions in the guidance to B3, paragraph 10.12</p> <p>3. Reinforcement/support for fire-stopping referred to in the guidance to B3, see 11.18.</p> <p>4. Roof coverings meeting provisions:                      a. in the guidance to B3, paragraph 9.29 or                      b. in the guidance to B4. Table 16 or                      c. in the guidance to B4. Diagram 47</p> <p>5. Roof deck meeting the provisions of the guidance to B3, Diagram 30a</p> <p>6. Class O materials meeting the provisions in Appendix A, paragraph 16(a).</p> <p>7. Ceiling tiles or panels of any fire protecting suspended ceiling (Type Z) in Table A3.</p>	<p>a. Any non-combustible material listed in Table A6.</p> <p>b. Any material of density 300/kg/m<sup>3</sup> or more, which when tested to BS 476-11:1982, does not flame and the rise in temperature on the furnace thermocouple is not more than 20°C.</p> <p>c. Any material with a non-combustible core at least 8mm thick having combustible facings (on one or both sides) not more than 0.5mm thick (<b>Where</b> a flame spread rating is specified, these materials must also meet the appropriate test requirements).</p>	<p>a. Any material listed in Table A6.</p> <p>b. Any material/product classified as Class A2-s3, d2 or better in accordance with BS EN 13501-1:2018 <i>Fire classification of construction products and building elements. Part 1 - Classification using data from reaction to fire tests.</i></p>
<p>8. Insulation material in external wall construction referred to in paragraph 13.6.</p> <p>9. Insulation above any fire-protecting suspended ceiling (Type Z) in Table A3.</p>	<p>Any of the materials (a), (b) or (c) above, or:                      d. Any material of density less than 300kg/m<sup>3</sup>, which when tested to BS 476-11:1982, does not flame for more than 10 seconds and the rise in temperature on the centre (specimen) thermocouple is not more than 35°C and on the furnace thermocouple is not more than 25°C.</p>	<p>Any of the materials/products (a) or (b) above.</p>

**Note:**

1. The National classifications do not automatically equate with the equivalent classifications in the European column, therefore products cannot typically assume a European class unless they have been tested accordingly.
2. When a classification includes “s3, d2”, this means that there is no limit set for smoke production and/or flaming droplets/particles.



Appendix A

**Table A8 Typical performance ratings of some generic materials and products**

Rating	Material or product
Class 0 (National)	1. Any non-combustible material or material of limited combustibility. (composite products listed in Table A7 must meet test requirements given in Appendix A, paragraph 16(b)). 2. Brickwork, blockwork, concrete and ceramic tiles. 3. Plasterboard (painted or not with a PVC facing not more than 0.5mm thick) with or without an air gap or fibrous or cellular insulating material behind. 4. Woodwool cement slabs. 5. Mineral fibre tiles or sheets with cement or resin binding.
Class 3 (National)	6. Timber or plywood with a density more than 400kg/m <sup>3</sup> , painted or unpainted. 7. Wood particle board or hardboard, either untreated or painted. 8. Standard glass reinforced polyesters.
Class A1 (European)	9. Any material that achieves this class or is defined as 'classified without further test' in a published Commission Decision.
Class A2-s3, d2 (European)	10. Any material that achieves this class or is defined as 'classified without further test' in a published Commission Decision.
Class B-s3, d2 (European)	11. Any material that achieves this class or is defined as 'classified without further test' in a published Commission Decision.
Class C-s3, d2 (European)	12. Any material that achieves this class or is defined as 'classified without further test' in a published Commission Decision.
Class D-s3, d2 (European)	13. Any material that achieves this class or is defined as 'classified without further test' in a published Commission Decision.

**Notes (National):**

1. Materials and products listed under Class 0 also meet Class 1.
2. Timber products listed under Class 3 can be brought up to Class 1 with appropriate proprietary treatments.
3. The following materials and products may achieve the ratings listed below. However, as the properties of different products with the same generic description vary, the ratings of these materials/products should be substantiated by test evidence.

Class 0 – aluminium faced fibre insulating board, flame retardant decorative laminates on a calcium silicate board, thick polycarbonate sheet, phenolic sheet and UPVC.

Class 1 – phenolic or melamine laminates on a calcium silicate substrate and flame-retardant decorative laminates on a combustible substrate.

## Appendix A

### Notes (European):

For the purposes of the Building Regulations:

1. Materials and products listed under Class A1 also meet Classes A2-s3, d2, B-s3, d2, C-s3, d2 and D-s3, d2.
  2. Materials and products listed under Class A2-s3, d2 also meet Classes B-s3, d2, C-s3, d2 and D-s3, d2.
  3. Materials and products listed under Class B-s3, d2 also meet Classes C-s3, d2 and D-s3, d2.
  4. Materials and products listed under Class C-s3, d2 also meet Class D-s3, d2.
  5. The performance of timber products listed under Class D-s3, d2 can be improved with appropriate proprietary treatments.
  6. Materials covered by the CWFT process (classification without further testing) can be found by accessing the European Commission's website via the link on the CLG website [www.communities.gov.uk](http://www.communities.gov.uk)
  7. The national classifications do not automatically equate with the equivalent classifications in the European column, therefore products cannot typically assume a European class unless they have been tested accordingly.
  8. When a classification includes 's3, d2', this means that there is no limit set for smoke production and/or flaming droplets/particles.
-

## Appendix B

---

### Fire doors

1. All fire doors should have the appropriate performance given in Table B1 either:
  - a. by their performance under test to BS 476-22 *Fire tests on building materials and structures. Methods for determination of the fire resistance of non-loadbearing elements of construction*, in terms of integrity for a period of minutes, e.g. FD30. A suffix (S) is added for doors where restricted smoke leakage at ambient temperatures is needed; or
  - b. as determined with reference to Commission Decision 2000/367/EC of 3 May 2000 implementing Council Directive 89/106/EEC as regards the classification of the resistance to fire performance of construction products, construction works and parts thereof. All fire doors should be classified in accordance with BS EN 13501-2: 2003, *Fire classification of construction products and building elements. Classification using data from fire resistance tests (excluding products for use in ventilation systems)*. They are tested to the relevant European method from the following:
    - BS EN 1634-1:2008 *Fire resistance and smoke control tests for door and shutter assemblies, openable windows and elements of building hardware. Fire resistance tests for doors, shutters and openable windows*;
    - BS EN 1634-2: 2008 *Fire resistance and smoke control tests for door and shutter assemblies, openable windows and elements of building hardware. Fire resistance characterisation test for elements of building hardware*;
    - BS EN 1634-3:2004 *Fire resistance and smoke control tests for door and shutter assemblies, openable windows and elements of building hardware. Smoke control test for door and shutter assemblies*; or
  - c. as determined with reference to European Parliament and Council Directive 95/16/EC (applies to lifts permanently serving buildings and constructions and specified safety components) of 29th June 1995 on the approximation of laws of Member States relating to lifts ('Lifts Directive') implementing the Lifts Regulations 1997 (S.I. 1997/831) and calling upon the harmonised standard BS EN 81-58: 2003 *Safety rules for the construction and installation of lifts – Examination and tests. Landing doors fire resistance test*.

The performance requirement is in terms of integrity (E) for a period of minutes. An additional classification of Sa is used for all doors where restricted smoke leakage at ambient temperatures is needed.

The requirement (in either case) is for test exposure from each side of the door separately, except in the case of lift doors which are tested from the landing side only.

## Appendix B

Any test evidence used to substantiate the fire resistance rating of a door or shutter should be carefully checked to ensure that it adequately demonstrates compliance and is applicable to the **complete installed assembly**. Small differences in detail (such as glazing apertures, intumescent strips, door frames and ironmongery etc.) may significantly affect the rating.

**Note 1:** Both BS 476-22 and BS EN 1634-1 acknowledge that it may not always be necessary to carry out tests from both sides of a door set. Clause 13.4 of EN 1634-1 states when it may be appropriate to test on one side. Annex C of the guidance sets out the rationale for these rules and specifically excludes composite doors by stating that:

**“Door sets made from other (i.e. not wood or metal) or composite materials are specifically excluded from this annex as there is not sufficient evidence of their behaviour in fire to be able to provide guidance on the weakest side against fire attack.”**

Clause 13.4 of BS EN 1634-1 should therefore be followed when determining whether a test should be carried out from both sides of a door set regardless of whether it is being classified to BS 476-22 or BS EN 1634-1.

**Note 2:** The latest version of any standard may be used provided that it continues to address the relevant requirements of the Regulations.

**Note 3:** Until such time that the relevant harmonised product standards are published, for the purposes of meeting the Building Regulations, products tested in accordance with BS EN 1634-1 (with or without pre-fire test mechanical conditioning) will be deemed to have satisfied the provisions provided that they achieve the minimum fire resistance in terms of integrity, as detailed in Table B1.

2. All fire doors should be fitted with a self-closing device except for fire doors to cupboards and to service ducts which are normally kept locked shut and fire doors within flats (self-closing devices are still necessary on flat entrance doors).

**Note:** All rolling shutters should be capable of being opened and closed manually for firefighting purposes (see Section 18, paragraph 18.15).

3. Where a self-closing device would be considered a hindrance to the normal approved use of the building, self-closing fire doors may be held open by:
  - a. a fusible link (but not if the door is fitted in an opening provided as a means of escape unless it complies with paragraph 4 below); or
  - b. an automatic release mechanism actuated by an automatic fire detection and alarm system; or
  - c. a door closer delay device.
4. Two fire doors may be fitted in the same opening so that the total fire resistance is the sum of their individual fire resistances, provided that each door is capable of closing the opening. In such a case, if the opening is provided as a means of

## Appendix B

escape, both doors should be self-closing, but one of them may be fitted with an automatic self-closing device and be held open by a fusible link if the other door is capable of being easily opened by hand and has at least 30 minutes fire resistance.

5. Because fire doors often do not provide any significant insulation, there should be some limitation on the proportion of doorway openings in compartment walls. Therefore no more than 25% of the length of a compartment wall should consist of door openings, unless the doors provide both integrity and insulation to the appropriate level (see Appendix A, Table A2).

**Note:** Where it is practicable to maintain a clear space on both sides of the doorway, then the above percentage may be greater.

6. Roller shutters across a means of escape should only be released by a heat sensor, such as a fusible link or electric heat detector, in the immediate vicinity of the door. Closure of shutters in such locations should not be initiated by smoke detectors or a fire alarm system, unless the shutter is also intended to partially descend to form part of a boundary to a smoke reservoir.
7. Unless shown to be satisfactory when tested as part of a fire door assembly, the essential components of any hinge on which a fire door is hung should be made entirely from materials having a melting point of at least 800°C.
8. Except for doors identified in paragraph 9 below, all fire doors should be marked with the appropriate fire safety sign complying with BS 5499-5:2002 according to whether the door is:
  - a. to be kept closed when not in use (Fire door keep shut);
  - b. to be kept locked when not in use (Fire door keep locked shut); or
  - c. held open by an automatic release mechanism or free swing device (Automatic fire door keep clear).

Fire doors to cupboards and to service ducts should be marked on the outside; all other fire doors on both sides.

9. The following fire doors are not required to comply with paragraph 8 above:
  - a. doors to and within flats;
  - b. bedroom doors in 'Other-residential' premises; and
  - c. lift entrance/landing doors.
10. Tables A1 and A2 set out the minimum periods of fire resistance for the elements of structure to which performance of some doors is linked. Table A4 sets out limitations on the use of uninsulated glazing in fire doors.
11. BS 8214:1990 gives recommendations for the specification, design, construction, installation and maintenance of fire doors constructed with non-metallic door leaves.

## Appendix B

Guidance on timber fire-resisting doorsets, in relation to the new European test standard, may be found in *Timber Fire-Resisting Doorsets: maintaining performance under the new European test standard* published by TRADA.

Guidance for metal doors is given in *Code of practice for fire-resisting metal doorsets* published by the DSMA (Door and Shutter Manufacturers' Association) in 1999.

- 12.** Hardware used on fire doors can significantly affect performance in fire. Notwithstanding the guidance in this Approved Document, guidance is available in *Hardware for fire and escape doors* published by the Builders Hardware Industry Federation and Guild of Architectural Ironmongers.

Table B1 Provisions for fire doors		
Position of door	Minimum fire resistance of door in terms of integrity (minutes) when tested to BS 476-22 <sup>(1)</sup>	Minimum fire resistance of door in terms of integrity (minutes) when tested to the relevant European standard <sup>(3)</sup>
1. In a compartment wall separating buildings	As for the wall in which the door is fitted, but a minimum of 60	As for the wall in which the door is fitted, but a minimum of 60
2. In a compartment wall:		
a. If it separates a flat from a space in common use	FD 30S <sup>(2)</sup>	E30 S <sub>a</sub> <sup>(2)</sup>
b. Enclosing a protected shaft forming a stairway situated wholly or partly above the adjoining ground in a building used for Flats, Other Residential, Assembly and Recreation, or Office purposes;	FD 30S <sup>(2)</sup>	E30 S <sub>a</sub> <sup>(2)</sup>
c. enclosing a protected shaft forming a stairway not described in (b) above;	Half the period of fire resistance of the wall in which it is fitted, but 30 minimum and with suffix S <sup>(2)</sup>	Half the period of fire resistance of the wall in which it is fitted, but 30 minimum and with suffix S <sub>a</sub> <sup>(2)</sup>
d. enclosing a protected shaft forming a lift or service shaft;	Half the period of fire resistance of the wall in which it is fitted, but 30 minimum	Half the period of fire resistance of the wall in which it is fitted, but 30 minimum
e. not described in (a), (b), (c) or (d) above	As for the wall it is fitted in, but add S <sub>a</sub> <sup>(2)</sup> if the door is used for progressive horizontal evacuation under the guidance to B1	As for the wall it is fitted in, but add S <sub>a</sub> <sup>(2)</sup> if the door is used for progressive horizontal evacuation under the guidance to B1

<b>3. In a compartment floor</b>	As for the floor in which it is fitted	As for the floor in which it is fitted
<b>4. Forming part of the enclosures of:</b>  a. a protected stairway (except as described in item 9) ; or  b. a lift shaft (see paragraph 6.42b); which does not form a protected shaft in 2(b), (c) or (d) above.	FD 30S <sup>(2)</sup>  FD 30	E30 S <sub>a</sub> <sup>(2)</sup>  E30
<b>5. Forming part of the enclosure of:</b>  a. a protected lobby approach (or protected corridor) to a stairway;  b. any other protected corridor; or  c. a protected lobby approach to a lift shaft (see paragraph 6.42)	FD 30S <sup>(2)</sup>  FD 20S <sup>(2)</sup>  FD 30S <sup>(2)</sup>	E30 S <sub>a</sub> <sup>(2)</sup>  E20 S <sub>a</sub> <sup>(2)</sup>  E30 S <sub>a</sub> <sup>(2)</sup>

## Appendix B

<b>Table B1 Provisions for fire doors (continued)</b>		
<b>Position of door</b>	<b>Minimum fire resistance of door in terms of integrity (minutes) when tested to BS 476-22 (1)</b>	<b>Minimum fire resistance of door in terms of integrity (minutes) when tested to the relevant European standard (3)</b>
<b>6. Affording access to an external escape route</b>	FD 30	E30
<b>7. Sub-dividing:</b> a. corridors connecting alternative exits b. dead-end portions of corridors from the remainder of the corridor	FD 20S <sup>(2)</sup> FD 20S <sup>(2)</sup>	E20 S <sub>a</sub> <sup>(2)</sup> E20 S <sub>a</sub> <sup>(2)</sup>
<b>8. Any door within a cavity barrier</b>	FD 30	E 30
<b>9. Any door forming part of the enclosure to a protected entrance hall or protected landing in a flat;</b>	FD 20	E20
<b>10. Any door forming part of the enclosure</b> a. to a place of special fire risk b. to ancillary accommodation in care homes (see paragraph 4.50)	FD30 FD30	E30 E30

### Notes

1. To BS 476-22:1987 (or BS 476-8:1972 subject to paragraph 8 in Appendix A).
2. Unless pressurization techniques complying with BS EN 12101-6:2005 Code of practice for smoke control using pressure differentials are used, these doors should also either:
  - a. have a leakage rate not exceeding 3m<sup>3</sup>/m/hour (head and jambs only) when tested at 25 Pa under BS 476 *Fire tests on building materials and structures*, Section 31.1 *Methods for measuring smoke penetration through doorsets and shutter assemblies, Method of measurement under ambient temperature conditions*; or
  - b. meet the additional classification requirement of S<sub>a</sub> when tested to BS EN 1634-3:2001 *Fire resistance tests for door and shutter assemblies*, Part 3 – *Smoke control doors*.
3. The National classifications do not automatically equate with the equivalent classifications in the European column, therefore products cannot typically assume a European class unless they have been tested accordingly.



# Appendix C

## Methods of measurement

1. Some form of measurement is an integral part of many of the provisions in this document. Paragraphs 2 to 5 and Diagrams C1 to C7 show how the various forms of measurement should be made.

### Occupant capacity

2. The **occupant capacity** of a room, storey, building or part of a building is:
  - a. the maximum number of persons it is designed to hold;
  - b. the number calculated by dividing the area of room or storey(s) (m<sup>2</sup>) by a floor space factor (m<sup>2</sup> per person) such as those given in Table C1 for guidance.

**Note:** 'area' excludes stair enclosures, lifts, sanitary accommodation and any other fixed part of the building structure (but counters and display units, etc. should not be excluded).

**Table C1 Floor space factors <sup>(1)</sup>**

Type of accommodation <sup>(2)(3)</sup>	Floor space factor m <sup>2</sup> /person
1. Standing spectator areas, bar areas (within 2m of serving point) similar refreshment areas	0.3
2. Amusement arcade, assembly hall (including a general purpose place of assembly), bingo hall, club, crush hall, dance floor or hall, venue for pop concert and similar events and bar areas without fixed seating	0.5
3. Concourse, queuing area or shopping mall <sup>(4)(5)</sup>	0.7
4. Committee room, common room, conference room, dining room, licensed betting office (public area), lounge or bar (other than in 1 above), meeting room, reading room, restaurant, staff room or waiting room <sup>(6)</sup>	1.0
5. Exhibition hall or studio (film, radio, television, recording)	1.5
6. Skating rink	2.0
7. Shop sales area <sup>(7)</sup>	2.0
8. Art gallery, dormitory, factory production area, museum or workshop	5.0
9. Office	6.0
10. Shop sales area <sup>(8)</sup>	7.0
11. Kitchen or library	7.0
12. Bedroom or study-bedroom	8.0
13. Bed-sitting room, billiards or snooker room or hall	10.0
14. Storage and warehousing	30.0
15. Car park	Two persons per parking space

## Appendix C

### Notes:

1. As an alternative to using the values in the table, the floor space factor may be determined by reference to actual data taken from similar premises. Where appropriate, the data should reflect the average occupant density at a peak trading time of year.
2. Where accommodation is not directly covered by the descriptions given, a reasonable value based on a similar use may be selected.
3. Where any part of the building is to be used for more than one type of accommodation, the most onerous factor(s) should be applied. Where the building contains different types of accommodation, the occupancy of each different area should be calculated using the relevant space factor.
4. Refer to section 5 of BS 5588-10:1991 Code of practice for shopping complexes for detailed guidance on the calculation of occupancy in common public areas in shopping complexes.
5. For detailed guidance on appropriate floor space factors for concourses in sports grounds refer to “*Concourses*” published by the Football Licensing Authority (ISBN: 0 95462 932 9).
6. Alternatively the occupant capacity may be taken as the number of fixed seats provided, if the occupants will normally be seated.
7. Shops excluding those under item 10, but including - supermarkets and department stores (main sales areas), shops for personal services such as hairdressing and shops for the delivery or collection of goods for cleaning, repair or other treatment or for members of the public themselves carrying out such cleaning, repair or other treatment.
8. Shops (excluding those in covered shopping complexes but including department stores) trading predominantly in furniture, floor coverings, cycles, prams, large domestic appliances or other bulky goods, or trading on a wholesale self-selection basis (cash and carry).

## Travel distance

3. Travel distance is measured by way of the shortest route which if:
  - a. there is fixed seating or other fixed obstructions, is along the centre line of the seatways and gangways;
  - b. it includes a stair, is along the pitch line on the centre line of travel.

## Width

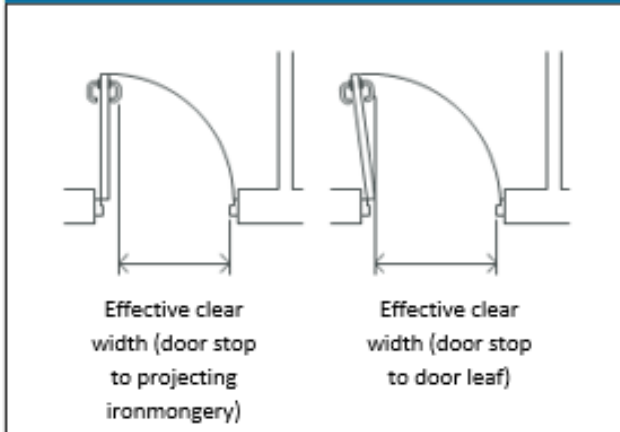
4. The width of:
  - a. a **door (or doorway)** is the clear width when the door is open (see Diagram C1);
  - b. an **escape route** is the width at 1500mm above floor level when defined by walls or, elsewhere, the minimum width of passage available between any fixed obstructions;
  - c. a **stair** is the clear width between the walls or balustrades.

**Note 1:** In the case of escape routes and stairs, handrails and strings which do not intrude more than 100mm into these widths may be ignored (see Diagram C1).

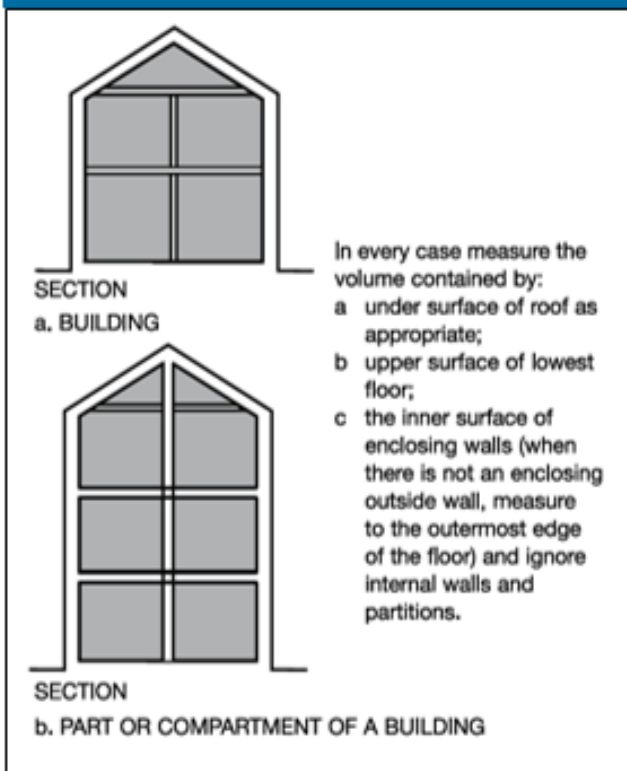
**Note 2:** The rails used for guiding a stair-lift may be ignored when considering the width of a stair. However, it is important that the chair or carriage is able to be parked in a position that does not cause an obstruction to either the stair or landing.

Appendix C

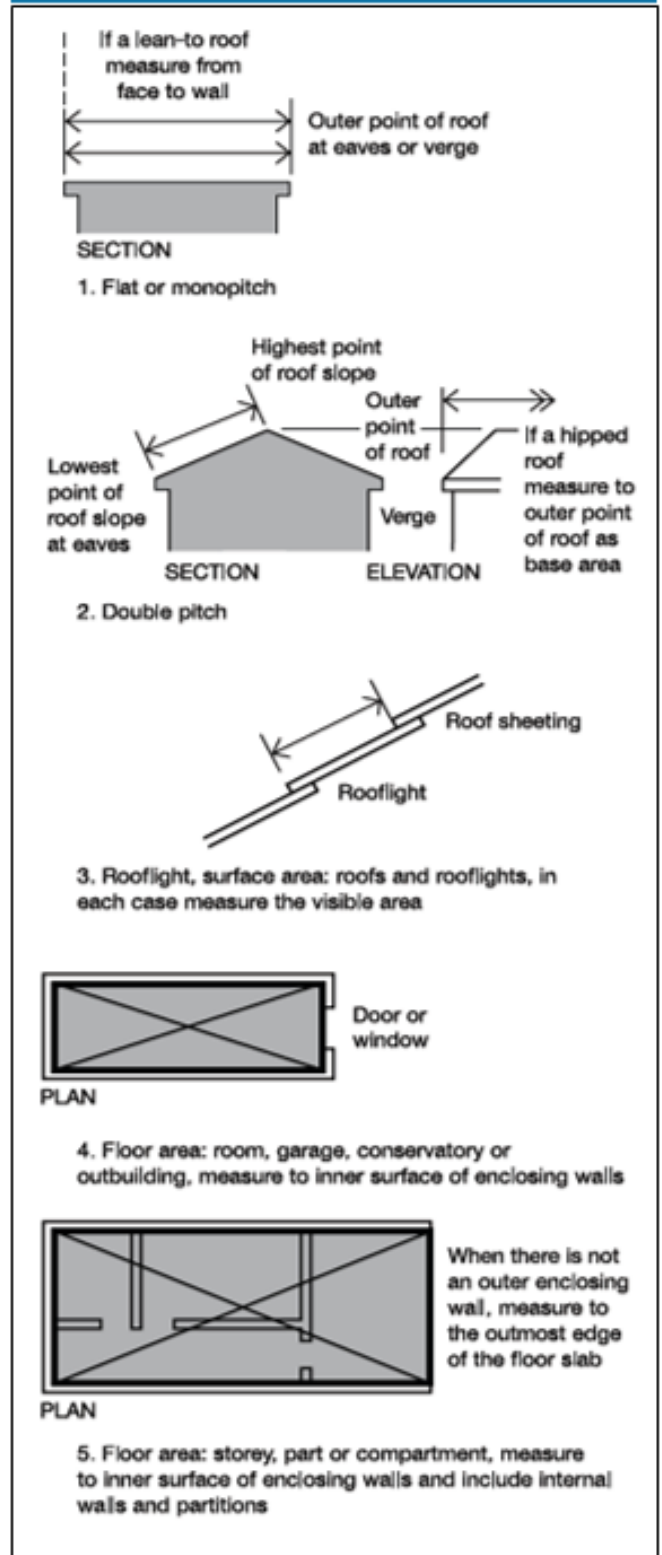
**Diagram C1 Measurement of door width**



**Diagram C2 Cubic capacity**

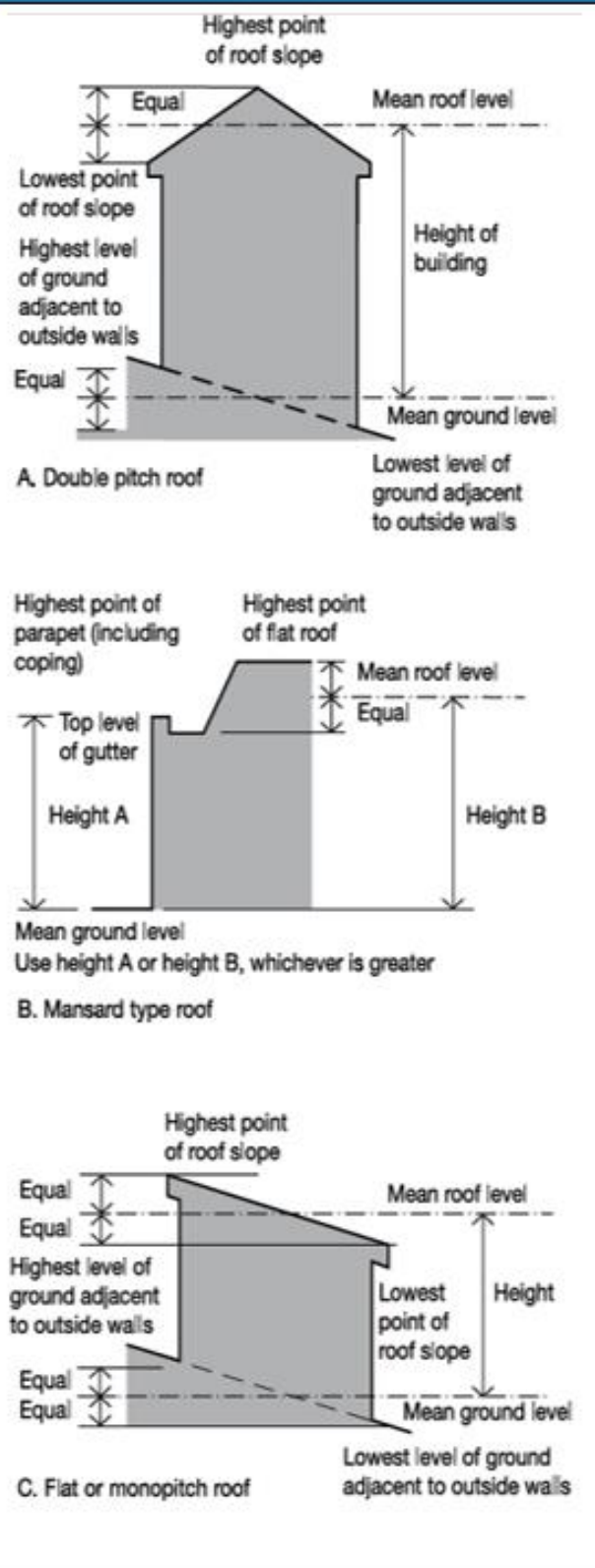


**Diagram C3 Area**



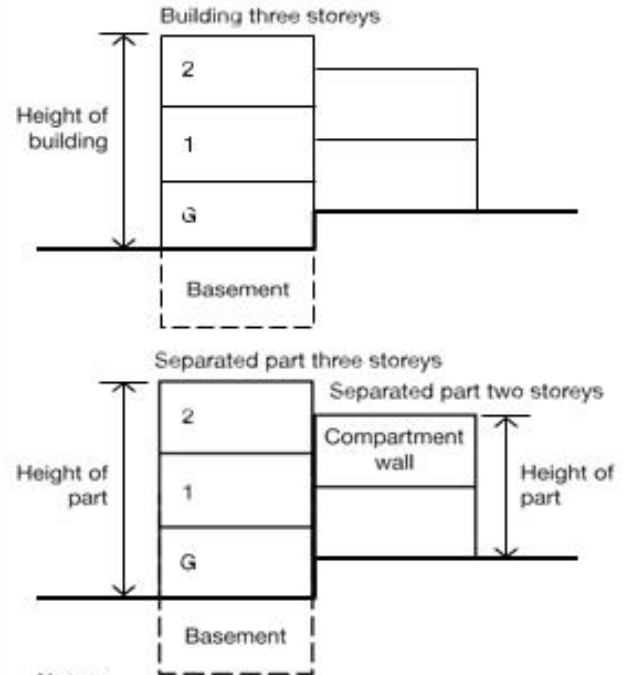
Appendix C

**Diagram C4 Height of building**



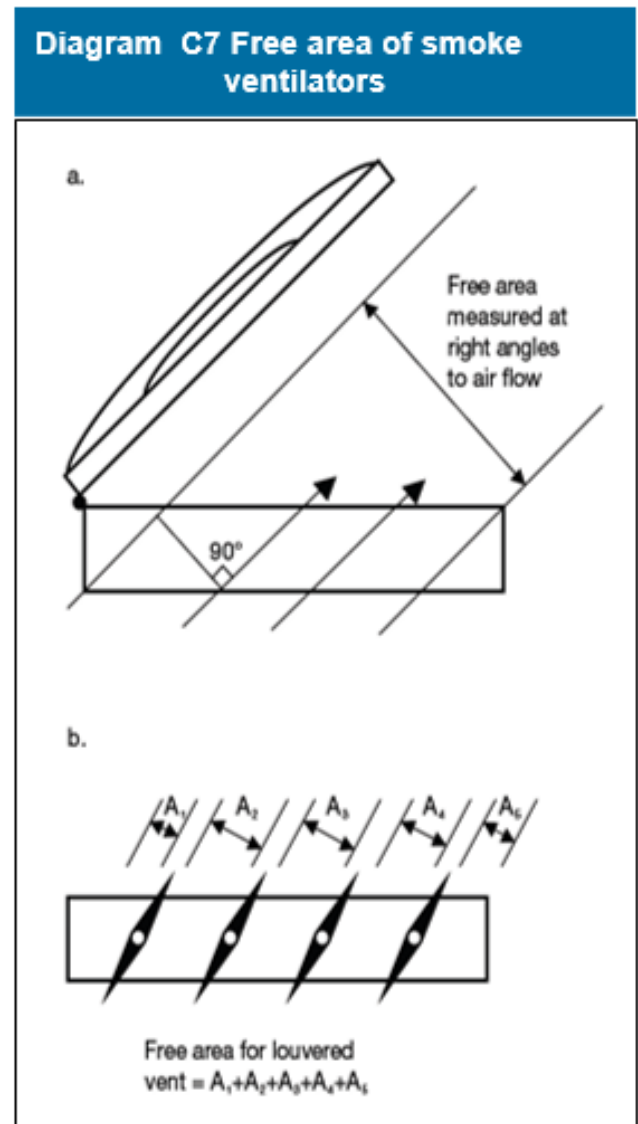
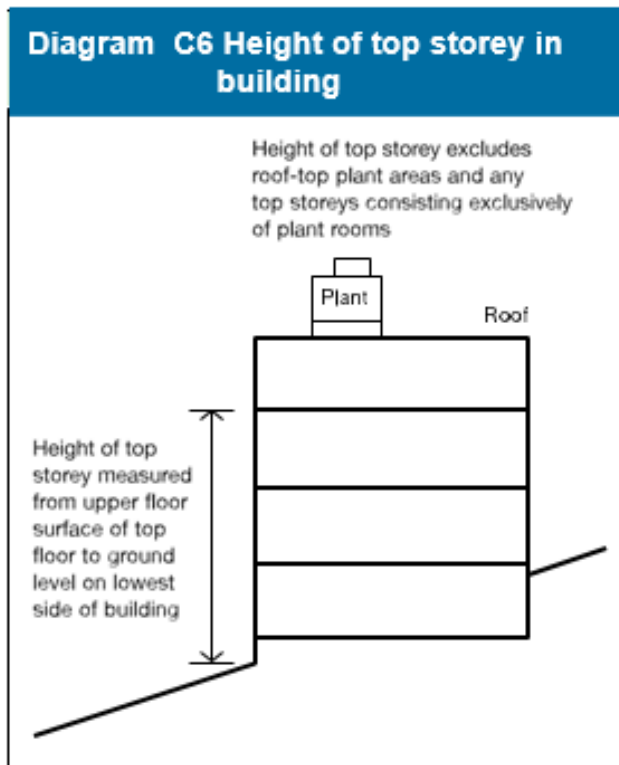
**Diagram C5 Number of storeys**

To count the number of storeys in a building, or in a separated part of a building, count only at the position which gives the greatest number and exclude any basement storeys.



**Notes:**  
 In assembly buildings, a gallery is included as a storey, but not if it is a loading gallery, fly gallery, stage grid, lighting bridge, or any gallery provided for similar purposes, or for maintenance and repair.  
 In other purpose group buildings, galleries are not counted as a storey.

Appendix C



## Free Area of Smoke Ventilators

5. The free area of a smoke ventilator, specified in this Approved Document, may be measured by either:
  - a. the declared aerodynamic free area in accordance with BS EN 12101-2:2003 *Smoke and heat control systems. Specification for natural smoke and heat exhaust ventilators*; or,
  - b. The total unobstructed cross sectional area, measured in the plane where the area is at a minimum and at right angles to the direction of air flow (see diagram C7).

## Appendix D

---

### Purpose groups

1. Many of the provisions in this document are related to the use of the building. The use classifications are termed purpose groups and represent different levels of hazard. They can apply to a whole building, or (where a building is compartmented) to a compartment in the building and the relevant purpose group should be taken from the main use of the building or compartment.
2. Table D1 sets out the purpose group classification.

**Note:** This is only of relevance to this Approved Document.

### Ancillary and main uses

3. In some situations there may be more than one use involved in a building or compartment and in certain circumstances it is appropriate to treat the different use as belonging to a purpose group in its own right. These situations are:
  - a. where the ancillary use is a flat; or
  - b. where the building or compartment is more than 280m<sup>2</sup> in area and the ancillary use is of an area that is more than a fifth of the total floor area of the building or compartment; or
  - c. storage in a building or compartment of Purpose Group 4 (shop or commercial), where the storage amounts to more than 1/3rd of the total floor area of the building or compartment and the building or compartment is more than 280m<sup>2</sup> in area.
4. Some buildings may have two or more main uses that are not ancillary to one another. For example offices over shops from which they are independent. In such cases, each of the uses should be considered as belonging to a purpose group in its own right.
5. In other cases and particularly in some large buildings, there may be a complex mix of uses. In such cases it is necessary to consider the possible risk that one part of a complex may have on another and special measures to reduce the risk may be necessary.

**Table D1: Classification of Purpose Groups**

Title	Group	Purpose for which the building or compartment of a building is intended to be used
Residential (dwellings)	1(a)*	Flat
	1(b)†	Dwellinghouse which contains a habitable storey with a floor level which is more than 4.5m above ground level.
	1(c)†+	Dwellinghouse which does not contain a habitable storey with a floor level which is more than 4.5m above ground level.
Residential (Institutional)  (Other)	2(a)	Hospital, home, school or other similar establishment used as living accommodation for, or for the treatment, care or maintenance of persons suffering from disabilities due to illness or old age or other physical or mental incapacity, or under the age of 5 years, or place of lawful detention, where such persons sleep on the premises.
	2(b)	Hotel, boarding house, residential college, hall of residence, hostel and any other residential purpose not described above.
Office	3	Offices or premises used for the purpose of administration, clerical work (including writing, book keeping, sorting papers, filing, typing, duplicating, machine calculating, drawing and the editorial preparation of matter for publication, police and fire and rescue service work), handling money (including banking and building society work), and communications (including postal, telegraph and radio communications) or radio, television, film, audio or video recording, or performance (not open to the public) and their control. or (except in the case of repair of motor vehicles) where they themselves may carry out such repairs or other treatments.
Shop and commercial	4	Shops or premises used for a retail trade or business (including the sale to members of the public of food or drink for immediate consumption and retail by auction, self-selection and over-the-counter wholesale trading, the business of lending books or periodicals for gain and the business of a barber or hairdresser and the rental of storage space to the public) and premises to which the public is invited to deliver or collect goods in connection with their hire repair or other treatment, or (except in the case of repair of motor vehicles) where they themselves may carry out such repairs or other treatments.
Assembly and recreation	5	Place of assembly, entertainment or recreation; including bingo halls, broadcasting, recording and film studios open to the public, casinos, dance halls; entertainment, conference, exhibition and leisure centres; funfairs and amusement arcades; museums and art galleries; non-residential clubs, theatres, cinemas and concert halls; educational establishments, dancing schools, gymnasia, swimming pool buildings, riding schools, skating rinks, sports pavilions, sports stadia; law courts; churches and other buildings of worship, crematoria; libraries open to the public, non-residential day centres, clinics, health centres and surgeries; passenger stations and termini for air, rail, road or sea travel; public toilets; zoos and menageries.

Appendix D

<b>Table D1: Classification of Purpose Groups (continued)</b>		
<b>Title</b>	<b>Group</b>	<b>Purpose for which the building or compartment of a building is intended to be used <sup>(3)</sup></b>
Industrial	6	Factories and other premises used for manufacturing, altering, repairing, cleaning, washing, breaking-up, adapting or processing any article; generating power or slaughtering livestock.
Storage and other non-residential <sup>+</sup>	7(a)	Place for the storage or deposit of goods or materials (other than described under 7(b)) and any building not within any of the Purpose Groups 1 to 6
	7(b)	Car parks designed to admit and accommodate only cars, motorcycles and passenger or light goods vehicles weighing no more than 2500kg gross.

**Notes:**

This table only applies to Part B.

- \* Includes live/work units that meet the provisions of paragraph 3.52.
- † includes any surgeries, consulting rooms, offices or other accommodation, not exceeding 50m<sup>2</sup> in total, forming part of a dwellinghouse and used by an occupant of the dwellinghouse in a professional or business capacity.
- + A detached garage not more than 40m<sup>2</sup> in area is included in purpose group 1(c); as is a detached open carport of not more than 40m<sup>2</sup>, or a detached building which consists of a garage and open carport where neither the garage nor the open carport exceeds 40m<sup>2</sup> in area.



## Appendix E

---

### Definitions

**Note:** Except for the items marked\* (which are from the Building Regulations), these definitions apply only to Part B.

**Access room** A room through which passes the only escape route from an inner room.

**Accommodation stair** A stair, additional to that or those required for escape purposes, provided for the convenience of occupants.

**Alternative escape routes** Escape routes sufficiently separated by either direction and space, or by fire-resisting construction, to ensure that one is still available should the other be affected by fire.

**Alternative exit** One of two or more exits, each of which is separate from the other.

**Appliance ventilation duct** A duct provided to convey combustion air to a gas appliance.

**Atrium (plural atria)** A space within a building, not necessarily vertically aligned, passing through one or more structural floors.

**Note:** Enclosed lift wells, enclosed escalator wells, building services' ducts and stairways are not classified as atria.

**Automatic fire suppression System** For the purposes of section 2 this refers to a system designed and installed in accordance with an appropriate, fully implemented, technical standard such as BS 9251: 2014, BSEN12845: 2009 or equivalent.

**Automatic release mechanism** A device which will allow a door held open by it to close automatically in the event of each or any one of the following:

- a. detection of smoke by automatic apparatus suitable in nature, quality and location;
- b. operation of a hand-operated switch fitted in a suitable position;
- c. failure of electricity supply to the device, apparatus or switch;
- d. operation of the fire alarm system if any.

**Basement storey** A storey with a floor which at some point is more than 1200mm below the highest level of ground adjacent to the outside walls. (However, see Appendix A, Table A2, for situations where the storey is considered to be a basement only because of a sloping site.)

**Boundary** The boundary of the land belonging to the building, or, where the land abuts a road, railway, canal or river, the centreline of that road, railway, canal or river. (See Diagram 41.)

## Appendix E

**\*Building** Any permanent or temporary building but not any other kind of structure or erection. A reference to a building includes a reference to part of a building.

**Building Control Body** A term used to include both Local Authority Building Control and Approved Inspectors.

**Cavity barrier** A construction, other than a smoke curtain, provided to close a concealed space against penetration of smoke or flame, or provided to restrict the movement of smoke or flame within such a space.

**Ceiling** A part of a building which encloses and is exposed overhead in a room, protected shaft or circulation space. (The soffit of a rooflight is included as part of the surface of the ceiling, but not the frame. An upstand below a rooflight would be considered as a wall).

**Circulation space** A space (including a protected stairway) mainly used as a means of access between a room and an exit from the building or compartment.

**Class 0** A product performance classification for wall and ceiling linings. The relevant test criteria are set out in Appendix A, paragraph 16.

**Common balcony** A walkway, open to the air on one or more sides, forming part of the escape route from more than one flat.

**Common stair** An escape stair serving more than one flat.

**Compartment (fire)** A building or part of a building, comprising one or more rooms, spaces or storeys, constructed to prevent the spread of fire to or from another part of the same building, or an adjoining building. (A roof space above the top storey of a compartment is included in that compartment.) (See also “Separated part”.)

**Compartment wall or floor** A fire-resisting wall/floor used in the separation of one fire compartment from another. (Constructional provisions are given in Section 9).

**Concealed space or cavity** A space enclosed by elements of a building (including a suspended ceiling) or contained within an element, but not a room, cupboard, circulation space, protected shaft or space within a flue, chute, duct, pipe or conduit.

**Corridor access** A design of a building containing flats in which each flat is approached via a common horizontal internal access or circulation space which may include a common entrance hall.

**Dead end** Area from which escape is possible in one direction only.

**Direct distance** The shortest distance from any point within the floor area, measured within the external enclosures of the building, to the nearest storey exit ignoring walls, partitions and fittings, other than the enclosing walls/partitions to protected stairways.

## Appendix E

**Dwelling** A unit of residential accommodation occupied (whether or not as a sole or main residence):

- a. by a single person or by people living together as a family; or
- b. by not more than 6 residents living together as a single household, including a household where care is provided for residents.

### **Element of structure**

- a. a member forming part of the structural frame of a building or any other beam or column;
- b. a loadbearing wall or loadbearing part of a wall;
- c. a floor;
- d. a gallery (but not a loading gallery, fly gallery, stage grid, lighting bridge, or any gallery provided for similar purposes or for maintenance and repair);
- e. an external wall; and
- f. a compartment wall (including a wall common to two or more buildings). (However, see the guidance to B3, paragraph 8.4, for exclusions from the provisions for elements of structure.)

**Emergency lighting** Lighting provided for use when the supply to the normal lighting fails.

**Escape lighting** That part of the emergency lighting which is provided to ensure that the escape route is illuminated at all material times.

**Escape route** Route forming that part of the means of escape from any point in a building to a final exit.

**European Technical Approval** A favourable technical assessment of the fitness for use of a construction product for an intended use, issued for the purposes of the Construction Products Directive by a body authorised by a member State to issue European Technical Approvals for those purposes and notified by that member State to the European Commission.

**European Technical Approvals Issuing body** A body notified under Article 10 of the Construction Products Directive. The details of these institutions are published in the “C” series of the Official Journal of the European Communities.

**Evacuation lift** A lift that may be used for the evacuation of people in a fire.

**Exit passageway** A protected passageway connecting a protected stairway to a final exit (exit passageways should be protected to the same standard as the stairway they serve).

## Appendix E

### External wall

The external wall of a building includes a reference to:

- (i) anything located within any space forming part of the wall;
- (ii) any decoration or other finish applied to any external (but not internal) surface forming part of the wall;
- (iii) any windows and doors in the wall; and
- (iv) any part of a roof pitched at an angle of more than 70 degrees to the horizontal if that part of the roof adjoins a space within the building to which persons have access, but not access only for the purpose of carrying out repairs or maintenance.

**Final exit** The termination of an escape route from a building giving direct access to a street, passageway, walkway or open space and sited to ensure the rapid dispersal of persons from the vicinity of a building so that they are no longer in danger from fire and/or smoke.

**Note:** Windows are not acceptable as final exits.

**Fire damper** Mechanical or intumescent device within a duct or ventilation opening which is operated automatically and is designed to prevent the passage of fire and which is capable of achieving an integrity E classification and/or an ES classification to BS EN13501-3:2005 when tested to BS EN1366-2:1999. Intumescent fire dampers may be tested to ISO 10294-5.

**Fire and smoke damper** Fire damper which when tested in accordance with BS EN 1366-2:1999 meets the ES classification requirements defined in EN 13501-3:2005 and achieves the same fire resistance in relation to integrity, as the element of the building construction through which the duct passes. Intumescent fire dampers may be tested to ISO 10294-2.

**Fire door** A door or shutter, provided for the passage of persons, air or objects, which, together with its frame and furniture as installed in a building, is intended (when closed) to resist the passage of fire and/or gaseous products of combustion and is capable of meeting specified performance criteria to those ends. (It may have one or more leaves and the term includes a cover or other form of protection to an opening in a fire-resisting wall or floor, or in a structure surrounding a protected shaft.)

**Firefighting lift** A lift designed to have additional protection, with controls that enable it to be used under the direct control of the fire and rescue service in fighting a fire. (See Sections 16-18.)

**Firefighting lobby** A protected lobby providing access from a firefighting stair to the accommodation area and to any associated firefighting lift.

**Firefighting shaft** A protected enclosure containing a firefighting stair, firefighting lobbies and, if provided, a firefighting lift, together with its machine room.

## Appendix E

**Firefighting stair** A protected stairway communicating with the accommodation area only through a firefighting lobby.

**Fire-resisting (fire resistance)** The ability of a component or construction of a building to satisfy for a stated period of time, some or all of the appropriate criteria specified in the relevant standard test.

**Fire-separating element** A compartment wall, compartment floor, cavity barrier and construction enclosing a protected escape route and/or a place of special fire hazard.

**Fire stop** A seal provided to close an imperfection of fit or design tolerance between elements or components, to restrict the passage of fire and smoke.

**Flat** A separate and self contained premises constructed or adapted for use for residential purposes and forming part of a building from some other part of which it is divided horizontally.

**Gallery** A floor or balcony which does not extend across the full extent of a building's footprint and is open to the floor below.

**Habitable room** A room used, or intended to be used, for dwelling purposes (including for the purposes of Part B, a kitchen, but not a bathroom).

**Height** (of a building or storey for the purposes of Part B) Height of a building is measured as shown in Appendix C, Diagram C4 and height of the floor of the top storey above ground is measured as shown in Appendix C, Diagram C6.

**Inner room** Room from which escape is possible only by passing through another room (the access room).

**Live/Work Unit** A flat which is intended to serve as a workplace for its occupants and for persons who do not live on the premises.

**Material of limited combustibility** A material performance specification that includes non-combustible materials and for which the relevant test criteria are set out in Appendix A, paragraph 12.

**Means of escape** Structural means whereby [in the event of fire] a safe route or routes is or are provided for persons to travel from any point in a building to a place of safety.

**Measurement** Width of a doorway, area, cubic capacity, height of a building and number of storeys, see Appendix C, Diagrams C1 to C7; occupant capacity, travel distance and, escape route and a stair, see Appendix C.

**Non-combustible material** The highest level of reaction to fire performance. The relevant test criteria are set out in Appendix A, paragraph 11.

## Appendix E

**Notional boundary** A boundary presumed to exist between buildings on the same site (see Section 14, Diagram 42).

**Occupancy type** A purpose group identified in Appendix D.

**Open spatial planning** The internal arrangement of a building in which more than one storey or level is contained in one undivided volume, e.g. split-level floors. For the purposes of this document there is a distinction between open spatial planning and an atrium space.

**Perimeter (of a building)** The maximum aggregate plan perimeter, found by vertical projection onto a horizontal plane (see Section 17, Diagram 48).

**Pipe** (for the purposes of Section 11) – includes pipe fittings and accessories and excludes a flue pipe and a pipe used for ventilating purposes (other than a ventilating pipe for an above ground drainage system).

**Places of special fire hazard** Oil-filled transformer and switch gear rooms, boiler rooms, storage space for fuel or other highly flammable substances and rooms housing a fixed internal combustion engine.

**Platform floor** (access or raised floor) A floor supported by a structural floor, but with an intervening concealed space which is intended to house services.

**Protected circuit** An electrical circuit protected against fire.

**Protected corridor/lobby** A corridor or lobby which is adequately protected from fire in adjoining accommodation by fire-resisting construction.

**Protected entrance hall/landing** A circulation area consisting of a hall or space in a flat, enclosed with fire-resisting construction (other than any part which is an external wall of a building).

**Protected shaft** A shaft which enables persons, air or objects to pass from one compartment to another and which is enclosed with fire-resisting construction.

**Protected stairway** A stair discharging through a final exit to a place of safety (including any exit passageway between the foot of the stair and the final exit) that is adequately enclosed with fire-resisting construction.

**Purpose group** A classification of a building according to the purpose to which it is intended to be put. See Appendix D, Table D1.

**Relevant boundary** The boundary which the side of the building faces, (and/or coincides with) and which is parallel, or at an angle of not more than 80°, to the side of the building (see Section 14, Diagram 41). A notional boundary can be a relevant boundary.

## Appendix E

**Rooflight** A dome light, lantern light, skylight, ridge light, glazed barrel vault or other element intended to admit daylight through a roof.

**Room** (for the purposes of B2) An enclosed space within a building that is not used solely as a circulation space. (The term includes not only conventional rooms, but also cupboards that are not fittings and large spaces such as warehouses and auditoria. The term does not include voids such as ducts, ceiling voids and roof spaces.)

**School** A place of education for children older than 2 and younger than 19 years. Includes nursery schools, primary schools and secondary schools as defined in the Education Act 1996.

**Self-closing device** A device which is capable of closing the door from any angle and against any latch fitted to the door.

**Note:** Rising butt hinges which do not meet the above criteria are acceptable where the door is in a cavity barrier.

**Separated part** (of a building) A form of compartmentation in which a part of a building is separated from another part of the same building by a compartment wall. The wall runs the full height of the part and is in one vertical plane. (See paragraph 9.22 and Appendix C, Diagram C5.

**Sheltered housing includes:**

- a. two or more dwellings in the same building;
- b. two or more dwellings on adjacent sites where those dwellings are, in each case, designed and constructed for the purpose of providing residential accommodation for vulnerable or elderly people who receive, or who are to receive, a support service.

**Single storey building** A building consisting of a ground storey only. (A separated part which consists of a ground storey only, with a roof to which access is only provided for repair or maintenance, may be treated as a single storey building). Basements are not included in counting the number of storeys in a building (see Appendix C).

**Site** (of a building) is the land occupied by the building, up to the boundaries with land in other ownership.

**Smoke alarm** A device containing within one housing all the components, except possibly the energy source, necessary for detecting smoke and giving an audible alarm.

**Specified attachment:**

- (i) a balcony attached to an external wall;
- (ii) a solar panel attached to an external wall.

## Appendix E

**Storey** includes:

- a. any gallery in an assembly building (Purpose Group 5); and
- b. any gallery in any other type of building if its area is more than half that of the space into which it projects; and

**Note:** Where there is more than one gallery and the total aggregate area of all the galleries in any one space is more than half of the area of that space then the building should be regarded as being a multi storey building.

- c. a roof, unless it is accessible only for maintenance and repair.

**Storey exit** A final exit, or a doorway giving direct access into a protected stairway, firefighting lobby, or external escape route.

**Note:** A door in a compartment wall in an institutional building is considered as a storey exit for the purposes of B1 if the building is planned for progressive horizontal evacuation, see paragraph 4.41.

**Suspended ceiling** (fire-protecting) A ceiling suspended below a floor, which contributes to the fire resistance of the floor. Appendix A, Table A3, classifies different types of suspended ceiling.

**Technical specification** A standard or a European Technical Approval Guide. It is the document against which compliance can be shown in the case of a standard and against which an assessment is made to deliver the European Technical Approval.

**Thermoplastic material** See Appendix A, paragraph 20.

**Travel distance** (unless otherwise specified, e.g. as in the case of flats) The actual distance to be travelled by a person from any point within the floor area to the nearest storey exit, having regard to the layout of walls, partitions and fittings.

**Unprotected area** In relation to a side or external wall of a building means:

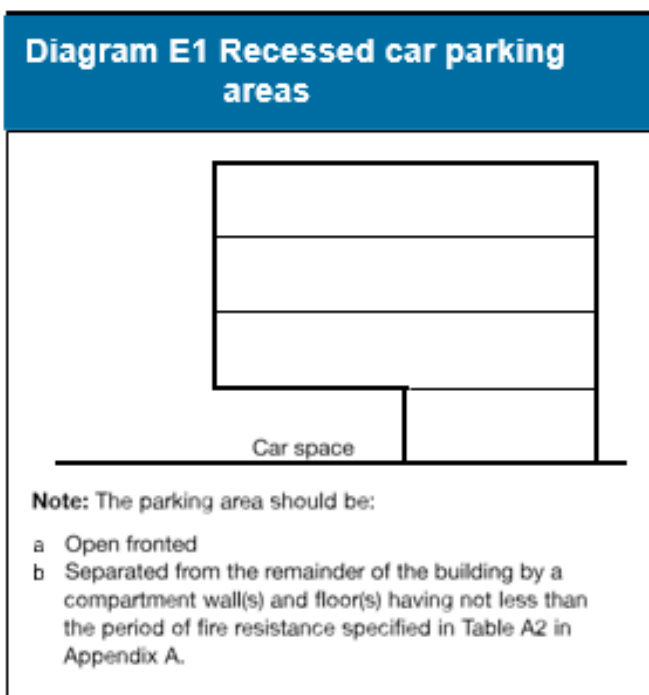
- a. window, door or other opening; and

**Note:** Windows that are not openable and are designed and glazed to provide the necessary level of fire resistance and recessed car parking areas shown in Diagram E1, need not be regarded as an unprotected area.

- b. any part of the external wall which has less than the relevant fire resistance set out in Section 13; and
- c. any part of the external wall which has combustible material more than 1mm thick attached or applied to its external face, whether for cladding or any other purpose. (Combustible material in this context is any material which does not have a Class 0 rating.)



## Appendix E



## Appendix F

---

# Fire behaviour of insulating core panels used for internal structures

1. Insulating core panel systems are used for external cladding as well as for internal structures. However, whilst both types of panel system have unique fire behaviour characteristics, it is those used for internal structures that can present particular problems with regard to fire spread.

The most common use of insulating core panels, when used for internal structures, is to provide an enclosure in which a chilled or sub zero environment can be generated for the production, preservation, storage and distribution of perishable foodstuffs. However this type of construction is also used in many other applications, particularly where the maintenance of a hygienic environment is essential.

These panels typically consist of an inner core sandwiched between and bonded to facings of galvanised steel, often with a PVC facing for hygiene purposes. The panels are then formed into a structure by jointing systems, usually designed to provide an insulating and hygienic performance. The panel structure can be free standing, but is usually attached to the building structure by lightweight fixings or hangers in the case of ceilings.

The most common forms of insulation in present use are:

- polyisocyanurate,
- mineral fibre,
- phenolic,
- polystyrene (cold stores),
- extruded polystyrene,
- composite polymers such as syntactic phenolic.

### Fire behaviour of the core materials and fixing systems

2. The degradation of polymeric materials can be expected when exposed to radiated/ conducted heat from a fire, with the resulting production of large quantities of smoke.

It is recognised that the potential for problems in fires involving mineral fibre cores is generally less than those for polymeric core materials.

In addition, irrespective of the type of core material, the panel, when exposed to the high temperatures of a developed fire, will tend to delaminate between the facing and core material, due to a combination of expansion of the metal facing and softening of the bond line.

## Appendix F

Therefore once it is involved, either directly or indirectly in a fire, the panel will have lost most of its structural integrity. Stability will then be dependant on the method of fixing to the structure. For systems that are not fixed through both facings the stability of the system will then depend on the residual structural strength of the non-exposed facing, the interlocking joint between panels and the fixing system.

Most jointing or fixing systems for these systems have an extremely limited structural integrity performance in developed fire conditions. If the fire starts to heat up the support fixings or structure to which they are attached, then there is a real chance of total collapse of the panel system.

Where panels are used as the lining to a building the insulating nature of these panels, together with their sealed joints, means that fire can spread behind the panels, hidden from the occupants of occupied rooms/spaces. With some thermoplastic cores fire can also spread between the panel facings.

This can prove to be a particular problem to firefighters as, due to the insulating properties of the cores, it may not be possible to track the spread of fire, even using infra red detection equipment. This difficulty, together with that of controlling the fire spread within and behind the panels, is likely to have a detrimental effect on the performance of the fixing systems, potentially leading to their complete and unexpected collapse, together with any associated equipment.

### Firefighting

3. When compared with other types of construction techniques, these panel systems therefore provide a unique combination of problems for firefighters, including:

- hidden fire spread within panels with thermoplastic cores;
- production of large quantities of black toxic smoke; and
- rapid fire spread leading to flashover.
- Hidden fire behind lining systems

These three characteristics are common to both polyurethane and polystyrene cored panels, although the rate of fire spread in polyurethane cores is significantly less than that of polystyrene cores, especially when any external heat source is removed.

In addition, irrespective of the type of panel core, all systems are susceptible to:

- delamination of the steel facing;
- collapse of the system; and
- hidden fire spread behind the system.

### Design recommendations

4. To identify the appropriate solution, a risk assessment approach should be adopted. This would involve identifying the potential fire risk within the enclosures formed by the panel systems and then adopting one or more of the following at the design stage:

## Appendix F

- removing the risk;
- separating the risk from the panels by an appropriate distance; providing a fire suppression system for the risk;
- providing a fire suppression system for the enclosure;
- providing fire-resisting panels; and
- specifying appropriate materials/fixing and jointing systems.

In summary the performance of the building structure, including the insulating envelope, the superstructure, the substructure etc, must be considered in relation to their performance in the event of a fire.

### Specifying panel core materials

5. Where at all possible the specification of panels with core materials appropriate to the application will help ensure an acceptable level of performance for panel systems, when involved in fire conditions.

The following are examples in the provision of core materials which may be appropriate to the application concerned.

### Mineral fibre cores:

- cooking areas,
- hot areas,
- bakeries,
- fire breaks in combustible panels,
- fire stop panels,
- general fire protection.

### All cores:

- chill stores,
- cold stores,
- blast freezers,
- food factories,
- clean rooms.

**Note:** Core materials may be used in other circumstances where a risk assessment has been made and other appropriate fire precautions have been put in place.

### Specifying materials/fixing and jointing systems

6. The following are methods by which the stability of panel systems may be improved in the event of a fire, although they may not all be appropriate in every case.

In addition the details of construction of the insulating envelope should, particularly in relation to combustible insulant cores, prevent the core materials from becoming exposed to the fire and contributing to the fire load:

## Appendix F

- a. Insulating envelopes, support systems and supporting structure should be designed to allow the envelope to remain structurally stable by alternative means such as catenary action following failure of the bond line between insulant core and facing materials. This particularly relates to ceilings and will typically require positive attachment of the lower faces of the insulant panels to supports.
- b. The building superstructure, together with any elements providing support to the insulating envelope, should be protected to prevent early collapse of the structure or the envelope.

**Note:** Irrespective of the type of panel provided, it will remain necessary to ensure that the supplementary support method supporting the panels remains stable for an appropriate time period under fire conditions. It is not practical to fire protect light gauge steel members such as purlins and sheeting rails which provide stability to building superstructures and these may be compromised at an early stage of a fire. Supplementary fire-protected heavier gauge steelwork members could be provided at wider intervals than purlins to provide restraint in the event of a fire.

- c. In designated high risk areas, consideration should be given to incorporating non-combustible insulant cored panels into wall and ceiling construction at intervals, or incorporating strips of non-combustible material into specified wall and ceiling panels, in order to provide a barrier to fire propagation through the insulant.
- d. Correct detailing of the insulating envelope should ensure that the combustible insulant is fully encapsulated by non-combustible facing materials which remain in place during a fire.
- e. The panels should incorporate pre-finished and sealed areas for penetration of services.

## General

7. Generally, panels or panel systems should not be used to support machinery or other permanent loads.

Any cavity created by the arrangement of panels, their supporting structure or other building elements should be provided with suitable cavity barriers.

8. Examples of possible solutions and general guidance on insulating core panels construction can be found in *Design, construction, specification and fire management of insulated envelopes for temperature controlled environments* published by the International Association of Cold Storage Contractors (European Division).

Of particular relevance is Chapter 8 of the document which gives guidance on the design, construction and management of insulated structures. Whilst the document is primarily intended for use in relation to cold storage environments, the guidance, particularly in Chapter 8, is considered to be appropriate for most insulating core panel applications.

## Appendix G

### Fire safety information

1. Regulation 38 requires that, where building work involves the erection or extension of a relevant building, or a relevant change of use of a building, fire safety information shall be given to the responsible person at the completion of the project or when the building or extension is first occupied.
  - “*fire safety information*” means information relating to the design and construction of the building or extension, and the services, fittings and equipment provided in or in connection with the building or extension which will assist the responsible person to operate and maintain the building or extension with reasonable safety;
  - a “*relevant building*” is a building to which the Regulatory Reform (Fire Safety) Order 2005 applies<sup>1</sup>, or will apply after the completion of building work;
  - a “*relevant change of use*” is a material change of use where, after the change of use takes place, the Regulatory Reform (Fire Safety) Order 2005 will apply, or continue to apply, to the building; and
  - “*responsible person*” has the meaning given in article 3 of the Regulatory Reform (Fire Safety) Order 2005.

This Appendix is only intended as a guide as to the kind of information that should be provided. For clarity the guidance is given in terms of simple and complex buildings, however the level of detail required will vary from building to building and should be considered on a case by case basis.

#### Simple buildings

2. For most buildings basic information on the location of fire protection measures may be all that is necessary. An as-built plan of the building should be provided showing:
  - a. escape routes;
  - b. compartmentation and separation (i.e. location of fire separating elements, including cavity barriers in walk-in spaces);
  - c. fire doors, self-closing fire doors and other doors equipped with relevant hardware (e.g. panic locks);
  - d. locations of fire and/or smoke detector heads, alarm call-points, detection/alarm control boxes, alarm sounders, fire safety signage, emergency lighting, fire extinguishers, dry or wet risers and other fire fighting equipment and location of hydrants outside the building;
  - e. any automatic fire suppression system(s), including isolating valves and control equipment;
  - f. any smoke-control system(s) (or ventilation system with a smoke-control function), including mode of operation and control systems;
  - g. any high-risk areas (e.g. heating machinery);
  - h. specifications of any fire safety equipment provided, in particular any routine maintenance schedules; and

## Appendix G

- i. any assumptions in the design of the fire safety arrangements regarding the management of the building.
- j. Any provision incorporated into the building to facilitate the evacuation of Disabled people. This information can then be used when designing suitable Personal Emergency Escape Plans.

### Complex buildings

3. For more complex buildings a more detailed record of the fire safety strategy and procedures for operating and maintaining any fire protection measures of the building will be necessary. Further guidance is available in BS5588-12:2004 *Fire precautions in the design, construction and use of buildings: Managing fire safety* (Annex A Fire Safety Manual.)

These records should include:

- a. The fire safety strategy, including all assumptions in the design of the fire safety systems (such as fire load). Any risk assessments or risk analysis.
- b. All assumptions in the design of the fire safety arrangements regarding the management of the building.
- c. Escape routes, escape strategy (e.g. simultaneous or phased) and muster points.
- d. Details of all passive fire safety measures, including compartmentation (i.e. location of fire separating elements), cavity barriers, fire doors, self-closing fire doors and other doors equipped with relevant hardware (e.g. electronic security locks), duct dampers and fire shutters.
- e. Fire detector heads, smoke detector heads, alarm call-points, detection/alarm control boxes, alarm sounders, emergency communications systems, CCTV, fire safety signage, emergency lighting, fire extinguishers, dry or wet risers and other fire fighting equipment, other interior facilities for the fire and rescue service, emergency control rooms, location of hydrants outside the building, other exterior facilities for the fire and rescue service.
- f. Details of all active fire safety measures, including:
  - Automatic fire suppression system(s) design, including isolating valves and control equipment (see also appendix H); and
  - Smoke-control system(s) (or HVAC system with a smoke-control function) design, including mode of operation and control systems.
- g. Any high-risk areas (e.g. heating machinery) and particular hazards,
- h. As-built plans of the building showing the locations of the above.
- i. Specifications of any fire safety equipment provided, including operational details, operators manuals, software, system zoning and routine inspection, testing and maintenance schedules. Records of any acceptance or commissioning tests.
- j. Any provision incorporated into the building to facilitate the evacuation of disabled people.
- k. Any other details appropriate for the specific building.

## Appendix H

---

# Maintenance of Residential Automatic Fire Suppression Systems

1. For an automatic fire suppression system to remain effective it is essential that it is maintained in line with the manufacturer's recommendations and also the relevant technical standard. As noted in paragraph 0.11 the Building Regulations do not impose any maintenance requirements but suitable information regarding the systems should be passed on to the building occupier (see appendix G).
2. Common areas of domestic premises area are covered by the regulatory reform fire safety order (RRFSO). Any residential automatic fire suppression system provided in common areas will therefore need to be maintained in line with Article 17 of the RRFSO.
3. Currently, the most appropriate technical standard for automatic fire suppression in a residential property is BS: 9251:2014 *Sprinkler systems for domestic and residential occupancies. Code of practice*. This British Standard suggests inspection and testing of the system should be carried out annually by a suitably qualified and experienced automatic fire suppression contractor to ensure that;
  - a. Heat sensing capacity and spray capacity of the sprinkler is not impeded.
  - b. Minimum flow rates (as recommended in BS: 9251) are achieved.
  - c. The alarm is effective and can be heard in all parts of the building.
  - d. The system has not been modified outside the scope of BS:9251.
  - e. If a material alteration has been undertaken an assessment of whether the category of the system is still appropriate
4. BS: 9251 recommends that testing should involve;
  - a. A visual inspection for leaks. If a leak is suspected the pipework should be tested at 1.5 times working pressure of a period of 1 hour
  - b. Alarms should be left active in order to determine their effectiveness
  - c. The systems should be tested for 1 minute at the drain and test valve or the highest point of installed pipework to ensure required flow rates are met
  - d. Stop valves exercised to ensure free movement
  - e. Check operation of trace heating, if installed
  - f. Documentation of inspection and tests should be recorded, giving details of;
    - i. Inspection date
    - ii. Details of tests and results
    - iii. Determination of system operational status
    - iv. Determination of alarm operational status
    - v. Details of any alarm actuation and subsequent re-instatement of the system
    - vi. Details of any alarm actuation and subsequent re-instatement of the system
    - vii. Recommendations or comments.



## Appendix I

---

### Standards and other publications referred to

**BS EN 54-11:2001**

Fire detection and fire alarm systems. Manual call points

**BS EN 81-58:2003**

Safety for the construction and installation of lifts – Examination and tests. Landing doors fire resistance test

**BS EN 81-72:2003**

Safety rules for the construction and installation of lifts. Particular applications for passenger and goods passenger lifts. Firefighters lifts

**BS EN 81-2:1998**

Safety rules for the construction and installation of lifts. Hydraulic lifts

**BS EN 81-1:1998**

Safety rules for the construction and installation of lifts. Electric lifts

**DD 252:2002**

Components for residential sprinkler systems. Specification and test methods for residential sprinklers

**BS EN ISO 306:2004**

Plastics. Thermoplastic materials. Determination of Vicat softening temperature (VST)

**BS 476-24:1987**

Fire tests on building materials and structures. Method for determination of the fire resistance of ventilation ducts

**BS 476-8:1972**

Fire tests on building materials and structures. Test methods and criteria for the fire resistance of elements of building construction (withdrawn)

**BS 476-23:1987**

Fire tests on building materials and structures. Methods for determination of the contribution of components to the fire resistance of a structure

**BS 476-22:1987**

Fire tests on building materials and structures. Methods for determination of the fire resistance of non-loadbearing elements of construction

## Appendix I

### **BS 476-4:1970**

Fire tests on building materials and structures. Non-combustibility test for materials

### **BS 476-21:1987**

Fire tests on building materials and structures. Methods for determination of the fire resistance of loadbearing elements of construction

### **BS 476-20:1987**

Fire tests on building materials and structures. Method for determination of the fire resistance of elements of construction (general principles)

### **BS 476-11:1982**

Fire tests on building materials and structures. Method for assessing the heat emission from building materials

### **BS 476-6:1989**

Fire tests on building materials and structures. Method of test for fire propagation for products

### **BS 476-7:1997**

Fire tests on building materials and structures. Method of test to determine the classification of the surface spread of flame of products

### **BS 476-3:2004**

Fire tests on building materials and structures. Classification and method of test for external fire exposure to roofs

### **BS EN 771-1:2003**

Specification for masonry units. Clay masonry units

### **BS EN 1634-2: 2008**

Fire resistance tests for door and shutter assemblies, Part 2 – Fire door hardware

### **BS EN 1125:1997**

Building hardware. Panic exit devices operated by a horizontal bar. Requirements and test methods

### **BS EN 1155:1997**

Building hardware. Electrically powered hold-open devices for swing doors. Requirements and test methods

### **BS EN ISO 1182:2002**

Reaction to fire tests for building products. Non-combustibility test

### **ENV 1187:2002+A1:2005, test 4**

Test methods for external fire exposure to roofs

### **BS EN 1364-1:1999**

Fire resistance tests for non-loadbearing elements. Walls

## Appendix I

### **BS EN 1364-2:1999**

Fire resistance tests for non-loadbearing elements. Ceilings

### **BS EN 1364-3:2006**

Fire resistance tests for non-loadbearing elements. Curtain walling. Full configuration (complete assembly)

### **BS EN 1365-1:1999**

Fire resistance tests for loadbearing elements. Walls

### **BS EN 1365-2:2000**

Fire resistance tests for loadbearing elements. Floors and roofs

### **BS EN 1365-3:2000**

Fire resistance tests for loadbearing elements. Beams

### **BS EN 1365-4:1999**

Fire resistance tests for loadbearing elements. Column

### **BS EN 1366-1:1999**

Fire resistance tests for service installations. Fire resistance tests for service installations. Ducts

### **BS EN 1366-2:1999**

Fire resistance tests for service installations. Fire dampers

### **BS EN 1366-3:2004**

Fire resistance tests for service installations. Penetration seals

### **BS EN 1366-4:2006**

Fire resistance tests for service installations. Linear joint seals

### **BS EN 1366-5:2003**

Fire resistance tests for service installations. Service ducts and shafts

### **BS EN 1366-6:2004**

Fire resistance tests for service installations. Raised access and hollow core floors

### **BS EN 1634-1:2008**

Fire resistance tests for door and shutter assemblies. Fire doors and shutters

### **BS EN 1634-2:2008**

Fire resistance and smoke control tests for door and shutter assemblies, openable windows and elements of building hardware. Fire resistance characterisation test for elements of building hardware

## Appendix I

### **BS EN 1634-3:2004**

Fire resistance tests for door and shutter assemblies. Smoke control doors and shutters

### **BS EN ISO 1716:2002**

Reaction to fire tests for building products. Determination of the heat of combustion

### **BS 2782-0:2004**

Methods of testing. Plastics. Introduction

### **BS 3251:1976**

Specification. Indicator plates for fire hydrants and emergency water supplies

### **BS 4514:2001**

Unplasticized PVC soil and ventilating pipes of 82.4mm minimum mean outside diameter, and fittings and accessories of 82.4mm and of other sizes. Specification

### **BS 5255:1989**

Specification for thermoplastics waste pipe and fittings

### **BS 5266-1:2005**

Emergency lighting. Code of practice for the emergency lighting of premises

### **BS 5306-2:1990**

Fire extinguishing installations and equipment on premises. Specification for sprinkler systems

### **BS 5395-2:1984**

Stairs, ladders and walkways. Code of practice for the design of helical and spiral stairs

### **BS 5438:1989**

Methods of test for flammability of textile fabrics when subjected to a small igniting flame applied to the face or bottom edge of vertically oriented specimens

### **BS EN 14604:2005**

Smoke alarm devices for dwellings.

### **BS 5446-2:2003**

Fire detection and fire alarm devices for dwellings. Specification for heat alarms

### **BS 5499-1:2002**

Graphical symbols and signs. Safety signs, including fire safety signs. Specification for geometric shapes, colours and layout

### **BS 5499-1:2002**

Graphical symbols and signs. Safety signs, including fire safety signs. Specification for geometric shapes, colours and layout

## Appendix I

### **BS 5588-1:1990**

Fire precautions in the design, construction and use of buildings. Code of practice for residential buildings

### **BS 5588-5:2004**

Fire precautions in the design, construction and use of buildings. Access and facilities for fire-fighting

### **BS 5588-6:1991**

Fire precautions in the design, construction and use of buildings. Code of practice for places of assembly

### **BS 5588-7:1997**

Fire precautions in the design, construction and use of buildings. Code of practice for the incorporation of atria in buildings

### **BS 5588-8:1999**

Fire precautions in the design, construction and use of buildings. Code of practice for means of escape for disabled people

### **BS 5588-9:1999**

Fire precautions in the design, construction and use of buildings. Code of practice for ventilation and air conditioning ductwork

### **BS 5588-10:1991**

Fire precautions in the design, construction and use of buildings. Code of practice for shopping complexes

### **BS 5588-11:1997**

Fire precautions in the design, construction and use of buildings. Code of practice for shops, offices, industrial, storage and other similar buildings

### **BS 5588-12:2004**

Fire precautions in the design, construction and use of buildings. Managing fire safety

### **BS 5720:1979**

Code of practice for mechanical ventilation and air conditioning in buildings

### **BS 5839-8:1998**

Fire detection and fire alarm systems for buildings. Code of practice for the design, installation, commissioning, and maintenance of voice alarm systems

### **BS 5839-1:2002**

Fire detection and fire alarm systems for buildings. Code of practice for system design, installation, commissioning and maintenance

## Appendix I

### **BS 5839-6:2004**

Fire detection and fire alarm systems for buildings. Code of practice for the design, installation and maintenance of fire detection and fire alarm systems in dwellings

### **BS 5839-9:2003**

Fire detection and alarm systems for buildings. Code of practice for the design, installation, commissioning and maintenance of emergency voice communication systems

### **BS 5867-2:1980**

Specification for fabrics for curtains and drapes. Flammability requirements

### **BS 5950-8:2003**

Structural use of steelwork in building. Code of practice for fire resistant design

### **BS 6336:1998**

Guide to the development of fire tests, the presentation of test data and the role of tests in hazard assessment

### **BS 7157:1989**

Method of test for ignitability of fabrics used in the construction of large tented structures

### **BS 7273-2:1992**

Code of practice for the operation of fire protection measures. Mechanical actuation of gaseous total flooding and local application extinguishing systems

### **BS 7273-3:2000**

Code of practice for the operation of fire protection measures. Electrical actuation of pre-action sprinkler systems

### **BS 7273-1:2006**

Code of practice for the operation of fire protection measures. Electrical actuation of gaseous total flooding extinguishing systems

### **BS 7346-6:2005**

Components for smoke and heat control systems. Specifications for cable systems

### **BS 7346-7:2006**

Components for smoke and heat control systems. Code of practice on functional recommendations and calculation methods for smoke and heat control systems for covered car parks

### **BS 7974:2001**

Application of fire safety engineering principles to the design of buildings. Code of practice

## Appendix I

### **BS 8414-2:2015+A1:2017**

Fire performance of external cladding systems. Test method for non-loadbearing external cladding systems fixed to and supported by a structural steel frame

### **BS 8414-1:2015+A1:2017**

Fire performance of external cladding systems. Test methods for non-loadbearing external cladding systems applied to the masonry face of a building

### **BS 8214:1990**

Code of practice for fire door assemblies with non-metallic leaves

### **BS 8214:1990**

Code of practice for fire door assemblies with non-metallic leaves

### **BS 8313:1997**

Code of practice for accommodation of building services in ducts

### **BS 9251:2014**

Sprinkler systems for domestic and residential occupancies. Code of practice

### **BS9252: 2011**

Components for residential sprinkler systems. Specification and test methods for residential sprinklers

### **BS 9990:2006**

Code of practice for non-automatic fire-fighting systems in buildings

### **BS9991: 2011**

Fire safety in the design, management and use of residential buildings – Code of practice

### **BS ISO 10294-2:1999**

Fire-resistance tests. Fire dampers for air distribution systems. Classification, criteria and field of application of test results

### **BS ISO 10294-5:2005**

Fire-resistance tests. Fire dampers for air distribution systems. Intumescent fire dampers

### **BS EN ISO 11925-2:2002**

Reaction to fire tests. Ignitability of building products subjected to direct impingement of flame. Single-flame source test

### **BS EN 12101-3:2002**

Smoke and heat control systems. Specification for powered smoke and heat exhaust ventilators

### **BS EN 12101-3:2002**

Smoke and heat control systems. Specification for powered smoke and heat exhaust ventilators

## Appendix I

### **BS EN 12101-6:2005**

Smoke and heat control systems. Specification for pressure differential systems. Kits

### **BS EN 12845:2004**

Fixed firefighting systems. Automatic sprinkler systems. Design, installation and maintenance

### **BS EN 13238:2001**

Reaction to fire tests for building products. Conditioning procedures and general rules for selection of substrates

### **BS EN 13501-1:2018**

Fire classification of construction products and building elements. Classification using test data from reaction to fire tests

### **BS EN 13501-2:2007**

Fire classification of construction products and building elements. Classification using data from fire resistance tests, excluding ventilation services

### **BS EN 13501-3:2005**

Fire classification of construction products and building elements. Classification using data from fire resistance tests on products and elements used in building service installations: fire resisting ducts and fire dampers

### **BS EN 13501-4:2007**

Fire classification of construction products and building elements, Part 4 – Classification using data from fire resistance tests on smoke control systems

### **BS EN 13501-5:2005**

Fire classification of construction products and building elements. Classification using data from external fire exposure to roof tests

### **BS EN 13823:2002**

Reaction to fire tests for building products. Building products excluding floorings exposed to the thermal attack by a single burning item

### **BS EN 15725:2010**

Extended application reports on the fire performance of construction products and building elements

### **BS EN 50200:2006**

Method of test for resistance to fire of unprotected small cables for use in emergency circuits



## Publications

### Publications Legislation

Disability Discrimination Act 1995

Education Act 1996

Pipelines Safety Regulations 1996, SI 1996 No 825 and the Gas Safety (Installation and Use) Regulations 1998 SI 1998 No 2451

Electromagnetic Compatibility Regulations 1992 (SI 1992 No 2372)

Electromagnetic Compatibility (Amendment) Regulations 1994 (SI 1994 No 3080)

Electrical Equipment (Safety) Regulations 1994 (SI 1994 No 3260)

Commission Decision 2000/553/EC of 6<sup>th</sup> September 2000 implementing Council Directive 89/106/EEC

(European tests) Commission Decision 2000/367/ EC of 3rd May 2000 implementing Council Directive 89/106/EEC

Commission Decision 2001/671/EC of 21 August 2001 implementing Council Directive 89/106/EC as regards the classification of the external fire performance of roofs and roof coverings

Commission Decision 2005/823/EC of 22 November 2005 amending Decision 2001/671/ EC regarding the classification of the external fire performance of roofs and roof coverings

Commission Decision 2000/147/EC of 8th February 2000 implementing Council Directive 89/106/EEC

Commission Decision 2000/367/EC of 3rd May 2000 implementing Council Directive 89/106/EEC

Commission Decision 96/603/EC of 4th October 1996 94/61 1/EC implementing Article 20 of the Council Directive 89/106/EEC on construction products

Construction Products Regulations 1991 (SI 1991 No 1620)

Construction Product (Amendment) Regulations 1994 (SI 1994 No 3051)

The Domestic Fire Safety (Wales) Measure 2011 (nawm 3)

The Workplace (Health, Safety and Welfare) Regulations 1992

Health and Safety (Safety signs and signals) Regulations 1996

## Publications

### **Association for Specialist Fire Protection (ASFP)**

ASFP Red book – Fire stopping and penetration seals for the construction industry 2nd Edition ISBN: 1 87040 923 X

ASFP Yellow book – Fire protection for structural steel in buildings 4th Edition ISBN: 1 87040 925 6

ASFP Grey book – Fire and smoke resisting dampers ISBN: 1 87040 924 8

ASFP Blue book – Fire resisting ductwork 2<sup>nd</sup> Edition ISBN: 1 87040 926 4

[www.asfp.org.uk](http://www.asfp.org.uk)

### **The British Automatic Sprinkler Association (BAFSA)**

Sprinklers for Safety: Use and Benefits of Incorporating Sprinklers in Buildings and Structures, (2006) ISBN: 0 95526 280 1

The Benefits of Automatic Fire Suppression Systems in Residential Care Premises, BAFSA 2009

[www.bafsa.org.uk](http://www.bafsa.org.uk)

### **Building Research Establishment Limited (BRE)**

BRE Digest 208 Increasing the fire resistance of existing timber floors 1988 ISBN: 978 1 86081 359 7

BRE report (BR 368) Design methodologies for smoke and heat exhaust ventilation 1999 ISBN: 978 1 86081 289 7

BRE report (BR 274) Fire safety of PTFE-based materials used in buildings 1994 ISBN: 978 186081 653 6

BRE report (BR 135) Fire performance of external thermal insulation for walls of multi-storey buildings 2013 ISBN: 978 1 84806 234 4

BRE report (BR 187) *External fire spread: Building separation and boundary distances* 1991 ISBN: 978 1 86081 465 5

BRE report (BR128) *Guidelines for the construction of fire resisting structural elements* 1988 ISBN: 0 85125 293 1

BRE 454 Multi-storey timber frame buildings – a design guide 2003 ISBN: 1 86081 605 3  
[www.bre.co.uk](http://www.bre.co.uk)

## Publications

### **Builders Hardware Industry Federation and Guild of Architectural Ironmongers**

*Hardware for Fire and Escape Doors* 2006 ISBN: 0 95216 422 1

[www.firecode.org.uk](http://www.firecode.org.uk)

### **Department for Communities and Local Government**

Regulatory Reform (Fire Safety) Order 2005 ISBN: 0 11072 945 5

Fire safety in adult placements: a code of practice

[www.communities.gov.uk](http://www.communities.gov.uk)

Fire Performance of Green Roofs and Walls 2013 ISBN: 978 1 4098 3997 2

### **Department for Education and Skills**

Building Bulletin (BB) 100

[www.dfes.gov.uk](http://www.dfes.gov.uk)

### **Department of Health**

HTM 05 – 02 Guidance in support of functional provisions for healthcare premises

[www.dh.gov.uk](http://www.dh.gov.uk)

### **Door and Shutter Manufacturers' Association (DSMA)**

Code of practice for fire-resisting metal doorsets 1999

[www.dhfonline.org.uk](http://www.dhfonline.org.uk)

### **Natural Resources Wales**

Pollution Prevention Guidelines (PPG18)

Managing Fire Water and Major Spillages

[www.naturalresourceswales.gov.uk](http://www.naturalresourceswales.gov.uk)

### **Football Licensing Authority**

Concourses ISBN: 0 95462 932 9 [www.flaweb.org.uk/home.php](http://www.flaweb.org.uk/home.php)

### **Fire Protection Association (FPA)**

Design guide

[www.thefpa.co.uk](http://www.thefpa.co.uk)

## Publications

### **Glass and Glazing Federation (GGF)**

A guide to best practice in the specification and use of fire-resistant glazed systems

[www.ggf.org.uk](http://www.ggf.org.uk)

### **Health and Safety Executive (HSE)**

Workplace health, safety and welfare, The Workplace (Health, Safety and Welfare) Regulations 1992, Approved Code of Practice and Guidance; The Health and Safety Commission, L24; published by HMSO 1992; ISBN: 0 11886 333 9

[www.hse.gov.uk](http://www.hse.gov.uk)

### **International Association of Cold Storage Contractors (IACSC)**

Design, construction, specification and fire management of insulated envelopes for temperature controlled environments 1999

[www.iarw.org/iacsc/european\\_division](http://www.iarw.org/iacsc/european_division)

### **Passive Fire Protection Federation**

Ensuring best practice for passive fire protection in buildings ISBN: 1 87040 919 1

[www.pfpf.org](http://www.pfpf.org)

Guide to undertaking technical assessments of the fire performance of construction products based on fire test evidence 2019

### **Steel Construction Institute (SCI)**

SCI P197 Designing for structural fire safety: A handbook for architects and engineers 1999 ISBN: 1 85942 07 4 5

SCI Publication 288 Fire safe design: A new approach to multi-storey steel-framed buildings (Second Edition) 2000 ISBN: 1 85942 169 5

SCI Publication P313 Single storey steel framed buildings in fire boundary conditions 2002 ISBN: 1 85942 135 0

[www.steel-sci.org](http://www.steel-sci.org)

### **Timber Research and Development Associations (TRADA)**

Timber Fire-Resisting Doorsets: maintaining performance under the new European test standard ISBN: 1 90051 035 9

[www.trada.co.uk](http://www.trada.co.uk)

# Index

## A

### Access control

Effect on escape routes 4.7

### Access corridors

See Corridor access

### Access for fire service

See Fire service facilities

### Access panels

Fire protecting suspended ceilings  
Table A3

### Access rooms

Definition Appendix E  
Horizontal escape 4.10,  
Diagram 12  
Escape from flats 3.5

### Accommodation stairs 5.32

Definition Appendix E

### Accreditation

Installers and suppliers 0.16,

### Aggregate notional area

Space separation 14.15

### Air changes

See Ventilation

### Air circulation systems for heating, etc.

Flats with a floor more than  
4.5m above ground  
level 3.18

### Air conditioning 6.46–6.53

See also Ventilation

### Air supported structures 7.8

### Aisles

Fixed seating 4.20, 6.29

### Alarm systems

Phased evacuation 1.25,  
5.26–5.29  
See also Automatic fire  
detection and alarm system

### Alterations

Material alteration 0.18  
Fire detection and  
alarm systems 1.6

### Alternative escape routes B1.v, B1.vii

Definition Appendix E  
Flats 3.20  
Horizontal escape 4.3, 4.5,  
4.9  
Diagram 11  
Small premises 4.37  
Sub-division of  
corridors 4.26  
Provision of cavity  
barriers 10.6

### Alternative exits Definition

Appendix E  
Fire doors Table B1  
Flats  
Balconies 3.7

Floor more than 4.5m  
above ground  
2.13–2.17, Diagrams 4  
and 5  
Galleries 3.8

### Amusement arcades

Floor space factors Table C1

### Ancillary accommodation

Escape routes  
Flats 3.30, 3.46–3.47  
Residential care  
homes 4.44

### Ancillary use

Purpose groups Appendix  
D(3)–(5)

### Appliance ventilation ducts

Compartments 9.34, 11.16  
Definition Appendix E

### Approved documents page 1

### Architraves

Definition of wall and ceiling  
7.2, 7.3

### Area

Methods of measurement Diagram  
C3

### Art galleries

Floor space factors Table C1

### Artificial lighting

See Lighting

### Assembly and recreation

#### purpose group 0.24

Automatic fire detection and alarm  
systems 1.33

Compartmentation 9.18

Counting number of storeys

Diagram C5

Door fastenings on escape

routes 6.12

Escape lighting Table 9

Escape route design 4.1

External escape stairs 5.44

External walls 13.2, Diagram 40

Fire doors Table B1

Floor space factors Table C1

Junction of compartment wall with  
roof 9.30

Maximum dimensions of building or  
compartment Table 12

Mechanical ventilation 6.51

Minimum periods of fire resistance  
Table A2

Minimum width of escape stairs  
Table 6

Purpose groups Table D1

Simultaneous evacuation 5.23

Single escape routes 4.5

Space separation 14.2

Acceptable unprotected areas  
14.16, 14.20

Notional boundaries 14.6

Permitted unprotected areas in  
small buildings or  
compartments Table 15

Spacing of fixed seating 4.20

Travel distance limitations Table 2

### Atria

Compartmentation 9.8, 9.34

Definition Appendix E

Fire protection of lift installations 6.41

Fire safety measures 0.26

Space separation 14.18

### Auditoria

See Assembly and recreation  
purpose group

### Automated storage systems

See Storage and other non-  
residential

### Automatic doors

Automatic release mechanism  
Automatic fire detection and  
alarm system 1.36

Definition Appendix E

Holding open self-closing fire  
doors Appendix B(3)

Automatic self-closing devices

Definition Appendix E

Fire doors Appendix B(2)

Holding open fire doors  
Appendix B(3)

Residential care homes 4.51

Sub-division of corridors 4.26

Escape routes 6.18

### Automatic fire dampers

See Fire dampers

### Automatic fire detection and alarm system

Activation of air extraction  
system 19.14

Activation of fire dampers 11.13

Automatic operation of smoke  
vents 3.26, 6.49

Buildings other than flats

1.24–1.38

Residential care homes 4.47

Flats 1.2–1.23, 3.16, 3.26

Inner rooms 4.10

Interface with other

systems 1.38

Maximum dimensions of concealed  
spaces 10.12

Mechanical ventilation and air  
conditioning systems 6.49

Positioning of smoke and

heat alarms 1.9–1.18

Power supply 1.19–1.22

Raised storage areas 8.8

Requirement B1 page 16

Staged alarm systems 1.25

Storeys divided into different  
occupancies 4.16

Types of system 1.30

Voice alarm systems 1.32

### Automatic fire suppression system

2.1, 2.2, 2.3, 2.4, 2.6, 2.7, 2.8, 2.9, 2.10, 5.29

Discounting of stairs 5.20

Flats 3.16

Maximum dimensions of building  
or compartment

Non-residential buildings Table 12

Mechanical smoke extract 19.13

Number and location of firefighting  
shafts 18.9

Permitted unprotected areas in small  
building or compartments Table 16

Portal frames 13.4

Residential care homes 4.52

Space separation 14.2

Boundary distance  
14.17

### Automatic opening vents

Escape routes for flats 3.26, 6.49,  
Diagrams 7 and 8

### Automatic release mechanism

Automatic fire detection and  
alarm system 1.36

Definition Appendix E

Holding open self-closing fire doors  
Appendix B(3)

### Automatic self-closing devices

Definition Appendix E

Fire doors Appendix B(2)

## Index

- Holding open fire doors Appendix B(3) Residential care homes 4.51  
Sub-division of corridors 4.26
- B**
- Balconies**  
Means of escape from flats 3.7, 3.17, 3.22
- Bars**  
Escape lighting Table 9  
Floor space factors Table C1
- Basement storeys**  
Car parks 12.3, 12.6, 19.17  
Compartmentation 9.18  
Counting the number of storeys Diagram C5  
Definition Appendix E  
Firefighting shafts 18.1–18.2, 18.4–18.5, Diagram 51  
Fire protection of lift installations 6.43, 6.44  
Fire resistance of elements of structure 8.3, Table A2  
Means of escape 5.41–5.43  
Added protection 5.34  
Capacity of a stair Table 7  
Construction of escape stairs 6.19  
Escape routes clear of smoke vents 19.12  
Final exits clear of smoke vents 6.34  
Flats 3.6, 3.43 3.45  
Simultaneous evacuation 5.23  
Single escape stairs 5.5  
Underground accommodation escape lighting Table 9  
Venting of heat and smoke 19.1–19.17
- Bathrooms**  
Smoke alarms 1.16
- Beams**  
Fire resistance 7.2, 9.27  
Tests Table A1  
Timber, in compartment walls 9.20
- Bedroom corridors**  
Limitations on travel distance Table 2  
Uninsulated glazed elements on escape routes Table A4
- Bedrooms**  
Flats with alternative exits 2.14  
Floor space factors Table C1
- Bedrooms**  
Flats with alternative exits 3.14  
Floor space factors Table C  
Inner rooms 4.10  
Limitations on travel distance Table 2  
Partitions and provision of cavity barriers 10.7  
Positioning smoke alarms 1.9  
Residential care homes 4.48, 4.49
- Bed-sitting rooms**  
Floor space factors Table C1
- Betting offices**  
Floor space factors Table C1
- Billiard rooms**  
Floor space factors Table C1
- Bingo halls**  
Floor space factors Table C1
- Boiler rooms**  
Common stairs 3.46  
Location of final exits 6.34  
Smoke alarms 1.17  
See also Plant rooms
- Bolts**  
See Fastenings
- Boundaries** 14.4  
Definition Appendix E  
Space separation for buildings fitted with sprinklers 14.17  
See also Notional boundaries; Relevant boundaries
- Bridges**  
Fire service vehicle access route specification Table 20
- British Standards** pages 229–239, 0.20 476 11.15, Appendix A(21)  
Part 3 15.4, Appendix A(6)  
Part 4 B2.v, Appendix A(8), Table A6  
Part 6 B2.v, Appendix A(12), Appendix A(15), Appendix A(20)  
Part 7 B2.v, 15.7, Appendix A(11), Appendix A(15), Appendix A(20)  
Part 8 Appendix A(5), Table A1, Table B1  
Part 11 B2.v, Appendix A(8)–A(9), Table A6–A7  
Part 22 Appendix B(1), Table B1  
Parts 20–24 Appendix A(5), Table A1  
2782 Appendix A(20), Appendix A(21)  
3251 16.7  
4514 Table 14  
5255 Table 14  
5266  
Part 1 3.52, 6.36, 6.38  
5306  
Part 2  
5438 Appendix A(20)  
5446  
Part 1 1.5  
Part 2 1.5  
5499  
Part 1 6.37  
Part 5 Appendix B(8)  
5588 11.14  
Part 1 3.2, 3.22  
Part 5 9.42, 14.8, 18.13, Diagram 52  
Part 6 0.24, 4.20, 6.29, 6.51  
Part 7 0.26, 1.36, 5.23, 9.8, 9.34 , 14.18  
Part 8 6.39  
Part 9 10.12  
Part 10 0.23, 9.18, 12.8, 18.7, Table 2  
Part 11 4.24  
5720 6.53  
5839  
Part 1 1.22, 1.26, 1.30, 1.31, 1.33, 1.34, 1.35, 1.36, 5.29, 6.38, 6.53, 8.8, 10.12, 11.13 19.14  
Part 2 1.31  
Part 6 1.4, 1.5, 1.9, 1.22  
Part 8 1.32, 5.29  
6587  
Part 2 Appendix A(20)  
6336 Appendix A(21)  
7157 7.8  
7273 1.38  
7346  
Part 6 6.38  
Part 7 12.6  
7974 0.29  
8214 Appendix B(11)  
8313 9.41  
9251 2.4, 2.5, 2.7  
9252 2.4
- 9990 16.6  
12101  
Part 2 Appendix C(5)  
13501  
Part 1 Appendix A(15)  
EN 54-11 1.31, 6.11  
EN 81 18.13  
EN 771  
Part 1 Table A6  
EN 1125 6.12  
EN 1155 4.51  
EN 1364 Appendix A(5)  
EN 1365 Appendix A(5)  
EN 1366 Appendix A(5)  
Part 2 11.15  
EN 1634 Appendix A(5), Appendix B(1) Part 3 Table B1  
EN 12101 3.27, 12.6  
Part 3 19.14  
Part 6 4.27, 5.21  
EN 12845 2.4, 2.8  
EN 13238 Appendix A(7) EN 13501  
Part 1 B2.v, Appendix A(7)–A(9), Appendix A(11), Table A6, Table A7  
Part 2 Appendix A(5), Appendix B(1) Part 3 11.15, Appendix A(5)  
Part 4 Appendix A(5)  
Part 5 14.4, Appendix A(6)  
EN 13823 B2.v, Appendix A(7), Appendix A(9) EN 50200  
5.38  
EN ISO 306 Appendix A(17)  
EN ISO 1182 B2.v, Appendix A(7)–A(9)  
EN ISO 1716 B2.v, Appendix A(7)–A(9)  
EN ISO 11925  
Part 2 B2.v, Appendix A(7) PD 6520 Appendix A(21)
- Building footprint**  
See Perimeter of building
- Buildings of architectural or historical interest**  
Fire safety 0.33
- Bulkheads**  
Smoke outlet shafts and ducts 19.15
- C**
- Cables**  
See Electrical wiring
- Canopies** 14.11, Diagram 45
- Capacity**  
See Occupant capacity
- Care homes**  
See Residential care homes
- Car parks**  
Common stairs 3.46  
Enclosed  
Fire protection of lift installations 6.43  
Escape lighting Table 9  
Floor space factors Table C1  
Internal fire spread 12.2–12.6  
Maximum dimensions of building or compartment Table 12  
Minimum periods of fire resistance Table A2  
Non-combustible materials Table A6  
Open-sided 12.3  
Height of building or compartment 14.20  
Separation distances Table 16  
Recessed areas Diagram E1  
Single-stair buildings 3.21

## Index

- Smoke venting from basement 19.17
- Cavity barriers**
- Cavity walls excluded Diagram 34
  - Concealed floor or roof spaces 7.6
  - Construction and fixings 10.13–10.16
  - Definition Appendix E
  - Double-skinned insulated roof sheeting Diagram 36
  - Extensive ceiling voids 10.11
  - External walls 13.8, 13.9
  - Fire doors Table B1
  - Fire resistance tests Table A1
  - Junctions with compartment floors and walls 10.3
  - Maximum dimensions 10.9–10.12
  - Openings 10.16
  - Provision 10.2, Diagram 33
  - Sub-division of corridors 4.26, Diagram 16
- Cavity walls**
- Excluded from provisions for cavity barriers Diagram 34
  - Junctions with compartment floors and walls 10.3
  - See also Insulation
- Ceilings**
- Concealed spaces 10.1
  - Definition Appendix E
  - Enclosure of corridors partitions 4.25
  - Extensive concealed spaces 10.11, 10.12
  - Fire resistance tests Table A1
  - Fire-resisting
    - Concealed spaces 7.6, 10.10, Diagram 35
  - Lighting diffusers that form part of 7.13–7.15, Diagram 26
  - Limited combustibility materials Table A7
  - Linings B2.i, 7.1–7.16
    - Definitions 7.2–7.3
  - Non-combustible materials Table A6
  - Stretched skin 7.16
  - Sub-division of corridors 4.26
  - Surfaces exposed 7.15
  - See also Suspended ceilings
- CE mark** page 4,
- Central alarm monitoring**
- Sheltered housing 1.7
- Central cores**
- See Exits
- Central handrails**
- Width of escape stairs 5.15–5.17
- Certification**
- Installers and suppliers 0.16, 1.23
- Chimneys**
- Openings in compartment walls or floors 9.34
- Chutes**
- Unacceptable means of escape B1.vi
  - See also Refuse chutes
- Circulation spaces**
- Definition Appendix E
  - Fire spread B1.iii
  - Glazing external windows with thermoplastic materials 7.11
  - Separating circulation routes from stairways 4.14
  - Smoke alarms/detectors positioning 1.9, 1.14
  - Wall and ceiling linings B2.i, Table 10
  - See also Corridors; Lobbies; Stairs
- Cladding**
- Concealed spaces 10.10
  - Elements of structure B3.iii
  - External wall construction 13.5
- Class 0**
- Definition Appendix E
  - Material and product performance Appendix A(13), Table A8
  - Use of materials of limited combustibility Table A7
- Cloakrooms**
- Protected stairways 5.38
- Clubs**
- Floor space factors Table C1
- Collapse, resistance to**
- B3.ii, Appendix A(5)
  - See also Integrity
- Columns**
- Fire resistance 8.2
  - Tests Table A1
  - Portal frames 13.4
- Combustible external surface materials** 14.1
- Unprotected area 14.9, Diagram 43
- Commercial**
- See Shop and commercial purpose group
- Committee rooms**
- Floor space factors Table C1
- Common balconies** Definition Appendix E
- Means of escape from flats 3.7, 3.17, 3.22
- Common corridors**
- Escape routes for flats 3.20, 3.24
  - Escape lighting Table 9
  - Ventilation 3.25–3.27
- Storeys divided into different occupancies 4.16
  - Sub-division of common escape routes 3.28, 3.29
- Common escape routes**
- See Common corridors; Common stairs;
- Common loadbearing elements**
- See Elements of structure
- Common rooms**
- Floor space factors Table C1
- Common stairs** Definition Appendix E
- Escape lighting Table 9
  - Flats 3.17, 3.20, 3.32–3.52, Diagrams 7–9
- Communication systems**
- Emergency voice communication (EVC) for evacuation from refuges 5.11, 5.12
  - Phased evacuation 5.29
  - Voice alarm systems 1.33, 5.29
- Compartment floors** Diagram 29
- Construction 9.20–9.31
  - Definition Appendix E
  - Fire doors in Table B1
  - Flues Diagram 39
  - Illustration of guidance Diagram 28
  - Nominal internal diameter of pipes passing through Table 14
  - Openings 9.34
  - Phased evacuation 5.29
  - Provision 9.9, 9.10
- Compartments** 9.1–9.42, Diagram 29
- Acceptable unprotected area 14.20, Table 15
  - Application of purpose groups Appendix D(1)
  - Basements, direct access to venting 19.3
  - Definition Appendix E
  - Escape from flats 3.3
  - Flues etc. 11.16
  - Maximum dimensions Table 12
  - Measuring areas Diagram C3
  - Progressive horizontal evacuation 4.41, 4.42
  - Protection of lift installations 6.42
  - Refuges Diagram 20
  - Shopping complexes 12.7
  - Space separation 14.2, 14.3, 14.10
  - Steel-framed buildings 9.27
- Compartment walls** Diagram 29
- Between buildings 9.21
  - Construction 9.20–9.31
  - Junctions 9.25–9.31, Diagram 30
  - Openings 9.32–9.34, Appendix B(5)
  - Definition Appendix E
  - Elements of structure B3.iii
  - Fire doors in Table B1
  - Fire resistance tests Table A1
  - Between flat and corridor 3.24
  - Flues penetrating Diagram 39
  - Nominal internal diameter of pipes passing through Table 14
  - Provision 9.9, 9.10
  - Unsuitability of cavity barriers 10.3
- Composite products**
- Materials of limited combustibility Appendix A(14)
- Concealed spaces (cavities)** 10.1–10.16
- Cavity walls excluded from provisions for cavity barriers Diagram 34
  - Definition Appendix E
  - Fire-resisting ceilings 7.6, Diagram 35
  - Maximum dimensions 10.8–10.12
  - Non-residential buildings Table 12
  - See also Cavity barriers
- Concourses**
- Floor space factors Table C1
- Conduits for cables**
- Openings passing through a separating element 10.16, 11.17
- Conference rooms**
- Floor space factors Table C1
- Conservatories**
- Measuring floor area Diagram C3
  - Plastic roofs Tables 17 and 18
- Construction (Health, Safety and Welfare) Regulations 1996** page 3
- Control rooms**
- Escape lighting Table 9
- Cooking facilities**
- See Kitchens
- Corridor access**
- Definition Appendix E
  - Escape routes Diagrams 7–9
  - Alternative exits 3.17
  - Vision panels in doors 6.17
- Corridors** 4.24–4.27
- Door opening 6.16
  - Escape lighting Table 9
  - Fire doors Table B1
  - Glazed screen to protected shafts 9.38, 9.39, Diagram 32
  - Subdivision 4.26, 4.27, Diagram 16
  - Cavity barriers 10.6
  - Dead ends Diagram 17
  - Uninsulated glazed elements on escape routes Table A4
  - Vision panels in doors 6.17
  - See also Bedroom corridors; Common corridors; Protected corridors
- Cover moulds**
- Definition of wall and ceiling 7.2, 7.3
- Crush halls**

## Index

- Floor space factors Table C1
- Cubic capacity**
  - Measurement Diagram C2
- Cupboards**
  - Fire doors Appendix B(2), Appendix B(8)
  - Protected stairways 5.38
- Curtain walls**
  - Elements of structure B3.iii
- D**
- Dance floors/halls**
  - Floor space factors Table C1
- Dead end**
  - Alternative means of escape B1.vii
  - Corridors 4.24, 4.27, Diagram 17
    - Fire door subdividing dead-end portions from remainder Table B1
    - Portion of 3.29
  - Definition Appendix E
  - Fire service vehicle access route 17.11, Diagram 50
  - Number of escape routes from flats 3.20
  - Travel distance Diagram 10
    - Uninsulated glazed elements on escape routes Table A4
  - Ventilation of escape routes from flats and maisonettes 3.26
- Deck access**
  - Means of escape from flats 3.22
- Different occupancies/uses**
  - See Mixed use; Separate occupancies
- Dining rooms**
  - Floor space factors Table C1
- Direct distances**
  - Definition Appendix E
  - Limitations on travel distance Table 2
- Disabled people** 0.17
  - Means of escape
    - Evacuation lifts B1.v, 6.39
    - Final exits 6.32
      - Ramps and sloping floors 6.28, 6.29
      - Travel distance limitations Table 2
    - Phased evacuation 5.26
    - Refuges for wheelchair users 5.7
    - Vision panels in doors 6.17
    - Warnings for hearing impaired people 1.34
      - See also Residential care homes
- Discounting of stairs** 5.3, 5.20, 5.21
  - Added protection 5.34
  - Tall buildings 5.27
- Discounting of storey exits** 4.21
- Domestic garages**
  - Fire doors between dwelling and garage Table B1
  - Measuring floor area Diagram C3
  - Smoke alarms 1.16
  - Wall and ceiling linings Table 10
- Doors and doorways**
  - Common escape routes Diagram 9
  - Definition of wall and ceiling 7.2, 7.3, 7.11
  - Direction of opening 6.14
  - Escape routes 6.10–6.18
  - Exit signs 6.37
  - External escape stairs 6.25
  - Fastening 6.11–6.13
  - Fire resistance 6.5, 6.6 Appendix B(1), Appendix B(11)
- Fire safety signs Appendix B(8) Fire service access 17.5
- Height of escape routes 4.17, 6.26
- Measuring width Appendix C(4), Diagram C1
- Openings in cavity barriers 10.16
  - Openings in compartment walls or floors 9.32–9.34
- Openings in enclosure to protected shaft 9.42
- Pressurized escape routes 4.27
- Separation of circulation routes from stairways 4.14
- Sub-division of corridors 4.26
- Vision panels 6.17
  - See also Automatic doors; Fire doors
- Dormitories**
  - Floor space factors Table C1
- Drainage**
  - Enclosure of pipes Diagram 38
  - Maximum nominal internal diameter of pipes 11.7, Table 14
- Dry mains**
  - See Fire mains
- Ducts**
  - Fire doors Appendix B(2), Appendix B(8)
  - Fire resistance tests Table A1
  - Openings in cavity barriers 10.16
  - Openings in compartment walls or floors 9.34
    - Containing flues or for appliance ventilation 11.16
  - Protected shafts 9.36
  - Protection of openings 11.9–11.14
  - Smoke vents 19.15
    - See also Flues
- Dwellings**
  - Definition Appendix E
  - See also Flats; Other residential use; Residential use
- E**
- Eaves**
  - Roof measurements Diagram C3
- Educational buildings** 0.24
  - Means of escape Table 2
  - Warnings for hearing impaired people 1.34
- Electrical circuits**
  - See Protected power circuits
- Electrically powered locks** 6.11
- Electrical wiring**
  - Concealed spaces 10.12
  - Fire-stopping 11.17
  - Openings passing through a separating element 10.16, 11.17
  - Protected circuits 6.38
  - Smoke alarms 1.19–1.22
    - See also Power supply
- Electricity generator rooms**
  - Escape lighting Table 9
    - See also Plant rooms
- Elements of structure**
  - Definition Appendix E
  - Fire resistance B3.iii, 8.2–8.10, Appendix A(5)
    - External walls 13.1
      - Tests by element Table A1
  - Emergency control rooms**
    - Escape lighting Table 9
  - Emergency egress windows**
    - See Windows
  - Emergency lighting** 6.36
    - Definition Appendix E
  - Emergency voice communication (EVC)** 5.11, 5.12
  - Enclosed car parks**
    - See Car parks
  - Enclosing rectangle**
    - Space separation 14.15
  - Enclosure**
    - Common stairs 3.36, 3.37
    - Corridors
      - Sub-division 4.26, Diagram 16
    - Drainage or water supply pipes Diagram 38
    - Escape stairs 5.32
    - Fire resistance 6.2–6.4
      - Tests Table A1
    - See also Protected escape routes
  - Enquiry office**
    - Protected stairways 5.38
  - Entrance halls**
    - See Protected entrance halls
  - Environmental protection** page 6
  - Escalators**
    - Escape routes in open spatial planning 4.12
    - Means of escape B1.vi
    - Protected shafts 9.36
      - Escape lighting** 6.36, Table 9
      - Definition Appendix E
      - Means of escape from live/work units 3.52
    - Escape routes**
      - Clear of building 6.31
      - Common parts of flats 3.19–3.31
      - Limitations on distance of travel Table 1
      - Small single stair building Diagram 9
      - Definition Appendix E Doors on 6.10–6.18
      - Fire doors Table B1
      - Floors 6.27
      - Height 4.17, 6.26
      - Helical stairs, spiral stairs and fixed ladders 6.22, 6.23
      - Horizontal escape 4.1–4.52, Table 2
      - Alternative routes Diagram 11
      - Minimum number Table 3
        - Width Table 4
      - Lifts prejudicing 6.40
      - Lighting 6.36, Table 9
      - Measuring width Appendix C(4)
      - Mechanical ventilation 6.46
      - Ramps and sloping floors 6.28, 6.29
      - Single steps 6.21
      - Siting access to refuse storage chambers 6.57
      - Siting of smoke vents 19.12
      - Small premises 4.32–4.37
        - Uninsulated glazed elements on escape routes Table A4
        - Width 4.18
        - Width relative to that of final exit 6.30
      - See also Protected escape routes
    - Escape stairs** 5.1–5.45
      - Added protection for phased evacuation 5.34
        - Alternative exits from flats 3.17
      - Capacity for basements and simultaneous evacuation 5.24, 5.25, Table 7
        - Construction 6.19, 6.20
      - Continuing beyond the level of final exit 6.33
        - Continuing down to basement 3.44–3.45
        - Door opening onto 6.16
        - Helical and spiral 6.22, 6.23



## Index

- Lift continuing down to basement 6.44
- Lighting 6.36, Table 9
- Measuring width Appendix C(4)
- Minimum width 5.15–5.17, 5.30, Table 6, Table 8
- Phased evacuation 5.30, 5.34, Table 8
- Travel distance Appendix C(3) Treads 6.27
- See also Protected stairways
- European Standards** pages 229–239
  - 12101
  - Part 2 Appendix C(5) 13501
    - Part 1 Appendix A(15) EN 54-11 1.31, 6.11
    - EN 81 18.13
    - EN 771
      - Part 1 Table A6
  - EN 1125 6.12
  - EN 1155 4.51
  - EN 1364 Appendix A(5) EN 1365 Appendix A(5) EN 1366 Appendix A(5)
    - Part 2 11.15
    - EN 1634 Appendix A(5), Appendix B(1)
      - Part 3 Table B1
        - EN 12101 3.27, 12.6
          - Part 3 19.14
          - Part 6 4.27, 5.21
      - EN 12845 2.4, 2.8
      - EN 13238 Appendix A(7) EN 13501
        - Part 1 B2.v, Appendix A(7)–A(9), Appendix A(11), Table A6, Table A7
        - Part 2 Appendix A(5), Appendix B(1)
          - Part 3 11.15, Appendix A(5) Part 4 Appendix A(5)
        - Part 5 15.4, Appendix A(6)
          - EN 13823 B2.v, Appendix A(7), Appendix A(9) EN 50200 6.38
          - EN ISO 1182 B2.v, Appendix A(7)–A(9)
          - EN ISO 1716 B2.v, Appendix A(7)–A(9)
          - EN ISO 11925
            - Part 2 B2.v, Appendix A(7)
      - European Technical Approval** page 4, Definition Appendix E
      - Evacuation**
        - Capacity of stairs for basements and for simultaneous evacuation 5.22–5.25, Table 7
        - Escape stairs 5.18–5.30
        - Purpose of providing structure with fire resistance 8.1
        - Relationships to security B1.xvii
        - Residential care homes 4.41–4.46
        - See also Escape routes; Phased evacuation; Progressive horizontal evacuation
      - Evacuation lifts** Definition Appendix E
        - Disabled B1.v, 5.10, 6.39
      - Exhaust points**
        - Mechanical ventilation and air conditioning systems 6.46
      - Exhibition halls** Floor space factors Table C1
      - Existing buildings**
        - Fire safety 0.19
        - See also Buildings of architectural or historical interest
      - Exit passageways**
        - Definition Appendix E
      - Exits**
        - Central cores 4.11, Diagram 13
        - Discounting of exits 4.21
        - Mechanical ventilation 6.46
        - See also Alternative exits; Final exits; Storey exits
        - Exit signs** 6.37
        - External assistance** B1.i
        - External escape** 3.17, 3.48, 3.49, 4.29, 4.30, 5.44, 5.45
        - External stairs 6.25
        - Fire resistance of adjacent areas
          - Diagram 25
          - Materials of limited combustibility 6.19
        - External fire spread**
          - External
            - Roof coverings 15.1 15.9
              - Roof coverings, Separation distances for roofs Table 16
            - External fire spread B4
              - Performance B4 guidance page 145
              - Requirement B4 page 144
        - External stairs** 6.25
        - External walls**
          - Concealed spaces 10.10
          - Construction 13.1–13.9
          - Definition Appendix E
          - Elements of structure B3.iii External escape stairs 6.25, Diagram 25
          - External fire spread B4.i
          - External surfaces 13.6, Diagram 40
          - Facing a boundary 14.4
          - Fire resistance 13.3
            - Tests Table A1
          - Fire resistance tests Table A2
          - Protected shafts 9.42
          - Protected stairways 3.41, 5.39, 6.24, Diagram 27
          - Unprotected areas 14.7–14.20, Diagram 43, Diagram 44
        - Extract ductwork**
          - Kitchens 11.10
      - F**
        - Factory production areas**
          - Floor space factors Table C1
          - Travel distance Table 2 note 6
          - See also Industrial purpose group
        - Fastenings**
          - Doors on escape routes 6.11–6.13
          - See also Security fastenings
        - Feature lifts**
          - Fire protection of lift installations 6.41
        - Final exits** B1.viii, 6.30–6.34
          - Definition Appendix E
          - Merging flows Diagram 15
          - Protected stairways 3.38, 5.36
          - Siting access to refuse storage chambers 6.57
        - Fire alarm systems**
          - Non-automatic 1.28
          - Phased evacuation 1.25, 5.26
          - See also Automatic fire detection and alarm system; Voice alarm systems
        - Fire dampers**
          - Definition Appendix E
          - Openings in cavity barriers 10.16
          - Ventilation ducts 6.47, 11.9–11.15
        - Fire detection**
          - See Automatic fire detection and alarm system
        - Fire doors** Appendix B(1)–B(12), Table B1
          - Definition Appendix E
          - See also Doors and doorways
        - Firefighting lifts** 18.1–18.5, 18.13
          - Approach 18.11, 18.14
          - Components of firefighting shaft
            - Diagram 52
          - Definition Appendix E
          - E Flats 18.14
        - Firefighting lobbies**
          - Approach to firefighting stair or lift 18.11, 18.14
          - Components of firefighting shaft
            - Diagram 52
          - Definition Appendix E
          - Firefighting facilities 18.1
          - Flats 18.14
          - Outlets from fire mains 16.5
        - Firefighting shafts** 5.32
          - Components Diagram 52
          - Definition Appendix E
          - Design and construction 18.11–18.13
          - External walls fire resistance 9.42
          - Fire resistance tests Table A1
          - Flats 18.1, 18.14
          - Provision 18.1–18.7, Diagram 51
            - Number and location 18.8–18.10
          - Provision of fire mains 16.2, 16.4, 18.12
        - Firefighting stairs** 3.35, 5.3, 5.38, 6.19
          - Approach through firefighting lobby area 18.11
          - Components of firefighting shaft
            - Diagram 52
          - Definition Appendix E
          - Outlets from fire mains 16.5
          - Protected stairways 5.38
          - Use as escape stairs 5.27
        - Fire hydrants** 16.7, 16.8
        - Fire load density** Appendix A(4)
        - Fire mains** 16.1–16.6
          - Firefighting shafts 16.2, 16.4, 17.6, 17.7, 18.12, Diagram 52
          - Implications for vehicle access 17.1, 17.6, 17.7
          - Provision of private hydrants 16.7
        - Fire penetration** B3.ii, Appendix A(5)
        - Fireplace surrounds**
          - Definition of wall 7.2
        - Fire propagation indices**
          - Internal linings Appendix A(11), Appendix A(12)
        - Fire resistance** Appendix A(3)–A(6)
          - Definition Appendix E
          - Discounting radiation through external walls 14.2
          - Elements of structure B3.iii, 8.2–8.10
            - Tests by element Table A1
          - Minimum periods by building type Table A2
          - Roofs Appendix A(6)
        - Fire-resisting construction** B1.ix, B3.iii, 8.2–8.10
          - Alternative escape routes 4.9
          - Ceilings 7.14, 7.16
            - Concealed spaces 7.6, 10.10, Diagram 35
            - Separation of bedrooms 10.7
          - Common stairs 3.34–3.42
          - Compartmentation 9.1, 9.20

## Index

- Corridors 4.24
  - Dead ends Diagram 17
  - Sub-division 4.26, Diagram 16
- Cupboards 5.38
- Definition Appendix E
- Doors and doorways Appendix B(11)
- Ducts 11.10
  - Openings in cavity barriers 10.16
- External escape stairs 6.25, Diagram 25
- Fire resistance tests Table A1
- Flat roof forming an escape route 6.35
- Lift installations 6.42
- Places of special fire hazard 9.12
- Refuse chutes and rooms for refuse storage 6.55
- Screens for sub-division of common escape routes 3.29, 4.26
- Shop store rooms 6.58
- Smoke outlet shafts 19.15, 19.16, Diagram 53
- Ventilation ducts 6.48
- Fire safety**
  - Alternative approaches 0.19
- Fire safety engineering** 0.28–0.32
- Fire safety information** 0.12
- Fire Safety Order** page 2
- Fire safety signs**
  - Exits 6.37
  - Fire doors Appendix B(8)
- Fire-separating elements** B3.iii
  - Definition Appendix E
  - See also Fire stops
- Fire separation**
  - Adjoining protected stairways 3.39, 5.37
  - Between buildings 0.31, 9.1, 9.21
    - Enclosure to protected shaft 9.42
    - External walls B4.i, 14.6
  - Compartmentation 9.22
  - Fire resistance B3.ii, B3.iii
  - Openings 11.1, 11.2
    - Compartment walls 9.32, 9.34
  - Open sided car parks 12.3
  - See also Cavity barriers; Compartments
- Fire service facilities** B5.i–00.ii, 0.31
  - Access to buildings for firefighting personnel 18.1–18.14
  - Buildings not fitted with fire mains 17.2–17.5
  - Building footprint and perimeter Diagram 48
  - Fire mains 16.1–16.6
  - Performance B5 guidance page 164
  - Requirement B5 page 163
  - Vehicle access 17.1
    - Access routes and hard-standings 17.8–17.11, Table 20
  - Blocks of flats 17.3
  - Buildings fitted with fire mains 17.6, 17.7
  - Buildings not fitted with fire mains 17.2–17.5, Table 19
  - High reach fire appliance access to buildings Diagram 49
  - Turning facilities 17.11, Diagram 50
- Fire severity** 0.30
- Fire spread**
  - See External fire spread; Internal fire spread
- Fire stops** 11.2, 11.17–11.19
  - Definition Appendix E
- Junction of compartment wall or floor with other walls 9.25
- Junction of compartment wall with roof 9.28, Diagram 30
- Junction with slates, tiles, corrugated sheeting or similar 10.14
- Pipe openings 11.7
- Reinforcing materials 11.18, Table A7
- Fire suppression**
  - Active measures 0.31
  - See also Sprinkler systems
- Fire tests**
  - Fire resistance by element of structure, etc. Table A1
  - Methods B2.v, 0.7, Appendix A(1)–A(21)
- Fittings**
  - Fire spread B2.iv
  - See also Ladders
- Fixed seating** 6.29
  - Calculation of travel distance Appendix C(3) Spacing 4.20
- Fixings**
  - Cavity barriers 10.15
- Flame spread**
  - See External fire spread; Internal fire spread
- Flat roofs**
  - Means of escape 4.31, 6.35
  - Flats 3.7, 3.17, 3.31
  - Measuring height Diagram C4
  - Notional designations of coverings Table A5
- Flats**
  - Acceptable unprotected area 14.15, 14.19, 14.20, Diagram 46
  - Ancillary use Appendix D(3)
  - Compartmentation 9.13, 9.14
  - Conversion to 8.9, 8.10
  - Fire detection and alarm systems 1.3–1.18
  - Fire doors Appendix B(9), Table B1
  - Fire service facilities 18.1
  - Firefighting shafts 18.14
  - Vehicle access 17.3
  - Means of escape 3.1–3.52
    - In common areas of building 3.19–3.48
  - Distance of travel in common areas Table 1
  - From each unit 3.5–3.18
  - Internal planning 3.10–3.16, Diagrams 2–9
  - Served by more than one common stair Diagram 8
    - Served by one common stair Diagram 7
  - Small single stair building Diagram 9
  - Purpose groups Table D1
  - Uninsulated glazed elements on escape routes Table A4
- Flexible membranes** 7.8
- Floor area**
  - Methods of measurement Diagram C3
- Floor level**
  - Change in relation to door swing 6.15
  - Single step on escape routes 6.21
- Floors**
  - Concealed spaces 10.10
  - Elements of structure B3.iii, 8.4
  - Escape routes 6.27
  - Flats more than 4.5m above ground level 3.13–3.18
- Fire resistance 8.2
  - Tests Table A1
- Fire spread by upper surfaces B2.ii
- Sloping 6.28
  - See also Compartment floors
- Floor space factors** Appendix C(2), Table C1
- Flues**
  - Fire resistance tests Table A1
  - Non-combustible materials Table A6
  - Openings in compartment walls or floors 9.34, 11.16, Diagram 39
- Foundations**
  - Steel portal frames 13.4
- Fuel storage space**
  - Common stairs 3.46
  - Mixed use occupancy 3.51
  - See also Places of special fire hazard
- Fully supported material**
  - Designation of roof coverings Table A5
- Furnishings**
  - Fire spread B1.iii
- Furniture**
  - Fire spread B2.iv
  - Fitted – Definition of wall 7.2
- Fusible links**
  - Holding open self-closing fire doors Appendix B(3)
- G**
- Galleries**
  - Counting storeys Diagram C5
  - Definition Appendix E
  - Fire resistance 8.2
    - Tests Table A2
  - Means of escape 3.5, 3.8, Diagram 1
  - Raised storage areas 8.7
- Gangways**
  - Calculation of travel distance Appendix C(3)
  - Fixed seating 6.29
  - Between fixed storage racking Table 4
- Garages**
  - See Car parks; Domestic garages
- Gas appliances**
  - Protected stairways 5.38
- Gas meters**
  - Protected stairways 3.42, 5.40
- Gas service pipes**
  - Protected shafts 9.40
  - Protected stairways 3.42, 5.40
  - Ventilation 9.41
- Glazed screens**
  - Construction of protected shafts 9.37, 9.38, Diagram 32
  - Use on escape routes Table A4
- Glazing**
  - Definition of wall and ceiling 7.2, 7.3
  - In door not part of wall 7.11
  - External escape stairs 6.25
  - Fire resistance of glazed elements 6.6–6.9
- Glass and glazing elements on escape routes 6.4, Table A4
- Limitations on areas of uninsulated glazing Table A4
- Partitions 4.36
- Protected shafts 9.37
- Safety 6.9
- Thermoplastic materials 7.11
- Unwired glass in rooflights 15.8
- Gradient**

## Index

Hard-standings Diagram 49  
**Group homes for mentally impaired/mentally ill** 0.22  
**Guarding**  
Flat roof forming escape route 6.35  
Route clear of the building 6.31

## H

**Habitable rooms**  
Definition Appendix E  
**Hammerhead**  
Fire service vehicle access route 17.11  
**Handicapped**  
See Disabled people  
**Handrails**  
Width of escape stairs 5.15, 5.16, Appendix C(4)  
**Hardstandings**  
Firefighting vehicles 17.8–17.10, Diagram 49  
**Hardware**  
Fire doors Appendix B(12)  
See also Fastenings  
**Hazard**  
See Places of special fire hazard; Risk  
**Headroom**  
Escape routes 6.26  
Horizontal escape 4.17  
**Health and safety**  
Limitation on requirements page 1  
**Health care premises** 0.21  
Compartmentation 9.15, 9.16  
Escape travel distances Table 2  
See also Residential (institutional) purpose; Residential care homes  
**Heat alarms**  
See Automatic fire detection and alarm system  
**Heating systems**  
Air circulation systems in flats 3.18  
See also Air conditioning  
**Heat transfer**  
Insulation from high temperatures B3.ii, Appendix A(5) Radiation  
Basis for calculating acceptable unprotected area 14.16  
Discounting 14.2  
**Height**  
Definition Appendix E  
Methods of measurement of building Diagram C4  
of top storey Diagram C6  
**Helical stairs**  
Escape routes 6.22, 6.23  
**High reach appliances**  
Firefighting vehicle access 17.1  
Access route specification Diagram 49, Table 20  
Buildings not fitted with fire mains Table 19  
Overhead obstructions 17.10, Diagram 49  
**High risk**  
See Places of special fire hazard  
**Hinges**  
Fire doors Appendix B(7)  
**Historic buildings** 0.33  
**Homes**  
See Group Homes for mentally impaired/mentally ill; Residential (institutional) purpose; Residential care homes  
**Horizontal escape** 4.1–4.52  
**Residential care homes 4.38–4.52**  
Small premises 4.32–4.37, Diagram 18  
**Hoses**  
Fire mains 16.1

**Hospitals** 0.21  
Escape travel distance Table 2  
See also Health care premises  
**Hotels**  
Ventilation ducts 11.13  
Warnings for hearing impaired people 1.34  
See also Other residential use  
**House conversions**  
Conversion to flats 8.9, 8.10  
**Houses in multiple occupation** page 3  
**Hydraulic lifts**  
Pipes for oil or gas in protected shafts 9.40  
**Hydraulic platforms**  
See High reach appliances

## I

**Ignition susceptibility**  
External walls 13.2  
**Industrial purpose group**  
Compartmentation 9.18, 9.19  
Escape routes  
Lighting Table 9  
Single escape stairs 5.6  
Travel distance limitations Table 2  
Maximum dimensions of building or compartment Table 12  
Minimum periods of fire resistance Table A2  
Purpose groups Table D1  
Space separation  
Acceptable unprotected area 14.20  
Acceptable unprotected areas 14.16  
Permitted unprotected areas in small buildings or compartments Table 15  
Roofs Diagram 47, Table 17  
ground storey 9.19  
See also Storage and other non-residential  
**Information**  
Fire safety 0.12  
**Inner rooms**  
Definition Appendix E  
Escape from flats 3.5  
Horizontal escape 4.10, 4.15, Diagram 12  
**In-patient care**  
See Hospitals; Residential care homes  
**Inspection covers**  
Design of access routes and hard-standings 17.8  
**Installers**  
Certification and accreditation 0.16, 1.23, 1.37  
**Institutional premises**  
See Residential (institutional) purpose  
**Insulated roof sheeting**  
Concealed spaces 10.10  
Cavity barriers 10.5, Diagram 36  
Junction of compartment wall with roof 9.29  
**Insulating core panels** Appendix F  
**Insulation**  
Above fire-protecting suspended ceilings Table A3, Table A7  
Concealed spaces  
Flame spread rating of pipe insulation 10.12  
Space containing combustible insulation 10.10  
External wall construction 13.7  
High temperatures B3.ii, Appendix A(5)  
**Integrity**  
Compartment walls 9.27  
Resistance to collapse B3.ii, Appendix A(5)  
Resistance to fire penetration B3.ii,

Appendix A(5)  
**Intercom system**  
Phased evacuation 5.29  
**Internal fire spread**  
Car parks 12.2–12.6  
Circulation spaces B1.iii  
Fittings B2.iv  
Floor upper surfaces B2.ii  
Furnishings B1.iii  
Furniture B2.iv  
Implications for means of escape B1.iii  
Linings page 98, B2.i, Appendix A(10)–A(13), Appendix A(16) Performance B2 guidance page 98  
Requirement B2 page 97  
Noxious gases B1.iv  
Shopping complexes 12.7, 12.8  
Smoke and fumes B1.iv  
Lining materials B2.i  
Retarding by sealing or fire-stopping 11.3  
Stair upper surfaces B2.ii  
Structure  
Performance B3 guidance page 107  
Requirement B3 page 106  
**Internal linings**  
Classification 7.1–7.16, Table 10  
Performance of materials Appendix A(10)–A(16)  
Protection of substrate Appendix A(18)

## J

**Joists**  
Timber, in compartment walls 8.20  
**Junctions**  
Cavity barriers 10.3  
Compartmentation 9.6  
Compartment wall or floor with other walls 9.25–9.27  
Compartment wall with roof 9.28–9.31, Diagram 30

## K

**Keys**  
See Security fastenings  
**Kitchens**  
Extract ductwork 11.10  
Fire protection of lift installations 6.43  
Floor space factors Table C1  
Galleries in flats 3.8  
Means of escape from flats 3.13, Diagram 3  
Small premises 4.33  
Smoke alarms 1.16  
Positioning 1.9, 1.12

## L

**Ladders**  
Means of escape B1.vi, 6.22, 6.23  
Flats 3.3  
Non-combustible materials Table A6  
See also High reach appliances  
**Landings**  
Door opening and effect on escape routes 6.15  
Fire doors Appendix B(9)  
Fire resistance of areas adjacent to external stairs Diagram 25  
Floorings 6.27  
See also Protected landings

## Index

### Large and complex buildings

Fire safety engineering 0.28–0.32

Fire safety information 0.12

Mixture of uses Appendix D(5)

Protected power circuits 6.38

### Latches

See Fastenings

### Libraries

Floor space factors Table C1

### Lifts

Exits in central core 4.11

Fire doors Appendix B(1),

Appendix B(9)

Forming part of enclosure of lift

shaft Table B1

Fire protection of installations

6.40–6.45

Protected shafts 9.36

Containing pipes 9.40

Openings in enclosure 9.42

Unacceptable means of escape B1.vi

Use of space within protected

stairways 3.40, 5.38

See also Evacuation lifts;

Firefighting lifts

### Lighting

Escape routes 6.36, Table 9

### Lighting bridges

See Galleries

### Lighting diffusers

Suspended ceilings 7.10, 7.13–7.15,

Appendix A(19), Diagram 26,

Table 11

Thermoplastic 7.15

Layout restrictions Diagram 27

Use of space below Table 11

Limitations on requirements page 1

### Limited combustibility

See Materials of limited combustibility

### Linings

See Internal linings

### Live/work units

Definition Appendix E

Means of escape 3.52

### Living rooms

Positioning smoke alarms 1.9

### Loadbearing capacity

Appendix

A(5) Compartment walls 9.27

Deflection of compartment walls 9.27

Resistance to collapse B3.ii

### Loadbearing elements of structure

See Elements of structure

### Lobbies

Common escape route in small single

stair building Diagram 9

Exit capacity 4.23

Exits in central core 4.11

Glazed screen to protected shafts

9.38, 9.39, Diagram 32

Use of uninsulated glazed

elements on escape routes Table

A4

Ventilation of common

escape routes 3.25

See also Firefighting

lobbies; Protected lobbies

### Locks

See Fastenings

### Lounges

Fire protection of lift installations 6.43

Floor space factors Table C1

## M

### Maintenance

Fire safety 0.12, 0.14

Smoke alarms 1.15, 1.18

### Main use

Purpose groups Appendix D(1)

### Maisonettes

See Flats

### Malls

Application of requirements 12.7

Escape travel distances in

shopping malls Table 2

Fire protection of lift installations 6.41

Floor space factors in shopping malls

Table C1

### Management

Premises 0.14

See also Central alarm monitoring

### Mantleshelves

Definition of wall 7.2

Material alteration 0.18

Fire detection and alarm systems 1.6

### Materials and workmanship

Regulation 7 page 2

### Materials of limited combustibility

Class 0 Appendix A(13)

Composite products Appendix

A(14) Concealed spaces 10.12

Construction of escape stairs 6.19

Definition Appendix E

Insulation above fire-

protecting

suspended ceilings Table A3

Insulation materials used in

external wall construction 13.7

Junction of compartment wall

with roof 9.29, Diagram 30

Performance Appendix A(9)

Reinforcing materials used

for

fire-stopping 11.18

Roofs Table 17

Use Table A7

### Means of escape

Criteria B1.v–B1.vi

Definition Appendix

E Flats 3.1–3.52

Escape from each unit 3.5–3.18

Escape in common areas 3.19–3.48

Internal planning Diagrams 2–9

Openings in compartment walls 9.32

Openings into protected shafts 9.42

Performance B1 guidance page 17

Requirement B1 page 16

See also Escape routes

### Measurement methods

Appendix

### C Mechanical ventilation

See Ventilation

### Mechanised walkways

Means of escape B1.vi

### Meeting rooms

Floor space factors Table C1

### Mixed use

Car park and other use 12.3

Compartment walls and compartment

floors 9.11

Division of storeys 4.15

Dwellings in mixed use buildings

3.50–3.51

Interpretation of purpose groups

Appendix D(3)–(5)

Means of escape

Escape routes 4.4

Escape stairs 5.3

Horizontal escape 4.1

Storage of petrol and LPG 3.51

### Multiple occupation

page 3

### Multi-storey buildings

Compartments 9.27

Horizontal escape 4.3

Vertical escape from buildings other

than dwellings 5.1–5.45

See also Tall buildings

## N

### Natural ventilation

See Ventilation

### Non-combustible materials

Definition Appendix E

Performance Appendix A(8)

Sleeving non-combustible pipes 11.8

Use Table A6

### Non-residential buildings

Acceptable unprotected area 14.20

Calculating acceptable unprotected

area Table 15

Compartmentation 9.18

Maximum dimensions of building or

compartment Table 12

Maximum dimensions of concealed

spaces Table 13

Purpose groups Table D1

Wall and ceiling linings 7.4, Table 10

Notional boundaries 14.6,

Diagram 42

Definition Appendix E

Separation distances for roofs 15.5

### Noxious gases

Fire spread B1.iv

## O

### Occupancies

See Mixed use; Separate occupancies

### Occupancy type

Definition Appendix E

### Occupant capacity

Calculation

Appendix C(2) Horizontal escape

4.5, 4.8, 4.10,

4.19, 4.21–4.23, Diagram 15

Residential care homes 4.45, 4.46

Small premises 4.33

Width of escape stairs 5.18, 5.19,

5.24, 5.25, 5.30, Table 6

### Offices

Compartmentation 9.18

Escape lighting Table 9

Floor space factors Table C1

Junction of compartment wall with

roof 9.30

Maximum dimensions of building or

compartment Table 12

Means of escape

Alternative approach 4.1

Fire doors Table B1

Limitation of travel distance Table 2

Single escape stairs 5.6

Small premises 4.1

Minimum periods of fire resistance

Table A2

Over shops Appendix D(4)

Purpose groups Table D1

Space separation

Acceptable unprotected areas

14.16, 14.20, Table 15

Warnings for hearing impaired

people 1.34

### Openable vents

Escape routes for flats 3.26,

Diagrams 7–9

### Openable windows

See Windows

### Opening characteristics

Doors and doorways 6.14–6.16

### Openings

Cavity barriers 10.3, 10.16

Compartment walls or floors 9.34

Compartment walls separating

buildings or occupancies 9.32

Escape routes in open spatial

planning 4.12, Diagram 14

## Index

- Protected shafts 9.42
- Protection 11.1, 11.2
- See also Doors and doorways; Windows
- Open-sided car parks**
- See Car parks
- Open spatial planning**
- Awareness of fires 4.25
- Definition Appendix E
- Escape lighting Table 9
- Escape routes 4.12, Diagram 14
- Fire protection of lift installations 6.41
- Simultaneous evacuation 5.23
- Other non-residential**
- See Storage and other non-residential
- Other residential use** 1.35
- Acceptable unprotected area 14.15, 14.16, 14.19, 14.20, Diagram 46
- Calculating acceptable unprotected area Table 15
- Compartmentation 9.17
- Fire doors Appendix B(9), Table B1
- Junction of compartment wall with roof 9.30
- Limitations on travel distance Table 2
- Minimum periods of fire resistance Table A2
- Partitions and provision of cavity barriers 10.7
- Purpose groups Table D1
- Simultaneous evacuation 5.23
- Outbuildings**
- Measuring floor area Diagram C3
- Overhanging storey**
- See Perimeter of building
- Overhead obstructions**
- Access for high reach appliances 17.10, Diagram 49
- P**
- Partitions**
- Cavity barriers 10.13
  - Separation of bedrooms 10.7
- Enclosing corridors 4.25
- Fire resistance 6.3
- Glazing 4.36
- See also Walls
- Pavement lights**
- Smoke vent outlet terminal 19.11
- Performance**
- Access and facilities for fire service B5 page 164
- External fire spread B4 page 145
- Internal fire spread
- Linings B2 page 98
- Structure B3 page 107
- Materials and structures Appendix A(1)–A(21)
- Means of escape B1 page 17
- Ratings of some generic materials and products Table A8
- Perimeter of building**
- Definition Appendix E
- Example of footprint and perimeter Diagram 48
- Fire service vehicle access Table 20
- Phased evacuation**
- Alarm systems 1.25, 5.26, 5.29
- Disabled people 5.26
- Escape stairs
  - Added protection 5.34
  - Minimum width 5.30, Table 8
- Internal speech communication system 5.29
- Protected escape routes 5.29
- Tall buildings 5.26, 5.27
- Picture rails**
- Definition of wall and ceiling 7.2, 7.3
- Pipes**
- Cavity barriers 10.16
- Compartment walls or floors 9.32, 9.34
- Maximum nominal internal diameter 11.7, Table 14
- Definition Appendix E
- Flame spread rating of insulation
- Maximum dimensions of concealed spaces 10.12
- Non-combustible materials Table A6
- Openings 11.5–11.8, 11.17
- Penetrating structure Diagram 37
- Protected shafts 9.36
  - Oil or gas 9.40
  - Openings 9.42
- See also Gas service pipes
- Pitched roofs**
- Measuring height Diagram C4
- Notional designations of coverings Table A5
- Place of safety**
- Inside building B1.v
- Places of special fire hazard**
- Common stairs 3.47
- Compartmentation 9.12
- Definition Appendix E
- Escape stairs 5.35
- Fuel storage space
- Common stairs 3.46
  - Mixed use occupancy 3.51
- High risk and lift installations 6.43
- Inner rooms 4.10
- Limitations on travel distance Table 2
- Small premises 4.32
- Smoke vents 19.9
- Plant rooms**
- Fixed ladders 6.22
- Limitations on travel distance Table 2
- See also Boiler rooms; Places of special fire hazard
- Plastics**
- Rooflights 7.7, 15.4, 15.6, 15.7, Table 11
- Layout restrictions Diagram 27
  - Limitations on use and boundary distance Tables 17 and 18
- Spacing and size Diagram 47
- See also Thermoplastic materials
- Platform floors**
- Definition Appendix E
- Exclusions from elements of structure 8.4
- Plenum**
- Maximum dimensions of concealed spaces 10.12
- Podium**
- External escape stairs 3.49
- Fire resistance of adjacent areas Diagram 25
- Polycarbonate sheet**
- TP(a) rigid and TP(b) Appendix A(20)
- Porches**
- Smoke alarms 1.17
- Portal frames** 13.4
- Power supply**
- Mechanical ventilation for car parks 12.6
- Protected power circuits 6.38
- Smoke and heat alarms 1.5, 1.19–1.22
- Pressurization**
- Compatibility with ventilation and air conditioning 6.52
- Corridors 4.27
- Ducts in protected shafts 9.40
- Smoke control 3.27
  - Private hydrants** 16.7, 16.8
- Progressive horizontal evacuation**
- Residential care homes 4.41–4.46, Diagram 19
- Projecting upper storey**
- See Overhead obstructions
- Property protection** 0.15
- Protected circuits** 6.38
- Definition Appendix E
- Protected corridors** 4.24
- Added protection for escape stairs 5.34
- Dead-end corridors Diagram 17
- Definition Appendix E
- Escape routes for flats
- Ancillary accommodation 3.30
- Basements 3.45
- Common corridors 3.24
- Fire doors Table B1
- Fire resistance tests Table A1
- Phased evacuation 5.29
- Refuges for wheelchair users 5.8, 5.9
- Storeys divided into different occupancies 4.16
- Uninsulated glazed elements on escape routes Table A4
- Protected entrance halls**
- Definition Appendix E
- Escape from flats 3.13, 3.17, 3.18, Diagram 2, Diagram 6
- Fire doors Table B1
- Protected escape routes**
- B1.viii–00.ix
- Cavity barriers 10.4
- Corridors 4.24
  - Dead ends Diagram 17
- Discounting of stairs 5.21
- Escape stair needing added protection 5.34
- Fire resistance 6.2–6.9
- Phased evacuation 5.29
- Protection and compartmentation 9.1
- Storeys divided into different occupancies 4.16
- Ventilation 6.47, 6.48
- Protected landings**
- Definition Appendix E
- Flats Diagram 6
  - Alternative exits 3.16
- Fire doors Table B1
- Protected lobbies**
- Ancillary accommodation 3.30, 3.47
- Common escape routes 3.23
- Definition Appendix E
- Discounting of stairs 5.21
- Escape stairs 5.34, 5.35
- Fire doors Table B1
- Fire protection of lift installations 6.42, 6.43
- Fire resistance tests Table A1
- Number of escape routes 3.20
- Phased evacuation 5.29
- Refuges for wheelchair users 5.8, 5.9
- Refuse chutes and rooms for refuse storage 6.55, 6.56
- Storey exits 4.13
- Uninsulated glazed elements on escape routes Table A4
- Ventilation 6.56
- Protected power circuits**
- 6.38
- Definition Appendix E
- Protected shafts** 5.32, 9.7, 9.35–9.42, Diagram 31
- Definition Appendix E
- External wall of stairs in 14.8, Diagram 44

## Index

- Fire doors Table B1
- Fire resistance tests Table A1
- Glazed screens 9.38, 9.39, Diagram 32
- Lift installations 6.42
- Openings 9.42
- Pipes in 11.5
  - Oil or gas 9.40
- Pipes passing through structure enclosing protected shaft Table 14
- Ventilating ducts 9.40
- Ventilation of shafts conveying gas 9.41
- See also Firefighting shafts
- Protected stairways**
  - B1.ix
- Air circulation systems for flats 3.18
- Common stairs 3.34–3.42
- Definition Appendix E
- Escape routes
- From common parts of flats 3.34–3.42
  - From each unit 3.16
- Escape stairs 5.1–5.45
- Exits in central core Diagram 13
- External protection Diagram 24
- Fire doors Table B1
- Fire protection of lift installations 6.42, 6.45
- Fire resistance tests Table A1
- Protected shafts 9.35, 9.36
  - Containing pipes 9.40
  - Unprotected areas 14.8
- Refuges for wheelchair users 5.7–5.9, Diagram 21
- Refuse chutes and rooms for refuse storage 6.55
- Rooflights of thermoplastic materials 7.12
- Separation of circulation routes from stairways 4.14
- Thermoplastic lighting diffusers in ceilings 7.15
- Uninsulated glazed elements on escape routes Table A4
- Use of space below diffusers or rooflight Table 11
- Ventilation 6.47
- Vertical escape 5.31–5.40
- Protective barriers**
- Flat roof forming escape route 6.35
- PTFE-based materials**
  - 7.9
- Public address system**
  - 1.33
- Publications (excluding BSI and European Standards)**
- Approved Document
  - F Ventilation 12.5, 12.6
- J Combustion appliances and fuel storage 15.9, Diagram 39
- K Protection from falling, collision and impact 3.9, 5.16, 6.20, 6.23, 6.29, 6.35
- M Access and facilities for disabled people 4.18, 6.17, 6.28, 6.29, Tables 4 and 6
- N Glazing – safety in relation to impact, opening and cleaning 6.9, 6.17, 7.11
- Building regulation and fire safety – Procedural Guidance page 3
- CE Marking Directive page 4
- Code of practice for fire-resisting metal doorsets. DSMA Appendix B(11)
- Construction fire safety. CIS 51 page 4
- Crown Fire Standards 0.15
  - fire management of insulated envelopes for temperature controlled environments. IACSC Appendix F(8)
- Designing for structural steel safety: a handbook for architects and engineers. SCI P197 Appendix A(1)
- Design methodologies for smoke and heat exhaust ventilation. BRE Table 2
- Ensuring best practice for passive fire protection in buildings. ASFP 10.19
- External fire spread: building separation and boundary distances. BRE 14.15, 14.16, 14.20
- Fire and smoke resisting dampers. ASFP Grey Book 11.14
- Firecode. DoH 0.21, Table 2
- Fire performance of external thermal insulation for walls of multi storey buildings. BRE 13.5
- Fire protection for structural steel in buildings. ASFP Appendix A(5)
- Fire resisting ductwork. ASFP Blue Book 11.10
- Fire safe design: a new approach to multi storey steel-framed buildings. SCI 288 9.27
- Fire safety in construction work, HSG 168 page 4
- Fire safety of PTFE-based materials used in buildings. BRE 7.9
- Fire stopping and penetration seals for the construction industry. ASFP Red Book 11.19
- FPA Design guide for the fire protection of buildings. 0.15
- Gas Safety (Installation and Use) Regulations 1998 3.42, 9.40
- Guidance in support of functional provisions for healthcare premises. HTM 05-02 0.21
- Guidelines for the construction of fire-resisting structural elements. BRE Appendix A(1)
- Guide to fire precautions in NHS housing in the community for mentally handicapped (or mentally ill) people. HTM 88 0.22
- Guide to safety at sports grounds 0.24
- Hardware for fire and escape doors. ABHM Appendix B(12)
- Health & Safety (Safety signs & signals) Regulations 1996.
- Guidance on Regulations 6.37
- Housing health and safety rating system operating guidance page 3
- Increasing the fire resistance of existing timber floors. BRE Digest 208 Table A1
- Managing fire water and major spillages. EA PPG18 page 6
- Multi-storey timber frame buildings: a design guide. BRE 454 Appendix A(1)
- Pipelines Safety Regulations 1996 3.42, 9.40
- Single-storey steel framed buildings in fire boundary conditions. SCI P313 13.4
- Sprinklers for safety: use and benefits of incorporating sprinklers in buildings and structures. BAFSA 2.3
- Thatched buildings. New properties and extensions 15.9
- Timber fire-resisting doorsets: maintaining performance under the new European test standard. TRADA. Appendix B(11)
- Workplace (Health, Safety and Welfare) Regulations 1992, Approved Code of Practice and Guidance page 3
- Pumping appliances**
- Dry fire mains 17.6
- Firefighting vehicle access 17.1
- Access route specification Table 21
- Blocks of flats 17.3
- Buildings not fitted with fire mains Table 19
- Replenishing wet fire mains 16.1, 17.7
- Purpose groups** Appendix D Classification Table D1
- Definition Appendix E
- Fire safety 0.10
- PVC sheet**
- TP(a) rigid Appendix A(20)
- Q**
- Quantitative techniques**
- Risk and hazard evaluation 0.32
- Queueing areas**
- Floor space factors Table C1
- R**
- Racking**
- See Storage and other non-residential
- Radiation**
- See Heat transfer
- Rafters**
- Portal frames 13.4
- Timber, in compartment walls 9.20
- Raised storage**
- Fire resistance 8.7, 8.8
- See also Storage and other non-residential
- Ramps**
- Escape routes 6.28, 6.29
- Reading rooms**
- Floor space factors Table C1
- Reception desk**
- Protected stairways 5.38
- Recirculating air distribution systems**
- Maximum dimensions of concealed spaces 10.12
- Mechanical ventilation 6.49
- See also Air conditioning
- Recreation**
- See Assembly and recreation purpose group
- Refuges**
- Means of escape for disabled 5.7–5.14, Diagrams 20 and 21
- Refuse chutes** 6.54–6.57
- Non-combustible materials Table A6
- Openings in compartment walls or floors 9.34
- Protected shafts 9.36
- Refuse hoppers** 6.54
- Refuse storage chambers**
- Access 6.57
- Compartment walls 9.14
- Location of final exits 6.34
- Regulatory Reform (Fire Safety) Order 2005** page 2

## Index

- Relevant boundaries** 13.1, 14.4, 14.5, Diagram 41  
 Acceptable unprotected areas 14.19, 14.20  
 Definition Appendix E  
 External walls 1000mm or more from relevant boundary 14.14  
 External walls within 1000mm from relevant boundary 14.13  
 Portal frame building near boundary 13.4  
 Separation distances for roof 15.5, Table 16
- Residential care homes**  
 Ancillary accommodation  
 Escape routes 4.44  
 Automatic fire detection and alarm system 4.47  
 Automatic self-closing devices 4.51  
 Bedrooms 4.48, 4.49  
 Horizontal escape 4.38–4.52  
 Occupant capacity 4.45, 4.46  
 Travel distance 4.43  
 Progressive horizontal evacuation 4.41–4.46, Diagram 19  
 Sprinkler systems 4.52
- Residential (institutional) purpose** 1.35  
 Compartmentation 9.15–9.16  
 Means of escape  
 Care homes 4.38–4.52, Diagram 19  
 External escape stairs 5.44  
     Inner rooms 4.10  
 Limitations on travel distance Table 2  
 Single escape routes and exits 4.5  
 Minimum periods of fire resistance Table A2  
 Minimum width of escape stairs Table 6  
 Partitions and provision of cavity barriers 10.7  
 Purpose groups Table D1  
 Use of uninsulated glazed elements on escape routes Table A4  
 Ventilation ducts 11.13
- Residential use**  
 Buildings other than flats 1.25  
 Escape lighting Table 9  
 Escape routes 4.1, 4.4  
     Protected corridors 4.24  
 Mixed use 3.50, 3.51, 5.4  
 Purpose groups Table D1  
 Space separation 14.2  
 Notional boundaries 14.6  
 Permitted unprotected areas 14.16, 14.19, 14.20, Diagram 46, Table 15  
 Wall and ceiling linings 7.4, Table 10  
 See also Flats;  
 Other residential use; Residential (institutional) purpose
- Restaurants**  
 Escape lighting Table 9  
 Floor space factors Table C1
- Revolving doors**  
 Escape routes 6.18
- Rising fire mains**  
 See Fire mains
- Risk**  
 Assessment page 2, B1.ii  
 Insurance 0.15  
 Quantitative techniques of evaluation 0.32  
 See also Places of special fire hazard
- Rolling shutters** 18.15, Appendix (2), Appendix B(6)
- Roof coverings**  
 Concealed spaces between insulated roof sheeting 10.10  
     Cavity barriers Diagram 36  
 External fire spread 15.1–15.9  
     Separation distances for roofs Table 17  
         Junction of compartment wall with roof 9.28–9.31, Diagram 30  
 Materials of limited combustibility Table A7  
 Notional designations Table A5
- Rooflights**  
 Definition Appendix E  
 Definition of ceiling 7.3  
 Methods of measurement Diagram C3  
 Plastic 7.7, 7.12, 15.4, 15.6, 15.7, Appendix A(19), Table 11  
 Junction of compartment wall with roof 9.29  
 Limitations on spacing and size Diagram 27, Diagram 47  
     Limitations on use and boundary distance Tables 17 and 18  
 Unwired glass 15.8  
 Use of space below Table 11
- Roofs**  
 Concealed spaces between insulated roof sheeting 10.10  
     Cavity barriers Diagram 36  
 Elements of structure B3.iii, 8.4  
 Escape over 3.31, 4.31, 6.35  
 External escape stairs 3.49  
 Fire resistance of adjacent areas Diagram 25  
 Fire resistance 6.3, Appendix A(6)  
     Junction of compartment wall with roof 9.28–9.31, Diagram 30  
 Materials of limited combustibility Table A7  
 Measuring area Diagram C3  
     height Diagram C4  
 Rooftop plant  
     Height of top storey in building Diagram C6  
     Limitations on travel distance Table 2  
 Space separation 14.1, 15.5  
 See also Flat roofs; Pitched roofs
- Roof space**  
 Cavity barriers 10.8, 10.10  
 Concealed space 10.1
- Rooms**  
 Definition Appendix E  
 Measuring floor area Diagram C3
- S**
- Sanitary accommodation**  
 Protected shafts 9.36  
 Protected stairways 5.38
- Sanitary towel incinerators**  
 Protected stairways 5.38
- Schools** 0.24  
 Definition Appendix E  
 See also Educational buildings
- Seals**  
 Fire resistance 11.2  
 Proprietary seals 11.19  
 Pipes 11.6
- Seating**  
 See Fixed seating
- Security**  
 Conflict with requirements for means of escape B1.x  
 See also Access control
- Security fastenings**  
 Common escape routes Diagram 9
- Doors on escape routes 6.11, 6.12
- Self-closing devices**  
 See Automatic self-closing devices
- Self-supporting sheets**  
 Designation of pitched roof coverings Table A5
- Separated parts of buildings** 9.22  
 Definition Appendix E
- Separate occupancies/uses**  
 Compartment walls and compartment floors 9.18  
 Corridors 4.24  
 Division of storeys 4.15, 4.16  
 Interpretation of purpose groups Appendix D(3)–(5)  
 Openings in compartment walls 9.32
- Separation**  
 See Fire separation; Space separation
- Separation distances**  
 Buildings with sprinkler systems 14.17  
 Canopies 14.11, Diagram 45  
 Compartment size 14.3  
 Roofs 15.5, Table 17  
 Unprotected areas which may be disregarded Diagram 44
- Services**  
 Compartments 9.20  
 Penetrating cavity barriers 10.15  
 See also Air conditioning; Ducts; Pipes; Ventilation
- Shafts**  
 Fire-resisting construction for smoke outlet shafts 19.15, 19.16, Diagram 53  
 See also Firefighting shafts; Protected shafts; Smoke vents
- Sheltered housing** 0.27  
 Central alarm monitoring 1.7  
 Definition Appendix E
- Shop and commercial purpose group**  
 Automatic fire detection and alarm systems 1.33  
 Compartmentation 9.18, 9.19  
 Door fastenings on escape routes 6.12  
 Escape lighting Table 9  
 Floor space factors Table C1  
 Limitations on travel distance Table 2  
 Maximum dimensions of building or compartment Table 12  
 Minimum periods of fire resistance Table A2  
 Offices over Appendix D(4)  
 Permitted unprotected areas in small buildings or compartments Table 15  
 Purpose groups Table D1  
 Small shops  
     See Small premises  
 Space separation  
     Acceptable unprotected areas 14.16, 14.20  
 Store rooms 6.58, Appendix D(3)  
 Use of upper storey ancillary to use of ground storey
- Shopping complexes** 0.23  
 Compartmentation 9.18, 12.7  
 Firefighting shafts 18.7  
 Floor space factors Table C1  
 Internal fire spread 12.7, 12.8  
 Limitations on travel distance Table 2
- Showers**

## Index

- Smoke alarms 1.16
- Signs**
- See Exit signs; Fire safety signs
- Simultaneous evacuation**
- See Evacuation
- Single stair buildings**
- Added protection for escape stair 5.34
- Common escape route 3.21, Diagram 7, Diagram 9
- Ventilation 3.26
- Continuation of lift down to basement storey 6.44
- Escape stairs 5.5, 5.6, 5.33, 6.19
- Lift machine room location 6.45
- Travel distance in small premises Diagrams 22 and 23
- Single steps**
- Escape routes 6.21
- Single-storey buildings**
- Definition Appendix E
- Fire resistance of elements of structure 8.3, Table A2
- See also Sheltered housing
- Skating rinks**
- Floor space factors Table C1
- Skirtings**
- Definition of wall 7.2
- Slates or tiles**
- Designation of pitched roof coverings Table A5
- Fire-stopping junctions 10.14, Diagram 30
- Sleeping accommodation**
- Fire protection of lift installations 6.43
- See also Bedrooms; Dormitories
- Sleeping galleries**
- See Galleries
- Sleeving non-combustible pipes** 11.8
- Slipperiness**
- Floors of escape routes 6.27
- Stopping floors** 6.28
- See also Ramps
- Small premises**
- Enclosure of escape stairs 5.33
- Horizontal escape 4.32, 4.37, Diagram 18
- Means of escape 4.1
- Single escape stairs 5.6, Diagrams 22 and 23
- Smoke alarms**
- Definition Appendix E
- See also Automatic fire detection and alarm system
- Smoke and fumes**
- Control systems B1.ix, 0.31, 3.27, 5.21, Diagram 52
- Discounting of stairs
- Protected lobbies 5.35
- Shopping malls Table 2
- Fire spread B1.iv
- Retarding by sealing or fire-stopping 11.3
- Fire spread and lining materials B2.i
- Lift machine room fires 6.45
- Smoke leakage of fire doors at ambient temperatures Appendix B(1), Table B1
- Smoke reservoirs 6.41
- Smoke vents**
- Automatic operation 3.26, 6.49
- Basements 19.1–19.17
- Final exits clear of 6.34
- Fire-resisting construction Diagram 53
- Car park ceiling 12.5
- Fire-resisting construction for outlet shafts 19.15, 19.16, Diagram 53
- Free area Appendix C(5), Diagram C7
- Outlet terminal 19.10–19.11
- Ventilation of common escape routes 3.25–3.27
- Space separation** 14.1–14.20
- Roofs 15.5, Table 17
- Unprotected areas disregarded in assessing separation distance Diagram 44
- Spiral stairs**
- Escape routes 6.22, 6.23
- Sports grounds** 0.24
- See also Assembly and recreation purpose group
- Stability**
- B3 requirement page 106
- See also Integrity
- Stadia** 0.24
- See also Assembly and recreation purpose group
- Staff rooms**
- Floor space factors Table C1
- Staff training** 0.31
- Stage grids**
- See Galleries
- Stair lifts**
- Width of escape stairs Appendix C(4)
- Stairs**
- Escape routes B1.ix
- Accommodation ancillary to flats 3.46, 3.47
- Primary circulation routes 4.14
- Unprotected accommodation stairs 5.32
- Fire spread by upper surfaces B2.ii
- Limited combustibility materials Table A7
- See also Common stairs; Escape stairs; Firefighting stairs; Protected stairways
- Stallboard**
- Fire-resisting construction for smoke vent outlet terminal Diagram 53
- Smoke vent outlet terminal 19.11
- Standard fire tests**
- See Fire tests
- Standing spectator areas**
- Floor space factors Table C1
- Steel-framed buildings**
- Compartments 9.27
- Portal frames 13.4
- Steps (single)**
- Escape routes 6.21
- Storage and other non-residential**
- Automatic fire detection and alarm systems 1.36
- Compartmentation 9.18
- Escape lighting Table 9
- Fire service vehicle access to buildings without fire mains Table 19
- Floor space factors Table C1
- Interpretation of purpose groups Appendix D(5)
- Limitations on travel distance Table 2
- Maximum dimensions of building or compartment Table 12
- Minimum periods of fire resistance Table A2
- Purpose groups Table D1
- Small premises 4.35
- Space separation
- Acceptable unprotected areas 4.16, 14.20, Table 15
- Roofs Table 16
- Widths of escape routes Table 4
- Stores**
- Fire protection of lift installations 6.43
- Raised storage areas 8.7, 8.8
- Refuse storage 6.55
- Compartment walls 9.14
- In shops 6.58
- Storey exits** 4.1
- Access 4.13, 4.27
- Definition Appendix E
- Discounting 4.21
- Escape over flat roofs 6.35
- Exit capacity 4.21–4.23
- Storeys**
- Definition Appendix E
- Divided into different occupancies 4.16
- Divided into different uses 4.15
- Height of top storey Diagram C6
- Number Diagram C5
- Stretched-skin ceilings** 7.16
- Thermoplastic material 7.16
- Strong rooms**
- Smoke vents 19.5
- Structural frames**
- Elements of structure B3.iii
- Fire resistance 8.2
- Structural loadbearing elements**
- See Elements of structure
- Student residential accommodation**
- Automatic fire detection and alarm systems 1.8
- Stud walls**
- Cavity barriers 10.13
- See also Partitions
- Study bedrooms**
- Floor space factors Table C1
- Substrates**
- Lining to wall or ceiling Appendix A(18)
- Suppliers**
- Certification and accreditation 0.16, 1.23, 1.37
- Suspended ceilings**
- Concealed spaces exposed within space above 7.15
- Definition Appendix E
- Enclosure of corridors by
- partitions 4.25
- Fire-protecting 7.5, Table A3
- Lighting diffusers 7.10, 7.13–7.15, Appendix A(19), Table 11
- Limited combustibility materials Table A7
- Non-combustible materials Table A6
- Thermoplastic material 7.16, Appendix A(19)
- Switch room/battery room**
- Escape lighting Table 9
- T**
- Tall buildings**
- Escape stairs
- Added protection 5.34
- Width 5.15, 5.26, 5.27
- External walls 13.2
- Phased evacuation 5.26, 5.27
- Technical specification**
- Definition Appendix E
- Telephone system**
- Phased evacuation 5.29



## Index

- Tenancies**  
See Separate occupancies
- Thatched roofs** 15.9
- Theatres** 0.24  
See also Assembly and recreation purpose group
- Thermoplastic materials**  
Classification B2.v  
Definition Appendix E  
Glazing 7.11  
Lighting diffusers  
Forming part of a ceiling 7.13–7.15  
Layout restrictions Diagram 27  
Suspended ceilings 7.10, Table 11  
Performance Appendix A(17)–A(20)  
Rooflights 7.10, 7.12, 15.6, 15.7, Table 11  
Junction of compartment wall with roof 9.29  
Layout restrictions Diagram 27  
Limitations on use and boundary distance Table 17 and 18  
Suspended or stretched-skin ceiling 7.16
- Tiles**  
See Slates or tiles
- Timber structural components**  
Compartments 9.20
- Toilets**  
Escape lighting Table 9  
Exits in central core Diagram 13  
Warnings for hearing impaired people 1.34  
See also Sanitary accommodation
- TP(a)**  
Classification of performance B2.v, Appendix A(20)  
Glazing external windows 7.11  
Rooflights, limitations on use and boundary distance Table 18
- TP(b)**  
Classification of performance B2.v, Appendix A(20)  
Lighting diffusers, layout restrictions Diagram 27  
Rooflights  
Layout restrictions Diagram 27  
Limitations on use and boundary distance Table 18  
Spacing and size Diagram 47
- Transformer chambers**  
Final exits clear of openings 6.34  
See also Places of special fire hazard
- Travelators**  
See Mechanised walkways
- Travel distance** B1.v  
Definition Appendix E  
Flats 3.13, 3.20, 3.23, 3.52, Diagram 3, Diagrams 7–9, Table 1  
Horizontal escape 4.2, 4.10, Table 2  
Dead end Diagram 10  
Effect of access control measures 4.7  
Residential care homes 4.43  
Single escape routes and exits 4.5  
Small premises 4.37, Table 5  
Methods of measurement Appendix C(3)  
Vertical escape 5.32  
Small premises Diagrams 22 and 23
- Treads**  
Surfaces 6.27
- Turning circles**  
Fire service vehicle access route 17.11
- Fire service vehicle access route specification Table 20
- Turnstiles**  
Escape routes 6.18
- Turntable ladders**  
See High reach appliances
- U**
- UKAS**  
Accredited laboratories Appendix A(1)
- Uninsulated glazing**  
See Glazing
- Unprotected areas** 14.1  
Areas disregarded in assessing separation distance Diagram 44  
Boundaries 14.4  
Combustible material as external surface 14.9, Diagram 43  
Definition Appendix E Escape routes B1.viii–00.ix  
External wall 1000mm or more from relevant boundary 14.14–13.20  
Permitted unprotected areas 14.19, 14.20, Diagram 46, Table 15  
External wall of protected shaft forming stairway 14.8  
External wall within 1000mm of relevant boundary 14.13  
Fire resistance 14.7  
Large unpartitioned buildings 14.12  
Small unprotected areas 14.10, Diagram 44
- Unwired glass**  
Rooflights
- V**
- Vehicle access**  
See Fire service facilities
- Ventilation**  
Car parks 12.2–12.6, 19.17  
Escape routes for flats 3.25–3.27, Diagrams 7–9  
Lobbies 5.35  
Mechanical 6.46–6.53  
Concealed space used as a plenum 10.12  
Openings in compartment walls or floors 9.34  
Protected shafts 9.37  
Conveying gas 9.41  
Rooms containing refuse chutes or storage 6.56  
See also Smoke vents
- Ventilation ducts** 6.46–6.48  
Appliances  
Compartments 9.34, 11.16  
Car parks 12.6  
In protected shafts 9.40  
Openings in enclosure 9.42  
Protected stairways and entrance halls 3.18  
Protection of openings 11.9–11.14, 11.16
- Venues for pop concerts**  
Floor space factors Table C1  
See also Assembly and recreation purpose group
- Verges**  
Roof measurements Diagram C3
- Vertical escape**  
See Evacuation lifts; Stairs
- Vision panels**  
Doors on escape routes 6.17  
Inner rooms 4.10  
Small premises 4.36
- Voice alarm systems** 1.33, 5.29
- Voice communication systems**  
Emergency (EVC) 5.11, 5.12
- Volume of building or part**  
Measurement Diagram C2
- W**
- Waiting rooms**  
Floor space factors Table C1
- Walkways**  
See Mechanised walkways
- Wall climber**  
Fire protection of lift installations 6.41
- Walls**  
Cavity barriers in stud walls or partitions 10.13  
Cavity walls excluded Diagram 34  
In common to two buildings  
Calculating perimeter Diagram 48  
Compartmentation 9.10, 9.21  
Concealed spaces 10.10  
Elements of structure B3.iii  
Fire resistance 6.3, 8.2, 13.3  
Tests Table A1  
Inner rooms 4.10  
Linings B2.i 6.1–6.16  
Definition 7.2, 7.11  
Surfaces within the space above  
Suspended ceilings 7.15  
See also Cavity walls: Compartment walls; External walls
- Warehouses**  
See Storage and other non-residential
- Warning**  
See Fire alarm systems; Voice alarm system
- Washrooms**  
Protected shafts 9.36  
Protected stairways 5.38
- Water supplies**  
Fire hydrants 16.7, 16.8  
Automatic fire suppression system 2.7, 2.8
- Water supply pipes**
- WCs**  
See Toilets
- Weather protection**  
External escape stairs 6.25
- Wet mains**  
See Fire mains
- Wind loads**  
Elements of structure B3.iii
- Windowless accommodation**  
Escape lighting Table 9
- Windows**  
Definitions of wall and ceiling 7.2, 7.3  
Means of escape from flats 3.9, 3.11, 3.12  
Thermoplastic materials Appendix A(19)  
Glazing 7.11  
See also Rooflights
- Wiring**  
See Electrical wiring
- Wood**  
See Timber structural components
- Wood shingles** 15.9
- Workmanship**  
See Materials and workmanship
- Workplace (Health, Safety and Welfare) Regulations 1992** page 3
- Workshops**  
Floor space factors Table C1  
14

## [Publications](#)

The following documents have been approved and issued by the Welsh Ministers for the purpose of providing practical guidance with respect to the requirements of the Building Regulations 2010.

### [Approved Document A: Structure](#) Structure

### [Approved Document B \(Fire safety\) – Volume 1: Dwellinghouses](#) Volume 1: Dwellinghouses

### [Approved Document B \(Fire safety\) – Volume 2: Buildings other than dwellinghouses](#) Volume 2: Buildings other than dwellinghouses

### [Approved Document C: Site preparation and resistance to contaminants and moisture](#) Site preparation and resistance to contaminants and moisture

### [Approved Document D: Toxic substances](#) Toxic substances

### [Approved Document E: Resistance to the passage of sound](#) Resistance to the passage of sound

### [Approved Document F: Ventilation](#) Ventilation

### [Approved Document G: Sanitation, hot water safety and water efficiency](#) Sanitation, hot water safety and water efficiency

### [Approved Document H: Drainage and waste disposal](#) Drainage and waste disposal

### [Approved Document J: Combustion appliances and fuel storage systems](#) Combustion appliances and fuel storage systems

### [Approved Document K: Protection from falling collision and impact](#) Protection from falling, collision and impact

### [Approved Document L1A: Conservation of fuel and power – New dwellings](#) Conservation of fuel and power (New dwellings)

### [Approved Document L1B: Conservation of fuel and power – Existing dwellings](#) Conservation of fuel and power (Existing dwellings)

## **Publications**

### **Approved Document L2A: Conservation of fuel and power – New buildings other than dwellings**

**Conservation of fuel and power (New buildings other than dwellings)**

### **Approved Document L2B: Conservation of fuel and power – Existing buildings other than dwellings**

**Conservation of fuel and power (Existing buildings other than dwellings)**

### **Approved Document M: Access to and use of buildings**

**Access to and use of buildings**

### **Approved Document N: Glazing – safety in relation to impact, opening and cleaning**

**Glazing Safety**

### **Approved Document P: Electrical safety – Dwellings**

**Electrical safety – Dwellings**

### **Approved Document Q**

**Security**

### **Approved Document R**

**Physical infrastructure for high-speed electronic communications networks**

### **Approved Document to support regulation 7**

**Materials and workmanship**